

DESIGNS FOR A WORLD THAT WORKS FOR ALL

Solutions & Strategies for Meeting the World's Needs

Volume I



by Medard Gabel and
The Global Solutions Lab

DESIGNS

FOR A WORLD THAT WORKS

FOR ALL

Solutions & Strategies for Meeting the World's Needs

Volume I

by **Medard Gabel and**
The Global Solutions Lab

Copyright ©2021 BigPictureSmallWorld Inc.

All rights reserved

Printed in the United States of America

Seventh Edition

Designed by Mary Gabel, Gabel Graphics, Media, PA, www.gabelgraphics.com

ISBN: 9798634344188

Available at

www.designsciencelab.com

www.amazon.com

TABLE OF CONTENTS

| | |
|--|------|
| Participants in the Global Solutions Lab | vi |
| Acknowledgements | ix |
| Introduction | xii |
| Overview and Problem State | xxii |

VOLUME I

| | |
|--|-----------|
| PART I: FOOD & WATER FOR ALL | 1 |
| Context/State of the World Food System | 2 |
| Global Food System Preferred State. | 4 |
| Strategies. | 5 |
| Strategic Area I: Increasing Food | |
| Production/Decreasing Loss. | 7 |
| 1. The Giving Tree | 8 |
| 2. Sky Farms | 13 |
| 3. Seven Generations: | 16 |
| 4. Post Harvest Loss | 20 |
| 5. Moringa In Motion | 24 |
| 6. E.A.T.: Educating Aquaponic Technology | 32 |
| 7. AntEaters Inc. | 40 |
| Strategic Area II: Water Management | 45 |
| 8. Drops for Crops | 46 |
| 9. WaterWorks. | 48 |
| 10. WATER = LIFE. | 53 |
| 11. Increasing Household Water Security | 59 |
| 12. Sanitation and Waste Management in Informal Communities | 67 |
| Strategic Area III: Governance | 79 |
| 13. Subsidy Reduction. | 80 |
| 14. Land Reform | 85 |
| 15. Microfinance | 89 |
| 16. Food for Thought | 92 |
| PART II: CLEAN ENERGY FOR ALL | 93 |
| Context/State of the World Energy System | |
| Overview and Problem State. | 94 |
| Global Energy System Preferred State. | 95 |
| Global Energy Strategies | 97 |

| | |
|---|----------------|
| Strategic Area I: Local Energy Systems | 99 |
| 1. Powering the future | 101 |
| 2. Improving Cooking in the Developing World | 107 |
| 3. Electricity Rate Restructuring | 115 |
| 4. Energy-In-A-Box | 118 |
| 5. Green Energy | 120 |
| 6. Urban Energy and Public Transit | 130 |
| 7. Transition to Renewable Energy | 139 |
| 8. Airvengers. | 154 |
| Strategic Area II: Regional Energy Systems | 161 |
| 9. Rural Electrification via Small Scale Wind Power | 163 |
| 10. Tidal Power | 168 |
| Strategic Area III: Global Energy Systems. | 175 |
| 11. Market Driven Energy Strategies: Converting Conventional to Sustainable. . . | 176 |
| 12. The Global Energy Corps | 181 |
| 13. Carbon Subsidy Removal | 183 |
| 14. EmPower Book | 184 |
| 15. REST: Revamping the Energy | 185 |
| 16. Climate Change: Turbines, Filters, Trees, and Incentives. | 200 |
| PART III: SUMMARY/SYNERGY | 213 |
| Summary/Synergy | 214 |
| Appendix 1: The UN Millennium Development Goals. . | 116 |
| Appendix 2: The UN Sustainable Development Goals. . | 118 |
| About Medard Gabel | 233 |
| About GEM & Wayne Jacoby. | 233 |

VOLUME II

| | |
|---|---------------|
| PART I: EDUCATION FOR ALL FOR LIFE | 1 |
| Introduction | 2 |
| Strategies: | 9 |
| 1. SIB: School-In-A-Box | 11 |
| 2. WE CAN: World Educational Cooperative for All Nations. | 16 |
| 3. School/Community eHub | 19 |
| 4. eMobile Educational Resources | 20 |
| 5. Wi-Fi for Education | 21 |
| 6. SEED: Synergetic Educational Experience and Development | 22 |
| 7. Education For Everyone | 28 |
| 8. All Knowledge, All People, All the Time | 38 |
| 9. Elimu Sasa Hivi Project Leveraging Technology to Provide Quality, Accessible Primary Education for All | 46 |
| 10. Educator Training Connection Program | 52 |
| 11. Worldwide Education (WWE): Community Based Education—Learning Centers. | 59 |
| 12. EduShe | 69 |
| PART II: GLOBAL HEALTH FOR ALL | 79 |
| Context/State of the World Health System | 80 |
| Global Health System Preferred State | 80 |
| Strategies: | 81 |
| 1. Hooked-Up HealthHuts | 82 |
| 2. Cambodia Water Network: Bringing Cambodia Clean Water | 86 |
| 3. Eradication of Malaria: | 90 |
| 4. The World Healthcare Program | 93 |
| 5. The Well-Beings Program for Mental Healthcare | 99 |
| HEALTH FOR ALL for life Recap. | 107 |

| | |
|---|----------------|
| PART III: FAIR ECONOMIC SYSTEMS/PARTICIPATORY | |
| GOVERNANCE/SUSTAINABLE LIFE FOR ALL | 109 |
| Strategies: | 111 |
| 1. Living Wage For All Humanity | 112 |
| 2. United Nations Empowered. | 118 |
| 3. Investing in Opportunities | 124 |
| 4. Accounting for the Real World | 127 |
| 5. Project Tires On Foot | 135 |
| 6. Rebuilding the Lives of Refugees | 140 |
| 7. Fast Tracking Poverty Eradication Murutunguru Village, Tanzania | 146 |
| 8. Earth Dashboard: Real Time Monitoring of Key Indicators of Global Problems and Well Being. | 153 |
| 9. WorldGame: Global Problem Solving Strategic Planning Tools | 156 |
| 10. Surpassing the Digital Divide | 159 |
| 11. uVote: Mobile Technology for Civic Participation | 171 |
| 12. commUNITY | 179 |
| 13. E-LAW | 184 |
| 14. The Bridge to Prosperity: Poverty Solutions . | 190 |
| PART IV: SUSTAINABLE CITIES FOR ALL | 199 |
| Strategies: | 201 |
| 1. Where in the WORLD is our Sustainable Capital? | 202 |
| 2. Urban ReGeneration | 213 |
| 3. unSlumming: Transforming Slums Into “Young Cities” | 219 |
| 4. Sustainable Food Systems for Sustainable Cities | 224 |
| PART V: HUMAN RIGHTS FOR ALL | 243 |
| Strategies: | 245 |
| 1. Human Trafficking: | 246 |

| | |
|---|-----|
| 2. I Am Human | 254 |
| 3. Combating Human Rights Violations: E.A.R. Smartphone and Tablet Application | 257 |
| 4. A Better Future for Women and Children: Female Empowerment | 266 |

PART VI: SUMMARY/SYNERGY 277

| | |
|---|-----|
| Summary/Synergy | 278 |
| Appendix 1: The UN Millennium Development Goals. | 280 |
| Appendix 2: The UN Sustainable Development Goals. | 282 |
| About Medard Gabel | 297 |
| About GEM & Wayne Jacoby | 297 |

VOLUME III

PART I: CLIMATE FOR ALL FOR LIFE 1

| | |
|---|----------|
| Introduction | 2 |
| Climate Overview | 2 |
| State of the World Climate | 3 |
| World Climate System Preferred State | 4 |
| Strategies: | 7 |
| 1. Climate Change: Turbines, Filters, Trees, and Incentives. | 8 |
| 2. ClimActs: Creating a Climate of Change for Climate Change | 21 |
| 3. Climate Change and Regeneration | 36 |
| 4. The ReGeneration Corps | 43 |
| 5. Citizen-Control and Climate-Action | 61 |

PART II: SUMMARY/SYNERGY 69

| | |
|---|----|
| Summary/Synergy | 70 |
| Appendix 1: The UN Millennium Development Goals. | 72 |
| Appendix 2: The UN Sustainable Development Goals. | 74 |
| About Medard Gabel | 89 |
| About GEM & Wayne Jacoby | 89 |

PARTICIPANTS IN THE GLOBAL SOLUTIONS LAB

2005

Meredith Aach, Bamini Balaji, Jeremy Bang, Milly Barolette, Jean-Baptiste Bassene, Jennifer Bodenstab, Natasha Cline-Thomas, Cara Collier, Daniel Eida, Eric Fedus, Medard Gabel, Allard van Hoorn, Jochen Hartmann, Abbe Horswill, Wayne Jacoby, Noah Brooks Katz, Jai Lakhanpal, Leah Lowthorp, Kristina Mader, Chuck Michelson, Zoë Richards, Eric Rimpel, Sidharth Shah, William Sheehan, Ilya Smirnoff, Arthur Steiner, Elizabeth Thompson, Adrian Salinas Valdez, John Yuan

2006—Global Solutions Lab

Bamini Balaji, Jeremy Bang, Jean-Baptiste Bassene, Akeem Bello, Jennifer Bodenstab, Jon Brett, Yoshimi Brett, Ross Brockwell, Melissa Callender, Fabiola Carrasco, Kasia Chmielinski, Natasha Cline-Thomas, Ben Cohen, Sergio Cordiero, Gonzague de Raulin, Douglas Diaz, Kevin Dye, Easy, Daniel Eida, Sharif Ezzart, Victoria Farmer, Eric Fedus, Medard Gabel, Alexandra Heeney, David Heeney, Florence Johnson, Erica Jain, Wayne Jacoby, Erica Kane, Zane Kripe, Gabriel Kennedy, Fiona Kinniburgh, Jai Lakhanpal, James Lual, Kristina Mader, Morgan Maher, Ryan Martin, Marty McCrea, Chuck Michelson, Alexandra Montes, Aiesha Morris, Priyanka Pandit, Xena Parsons, Lexi Quint, Elizabeth Ramaccai, Ignez Renault, Stephen Rowley, Ariel Ruvinsky, Zoë Richards, Eric Rimpel, William Sheehan, Charles Sheldon, Elizabeth Thompson, David Walczyk, Vera Zago, Gregory Zuccolotto

2006—Local Solutions Lab

Charlotte Anthony, Jeremy Bang, Paul Beaton, Neha Bhatt, Jonah Butcher, Robin Cape, Julie Clark, Nick Consoletti, Darcel Eddins, Dee Eggers, Gloria Howard Free, Joel Vann Fuller, Medard Gabel, Alan Glines, Mark Hanf, Peter Harrison, Sarah Hausman, Nancy Hodges, Cathy Holt, Kimberly Hundertmark, Reo Jones, Kim Kubicke, Janet Lowe, Patricia Major, Alex MacKay, Stephanie Monson, David McConville, Ruth Meyers, Michael Miller, Charvee Patel, George Reynolds, David Silverman, Molly Sprengelmeyer, Harris Stewart, Elizabeth Thompson, Gail Thomas, Susie Watson, Sharon Willen, Ari Zitin

2007

Zeynep Arhon, Aruna Arjunan, Brett Boye, Ross Cameron, Dale Castle, Andy Cavatorta, Natasha Cline-Thomas, Gonzague de Raulin, Elke Esmeralda Dikoume, Kyle Fedus, Dustin Feider, Theodora Filip, Angela Fuller, Medard Gabel, Eric Goldfischer, Briana Graves, Iman Griffin, Samah Hanaysha, Jim Hausman, Mael Jaffres, Brent Jones, Joshua Kauffman, Michael Khayyat, Karen Lau, Anne Loyer, Kevin Machoka, Shivani Mathur, Lucas McConnell, Susan Moore, Thomas Pang, Rafi Pelles, Veronica Peña, Ben Pullman, Alex Reiner, Zoë Richards, Alex Rinomato, Ethan Rosch, Annika Semmler, Ivan Serezhin, Razi Shawahdeh, Hyoung Suk Seo, Lexi Quint, Don Whilsmith, Pollan Wong, Rachel Wong

2008

Angela Burcham, Katherine Cali, Sabrina Cusimano, Amanda Dachille, Robert Fink, Karen Guwurriro, Medard Gabel, Emily Gleason, Lauren Horneffer, Wayne Jacoby, Dave Keefe, Sam Little, Bart Misano, Brittany Mixson, Komal Patel, Daniele Seldomridge, William Sheehan, Michael Turri, Jacqui Yalango

2009

Alexis Baranov, Rebecca Berkowitz, Sabrina Cusimano, David Fand, Medard Gabel, Saroj Humagain, Wayne Jacoby, Tyler Knowlton, Barbara Kreider, Iwanka Kultschycky, Emmanuel Laguerre, Bryce Langlotz, Tran Le, Devin Massaro, Bart Misano, Jake O'Donnell, Nathan Owens, George Pavlosky, Alfonso Rivas, Robert Steele, Anna Swarbrick, Ren Shiroma, Brandin Watson, Darlene Williams

2010

Frances Brindle, Katey Fardelmann, Sarah Ferst, Medard Gabel, Kiersten Alicia Hawes, Wayne Jacoby, Marquita James, Margaret Anne Lovallo, Kathlene McGuinness, Bart Misano, Sushil Pakhrin, Ihsan Pashley, Danielle Radacosky-Pentoney, Sarah Raimondo, Brent Ritzel, Archana Sharma, Charles Sheldon, Katherine Tohanczyn, Christina Walsh

2011

Melissa Day, Zarima Fayikova, Medard Gabel, Christine Harb, Christine Hebert, Wayne Jacoby, Hien Lam, Shelby Miner, Tri Nguyen, Uyen (ana) Nguyen, Ogheneruno ("Runo) Okiomah, Joshua Pang, Sean Powers, Donovan Preddy, Alen Saju, Michael Smith, Anna Swarbrick, Karolyn Wojtowicz, Will Wright

2012

Ayuen Ajok, Sheetal Akole, Julia I Blumberg, Medard Gabel, Nino Gagaa, Aizaz Gill, Vicki Goldsmith, Wayne Jacoby, Kellie Jingoian, Katrina Mattern, Joseph Mutumu, Denis Okema, Leszek Pochron-Frankowski, Sean Powers, Rabia Sana, Anne Schiffer, Haruko Takeuchi, Yosuke Tanabe, Eric Wu, Rachel Zanders

2013

Judith Anokwu, Tariq Ausaf, Chris Cepil, Luca Dragani, Kaycee Flore, Hillary Fronk, Medard Gabel, Tobias Gabel, Tselane Hall, Hoang Nguyen Ngoc Hieu, Wayne Jacoby, Giorgi Jashiashvili, Beka Khatiashvili, Leah Knappage, Heather McAdams, Lisa Nowinski, Nhu Phan, Sean Powers, Thayvie Sinn, Dennis Yeh

2014

Shahd Albabtain, Abdullah Alsultan, Tamar Badridze, Nikita Bhatia, Medard Gabel, April Garcia, Blaise Glowiak, Mirian Gordeziani, Ketevan Grzelidze, Wayne Jacoby, Austin Joseph, Andrew McGregor, Samir Musayev, Marta Olowaska, Matthew Omochere, Anna Sugrue, Giorgi Tchiaberashvili, Rusudan Tchitashvili, Zander Tippet, Gulnara Topchishvili, Aleksandre Turkiashvili, Roxanne Viau, Cole Whiteley, Cleous Young, Emily Yung

2015

Lea Artis, Khatia Bagaturia, Eleni Demas, Medard Gabel, Mariam Gogadze, Lauren Haynes, Erin Heald, Wayne Jacoby, Nana Kakabadze, Melanie Kamusea, Mariami Khundadze, Baia Kalmakhelidze, Teona Koshadze, Diana Levinets, Anastasia Maisuradze, Sean Powers, Mariam Saghinadze, Giwa Deborah Serki, Giorgi Shubitidze, Victoria Spera, Huan Zhang

2016

Jawaria Ali, Rahaf Alsaieri, Hanan Altukhaifi, Cynthia Brain, Emily Doris, Medard Gabel, Wayne Jacoby, Sayondee kofa-Kumorteh, Elizabeth Legesse, Milene Mbassa, James Nelson, Jon Perkins, Lea Sanders, Faustin Sebishimbo, Rachel Sheraden

2017

Maxwell Adew, Rahaf Alsaieri, Michelle Asim, Hanan Altukhaifi, Rohan Bhambhani, Medard Gabel, Wayne Jacoby, Giorgi Jashivashvili, Mariam Javakhishvili, Sara Jefry, Charles Kuvuna, Edmond Mbadu, Fatemah Peeran, Peter Reilly, Jordan Weinles

2018

Caitlin Ackerman, Maxwell Adeoy, Adel Almeiri, Quiran Banks, Julia Bond, Becky Bond, Jaylen Callier, Pascaline Coly, JaMiyah Kimber-Fitzpatrick, Eniola Folorunso, Medard Gabel, Shaiana Galbraith, Aimirria Gilbert, Crystalle Green, Abigail Hoyt, Wayne Jacoby, D'Ontay Love, Lucas Lovekin, Victor Morimoto, Edmond Mbadu, Rylisha Prymus, Beibei Qin, Jaba Saralidze, Jose Soto, Shyla Warren, Tiara Williams

2019

Faiza Arshad, Javier Carmona, Dashiell Chang, Medard Gabel, Alexander Groce, Ashley Hock, Dennis Isak, Wayne Jacoby, Fawwaz Ali Khan, Jawaria Ali Khan, Duaa Khawjah, Zogore Mouni Audrey Lade, Erin McLaughlin, Vu Duc Nhat Minh, Lyia Mujalled, Hajrad Najam, An Nguyen, Huy Nguyen, Comfort Z. Olorunsaiye, Gionna Pembroke, Gurinder Singh

2020

Mohanad Aljarboua, Sarah Allaben, Jazmine Cable, Ravi Cullop, Minh Dao, Medard Gabel, Davina George, Wayne Jacoby, Jawaria Khan, Isabelle Lee, Edmond Mbadu, Cynthia Muaka, Duong Nguyen, Nafisa Nujhat, Aza O'Leary, Khoa Pham, Amanda Ravenhill, Anita Shervington, Gurinder Singh, Jim Walker, Ellen Wilson

2021

Maxwell Adeoy, Nd Esther Aguh, Stephan Bourget, Thu Bui, Alfonso Rivas Cruces, Scott DeJong, Engels Diaz, Sebastian Fernandez, Medard Gabel, Huong Hoang, Wayne Jacoby, Jawaria Ali Khan, Hamza Kiyani, Sophia Lee, Ashaq Malik, Carrington Mattis, William Meyerhoff, Cynthia Muaka, Rebecca Muller, Nafisa Nujhat, Anika Rahman, Emily Saunders, Imaad Uzun, Martha Minnie Afuma Waindim, Jim Walker, Aurora Wiley

Lab Directors/Producers

| | |
|-----------|---|
| 2021 | Lab directed by EarthGame and BigPictureSmallWorld in cooperation with Global Education Motivators |
| 2020 | Lab directed by BigPictureSmallWorld in cooperation with Global Education Motivators and EarthGame. |
| 2013-2019 | Lab directed by BigPictureSmallWorld in cooperation with Global Education Motivators, EarthGame, and Pacem in Terris. |
| 2005–2012 | Labs directed by BigPictureSmallWorld in cooperation with Global Education Motivators. |
| 2005–2007 | Labs produced by Buckminster Fuller Institute and directed by BigPictureSmallWorld in cooperation with Global Education Motivators. |

ACKNOWLEDGEMENTS

The *Global Solutions Lab* would like to acknowledge and thank the following people at the United Nations and elsewhere for their much-appreciated and many-faceted support:

- Kathleen Abdalla**, UN Department of Economic and Social Affairs (DESA)
- Dr. Richard Alderslade**, World Health Organization (WHO)/Senior External Relations Officer, Health Policy
- Prateek Awasthi**, UN Population Fund (UNFPA)
- Mandeep Bains**, UN Millennium Campaign/Senior Policy Advisor
- Bernhard Barth**, UN-Habitat, Topic: UN-Habitat's Climate Action for Cities Campaign, Japan
- Nazim Benchikh**, UNFPA/Youth Program Fellow
- Vivian Bernstein**, UN Academic Impact
- Afton Beutler**, Global Education Opportunities
- Suzanne Bilello**, UN Education, Science and Culture Organization
- Wynne Boelt**, UN Department of Public Information (UNDPI)
- Jo Bourne**, UNICEF Education
- Marcia Brewster**, DESA, Sustainable Development Division
- Juan Carlos**, Chief NGO Section
- Margaret Carrington**, UN Food and Agriculture Organization (UNFAO), World Food Programme (WFP)
- Florence Chenowith**, UNFAO
- Daren Cheatham**, UN Office of Secretary General
- Albert Cho**, UN Development Programme (UNDP)
- Elisabeth Clemens**, UNDP
- Nadine Clopton**, Co-Chair, Youth & Intergenerational Sub-committee, Global NGO Executive Committee
- La Neice Collins**, UN Academic Impact Secretariat
- Elena Crete**, Project Manager, America's Zero Carbon Action Plan, UN Sustainable Development Solutions Network
- Ramu Damodaran**, Chief, UN Academic Impact Secretariat, NY
- Swati Dave**, UN Visitor's Services
- Francesca De Ferrari**, UN Human Settlements Programme (UN-Habitat)
- Ilaria DiMatteo**, DESA/Chief, Energy Statistics Section
- Yamina Djacta**, UN-Habitat/Deputy Director
- Hasan Ferdous**, UNDP
- Arunabha Ghosh**, UNDP, UN Human Development Report
- Maria Godunova**, DESA/Sustainable Development Officer
- Hal Goldstein**, Start-up Investor
- Angel Gomez**, UN-Habitat/NY Office
- Shamina de Gonzaga**, Office of the President of the United Nations General Assembly
- Donna Goodman**, UNICEF, Water, Environment and Sanitation Section/Program Advisor
- Ellen Gustafson**, UNFAO, WFP
- Patrick Haverman**, UNDP/Project Manager Millennium Village, Regional Bureau for Africa
- Patrick Hayford**, UNDP/Director, Office of the Special Adviser on Africa
- Liz Hallett**, UNWFP
- Thiago Hérick de Sá**, World Health Organization, Geneva
- Stephanie Hodge**, UNICEF

- Wayne Jacoby**, Global Education Motivators
- Bashir Jama**, UNDP, Millennium Villages Project
- Tarik Jasarevic**, WHO **Justin Karr**, UBS Investment Bank
- Saba Kalam**, National Programme Manager, UNDP, India
- Kefilwe Koogotsitse**, UNFPA/ Youth Program Fellow
- Karoly Kovacs**, DESA/Environment, Energy and Industrial Statistics
- Jakob Krupka**, UN-Habitat
- Charles Kuvuna**, CEO, Kuvuna Foundation
- Jorge Laguna-Celis**, UN Environment Program (UNEP)
- Julie Larsen**, DESA, Program on Youth
- Jennifer Longo**, UN, Visitor's Services
- Bettina Luescher**, UNWFP/ Spokesperson
- Changu Mannathoko**, UNICEF, Education Section
- Cecilia Martínez**, UN-Habitat, NY Office/Director
- David McCreery**, UNAI
- Mathew Mcilvenna**, UNWFP
- Curt McNamara**, MCAD, Systems engineer
- Hannah Messenger**, UN SDG Action Campaign, UK
- Dr. Sheldon Miller**, Climate Change, Professor, Chestnut Hill College
- Stephanie Miller**, Woodcock Foundation/Grants Director
- Lisa Mitchell**, Strategic Planner, Burlington
- Pragati Pascale**, UNDP
- Giorgia Passarelli**, Office of the United Nations High Commissioner for Human Rights (OHCHR)
- Gonzalo Pizarro**, UNDP/Policy Specialist on Water Resources
- Daniel Platz**, DESA
- Nat Quansah**, Academic Director, School for International Training, Madagascar
- Stephanie Rambler**, DESA/ Sustainable Development Officer
- Arturo Requesens**, Secretariat of the United Nations Permanent Forum on Indigenous Issues, Division for Social Policy and Development
- Mary Roodkowsky**, UNICEF/Special Advisor for United Nations Affairs
- Renata Rubian**, UNDP Bureau of Development Policy/Policy Specialist, Poverty Practice
- Nouhoum Sangarey**, OHCHR
- Guido Schmidt-Taub**, UN Sustainable Development Solutions Network/Executive Director
- Vanessa Tobin**, United Nations Children's Fund
- Nouhoum Sangarey**, OHCHR
- Cynthia Scharf**, UNOSG
- Broddi Sigurdarson**, DESA
- Jim Sniffen**, UNEP/Programme Officer
- Friedrich Soltau**, DESA
- Leonardo Souza**, DESA
- Friedrich Soltau**, DESA
- Emma Torres**, VP of the Americas & Head of New York Office, UN Sustainable Development Solutions Network
- Dorine Van Der Wal**, World Health Organization, Geneva
- Sergio Vieira**, DESA, Social Perspective Development Branch
- Jim Walker**, EarthGame
- Lucy Wanjiru**, UNDP Gender Team
- Carol Welch**, UNDP/US Coordinator, Millennium Development Goals Campaign

Steve Wiley, Corporate Executive
Gregory Woodsworth, UNDP
Bill Yotive, UNDPI

United Nations International School

Jean-Baptiste Bassene

Dr. Lidana Jalilyand

Abraham Muslin

Dr. Radha Rajan

Teaching Assistants: Daniel Eida,
Michael Khayyat, Zoë Richards
and Natasha Cline-Thomas

UNIS Administration, Staff, and
Students

Chestnut Hill College

Don Visher

Dr. Wolfgang Natter VP for
Academic Affairs/Dean of
Faculty

Woodcock Foundation

Steven Liebowitz

Stephanie Miller

HSBC Securities

Raphael Dumas

Smithsonian Cooper- Hewit National Design Museum

Cynthia Smith

Buckminster Fuller Institute

Josh Arnow

Matt Baring

Faith Flanigan

Jochen Hartmann

Angela Molenaar

Amanda Joy Ravenhill

Elizabeth Thompson

Kallie Weinkle

Cadient Group

Jim Walker

UBS Financial Services

Christian Patino

INTRODUCTION

Global Solutions Lab*

What you are about to read is the product of many young people from around the world.

This book represents the work of hundreds of young people from five continents and 40 countries. They came together each summer and worked extraordinarily hard on understanding what the most pressing problems facing their world are, and even harder at designing solutions

Design science is the organized use of imagination and science to develop innovative and viable solutions to critical real-world problems.

and strategies for eliminating these problems.

This book was developed over a period of 16 years (2005–2020). It would not exist if not for some extraordinary people at the United Nations who provided their input, guidance and feedback along the

way. These people took time out of their busy schedules and provided not only the guidance but also the inspiration that was needed to complete our tasks. They are listed above in the Acknowledgements.

The youth who participated in the programs that produced this book were part of the *Global Solutions Lab*. These Labs are ongoing and take place each June. Other *Global Solutions Labs* take place during the school year. The *Global Solutions Lab* is a workshop where the tools of design science are used by groups to collaboratively develop creative solutions to global and local problems, and strategies for the implementation of those solutions.

These particular Labs are focused on developing solutions and strategies for reaching the UN's Sustainable Development Goals¹ and were held each summer between 2005 and 2020. Each year's Lab focuses on a specific topic, such as poverty, food, energy, health care, education, climate change or environmental sustainability.

These *Global Solutions Labs* have taken place in New York at the UN and the UN International School, in Philadelphia at Chestnut Hill College and at the University of North Carolina in Asheville. They are put on by three organizations—BigPictureSmallWorld, Global

*Note: Originally called the Design Science Lab, the name became Design Science: Global Solutions Lab from 2010–2014. It was changed to Global Solutions Lab in 2015. Throughout this book, the name has been changed to Global Solutions Lab for consistency.

Education Motivators, and EarthGame.²

The goals of the Lab included:

- Develop strategies for meeting the basic human needs of everyone in the world
- Learning about the Sustainable Development Goals, their usefulness to the world, and how we can use them to make the world a better place
- Developing viable strategies for achieving one or more Sustainable Development Goals
- Develop strategies for meeting the basic human needs of everyone in the world
- Learning design science and how to apply it to global and local problems
- Increasing our understanding of global dynamics, world resources, human trends and needs, and options for humanity's success
- Increasing the public's understanding of these issues through disseminating the strategies as widely as possible
- Serving as an incubator and growing force for developing and disseminating design science techniques for complex problem solving and development of viable solutions to the worlds problems
- Learning a methodology for changing the world.

Attending the Labs are groups of college and high school students and professionals ranging in age from 16 to 55 with the average age of 22. Labs run for one to two very intense weeks, where participants learn and apply the concepts and tools of design science as they develop their strategies to achieve the Sustainable Development Goals (SDGs). The participants are briefed by UN staff from the UNEP, UNDP, UNICEF,

The work of the Global Solutions Labs are focused on demonstrating how, using present day technology, known resources, and limited financial wherewithal global and local problems can be solved in sustainable and affordable ways. The overall strategies developed by the participants of the Lab, as will be seen in this book, are more than the sum of their parts. Together, they describe a world where the basic human needs of all of humanity are met, the Earth's environmental life support systems are allowed to regenerate, and the world is safe and secure from war and crime.

WHO and others on the SDGs, their context, history, measurement, the progress made so far, and strategies in use for reaching them. An introduction to design science, *Design Science Primer*, is then provided. Lab participants typically work ten to twelve hours a day on developing their solutions. On the last day of the Lab, participants go to the UN where they conclude the Lab with a presentation of their work to, and feedback from, UN staff, as well as corporate and foundation executives. An overview of this work is what is presented in this book.

The ideas and words describing the strategies are those of the Lab's participants. I (Medard Gabel) edited for consistency and filled in a few spots here and there where appropriate. Each chapter is different and reflects the team or individual that developed it, as well as the nature of the problem or issue being addressed.

Designs for changing the world— Design Science

Design Science is a methodology for changing the world. It involves the application of the principles and latest findings of science to the creative design and implementation of solutions to the problems of society. It is a way of recognizing, defining, and solving complex problems that is based on innovation and thrives on transparency. It takes a whole systems, global, anticipatory and regenerative approach that fosters creative collaboration and synergy in the development of comprehensive solutions to both global and local problems.

Unlike many planning and political processes that compartmentalize issues and seek to develop solutions in a vacuum, Design Science stresses comprehensive thinking based on a clear understanding of the state of the world, available resources, appropriate technology, culture, environmental constraints, and the interconnections between world problems and opportunities. The Design Science planning process provides a framework for devising solutions to current problems as well as anticipating future needs.

Design Science is also different from other problem solving and planning methodologies in its comprehensive, anticipatory, inclusive, and transparent approaches to the development of solutions. It takes a “whole to particular” approach that is both global in perspective and in its examination of options. It seeks to build capacity rather than merely

solve problems, and to develop solutions that are transformative rather than merely the reforming of already inadequate systems. It is informed by a moral vision that places a priority on designing ways of meeting unmet basic human needs in ways that are environmentally sustainable and socially just.

The core of this approach to problem solving and planning is both a concern with whole systems—the whole Earth, the entire history of the

If a problem can't be solved as it is, enlarge it.

—Dwight Eisenhower

planet, the global economy, all of technology, and all of humanity, both those living now and those yet to be born—as well as a recognition that everything is implemented locally, and that the “whole” is merely the context for the local. Design science has both a global perspective and a local focus. It recognizes that it is the local upon which the success or failure of a particular design solution will thrive or die.

Design Science is *comprehensive*, in that it starts from the whole system and works back to the special case. It deals with all facets of a problem including the larger system of which the problem is a part; in this sense, design science seeks to build capacity, not just solve problems. It is *anticipatory*, in that it seeks to recognize the threats coming down the pike before they arrive full blown on an unsuspecting or ill-prepared society; and it deals with the way things are going to be when the solution is going to be implemented, not just the way things are in the present. It is a *design* strategy, in contradistinction to a political or ‘let’s pass-a-law-and-change-human-behavior’ approach; it seeks to change the larger system of which the specific problem is a part through the introduction of innovative artifacts or policies.

This “comprehensive anticipatory design science” is at least as much a perspective on the problems of the world as it is a methodology for tackling those problems. When applied to contemporary problems, it can lead to strikingly fresh insights and solutions.

Design science is a tool that is based on a global perspective and a systems approach to the problems of the world. It assumes that globalization has made the world an ever more interconnected whole, and any successful problem solving of society’s systemic ills needs to be an approach that is global, comprehensive, visionary, and based on science, not politics, ideology, or wishful thinking. The entire world is now the relevant unit of analysis, not the city, state, or nation. We are

onboard, as Buckminster Fuller pointed out, “Spaceship Earth,” and the illogic of 200+ nation state admirals all trying to steer the spaceship

We need to focus on creating wealth, not just reducing poverty. Development, not growth is our goal; we need to transform society, not just enlarge it.

in different directions is made clear through this metaphor—as well in Fuller’s more caustic assessment of nation states tending to act as “blood clots” in the world’s global metabolism.

The design science process is augmented by vast quantities of statistical information about the state of the world, its resources, human trends, needs, and technology. With the advent of personal computers and the Internet this information became almost universally available—and with it, design science found its perfect complement. Coupled with the tools of the information age, design science gains the power to reach its potential. The Internet has not leveled the global playing field so much as expanded it, and the good-ol’-boy-status-quo-maintaining political process can now be subverted by a process that brings Thomas Jefferson into the twenty-first century.

In Fuller’s words, design science is a process where individuals or teams of people can “make the world work, for 100% of humanity, in the shortest possible time, through spontaneous cooperation, without ecological offense or the disadvantage of anyone.”

Making the world work for 100% of humanity reflects Fuller’s global perspective as well as his values. We are not here just to make ourselves rich, famous, or top consumer of the day or decade, or here just for the 5% living in our part of the world; we are here for all humanity. The “spontaneous cooperation” is instructive in light of the previous discussion. The phrase does not read, “make the world work for 100% of humanity through a central government, or through enforced coercion by a strong military” but through cooperation that arises from a fundamental transparency of society and its needs. If everyone knows what the situation is, has a clear vision of what should be and what needs to be done, we cooperate to get it done—as we do as a society in times of emergency.

Fuller said:

I am enthusiastic over humanity's extraordinary and sometimes very timely ingenuities. If you are in a shipwreck and all the boats are gone, a piano top buoyant enough to keep you afloat that comes along makes a fortuitous life preserver. But this is not to say that the best way to design a life preserver is in the form of a piano top. I think that we are clinging to a great many piano tops in accepting yesterday's fortuitous contrivings as constituting the only means for solving a given problem.

Design science is a method for developing the life preserving and enhancing solutions to society's problems.

The *Global Solutions Lab* uses the principles and methodology of design science and applies them to developing comprehensive strategies for the solution of global problems, primarily under the aegis of the United Nation's Sustainable Development Goals. The Design

Science/Local Solutions Lab takes an identical approach but the focus is on solutions that are to be locally implemented.

In summary, design science is a problem solving and strategic design and planning process based on the following "big picture" assumptions and design protocols:³

- *Wholeworld*—The whole world is now the relevant unit of problem solving; problems need to be seen from a global perspective.
- *Long-term*—The long term is the framework in which we must operate; given this perspective, prevention, rather than treatment or cure, is the logical and most economical option.

**A map of the world
which doesn't include
Utopia isn't even worth
glancing at.**

—Oscar Wilde

**You can no longer save your family,
tribe or nation. You can only save the
whole world.**

—Margaret Mead

- *Think Comprehensively*—Framing problems in their widest possible context helps see upstream interconnections and causative factors that can impact downstream problems and options.
- *Everybody wins*—Solutions with winners and losers are not sustainable.
- *Transparency* is key; solutions that don't make their assumptions and true costs and impacts visible to everyone are not sustainable.
- *Capacity, not problems*, is the focus; we need to see “problems” not as something that needs to be “solved,” but as a symptom of something larger—the need to enlarge the capacity of a system; we need to focus on creating wealth, not just reducing poverty.
- *Needs as markets*—the world's needs are real or potential markets; problems are unmet needs that can often be met through creative products matched to the real needs of real people; poverty is a mandate for design and entrepreneurial innovation and creativity, not just government intervention and paternalistic imposition of top down “solutions.”
- *Design replaces politics*; design sees what is needed, not what is just expedient or politically easy, and figures out how to make it happen; design starts with a vision of what is needed, not what is popular; it seeks to find or design an artifact that solves a problem or builds the capacity of a system in such a way that the source of the problem is eliminated.
- *More with less* is the design ethic; getting ever-higher performance out of every gram of material and erg of energy invested in every function performed by our human-made life-support is critical to making the world's limited resources meet the needs of our growing population and to reducing our impact on our environment.
- *Biology replaces mechanics*; viewing the world as a living system fosters a respect for a problem's complexity, an awareness of the context or environment in which it is embedded, and the possible solutions that can result in strengthening the health of the system and the elimination of the problem.
- *Development, not growth* is our goal; we need to transform society, not just enlarge it.
- *Respect Gestation Rates*—everything has its own gestation rate, and working with these is essential, whether it is the growth and development of a technological option or societal change.

The fundamental difference between creating and problem solving is simple. In problem solving we seek to make something we do not like go away. In creating, we seek to make what we truly care about exist.

—Peter Senge

- *Scalability* is essential; if a solution to a problem, or a product or service for a market cannot be scaled up from the prototype stage to wide spread adoption and use, it is still born.
- *Look for the trim-tab*—Small and strategically placed interventions can cause large-scale and profound change; find the design leverage points where a small amount of change can bring about large impacts.
- *Preferred state planning*—what we want and where we want to be in ten years is more important than what the problem is right now; the vision of the ideal is more important and powerful than reacting to what is thought possible given current limitations; perspective adds opportunity, vision drives action; resources follow vision. The design science process begins with a vision

SUSTAINABLE DEVELOPMENT GOALS



statement of where we *want* the world to be. This vision of the preferred future is based on and informed by an ethical view of what should be, and then transformed through comprehensive design into an economically compelling solution.

Global Preferred State

Strategies for achieving the Sustainable Development Goals and Preferred State

As listed in the above assumptions and protocols, the Design Science problem solving process begins with a vision of how the world should be. This vision is usually specific to the general issue or problem being addressed, such as poverty, food and hunger, energy supply, education and the like. It is often helpful though to begin the design process with a broader preferred state for the whole world that encompasses the well being of all the world's life support systems. The following is such a global preferred state:

All of humanity—every child, woman, and man in every country in the world—has, on a sustainable basis,

- Abundant supplies of nutritious and culturally appropriate food.
- Adequate housing complete with sanitation facilities and clean running water.
- Abundant supplies of energy that are clean, safe, and affordable.
- Access to local comprehensive health care and the latest advances of medical science.
- Access to education, so that literacy is universal, as are opportunities for advanced (college level) education; access to the Internet is universal.
- Access to communication and transportation facilities that are readily available and affordable, so that anyone can communicate with anyone else on Earth who wants to be communicated with, and people can travel anywhere they want to go.
- Access to employment opportunities and fulfilling work—including vocational alternatives, re-training, and on-the-job-training—are available to all.

-
- Access to open borders, free of trade and emigration restrictions, subsidies, and other barriers to market-driven economies.
 - Access to information so that all public negotiations (for example, labor contracts, legislation, and government contracts), accounting practices, and elections are transparent and open to inspection by anyone at anytime.
 - Access to decision making, so that all citizens have a significant role in decision-making processes that affect their lives, and each lives in a peaceful, democratic, secure and safe world that is free from crime, terror, and nuclear, chemical, and biological weapons.
 - Access to a clean, healthy environment that is free of toxic wastes, pollution of all kinds, soil erosion, and damaging industrial and agricultural practices.
 - The biosphere and its resources are self-regenerating, with humans cooperating to ensure this.
 - Biodiversity is increasing throughout the world.
 - Around the globe, strong social incentives foster democracy personal initiative, trust, cooperation, respect, and love—and discourage all forms of torture, degrading treatment, and punishment.
 - Access to an independent and impartial tribunal to which each person is entitled, on an equal basis; each person has the right to nationality and to perform public service in one's own country.
 - Access to rest and leisure.
 - Access to special protection, care, and assistance for mothers and children.
 - Freedoms of speech, of the press, and of religion are the rule everywhere.
 - All forms of prejudice—against another's ethnicity, race, religion, origins, gender, age, sexual preference, or income level—are gone.
 - Every culture and nation respects and celebrates the unique value of all others, and provides strong social supports for individuals, families, and communities.
 - The arts in all forms are widely appreciated and cultivated.
 - Spiritual growth and fulfillment is the norm for all humans.⁴

OVERVIEW AND PROBLEM STATE

Context/World Systems

In a very real sense the state of the world today is the preceding Preferred State with a negative qualifier attached. That is, all of humanity does *not* have “abundant supplies of nutritious and culturally appropriate food and clean water”; they do not “live in more than adequate housing complete with sanitation facilities and clean running water,” etc.

In addition, and more specifically, the world today is characterized by⁵:

- 1 billion people are not adequately nourished or face the specter of hunger
- 884 million do not have access to clean water
- 1.6 billion people are without access to adequate sanitation
- 2 billion people are inadequately housed; 600 million live in urban slums
- 100 million people are homeless
- 800 million to 2.5 billion people have no access to essential health services
- 10 million children under 5 die from easily preventable causes each year
- 42 million people who die from curable infectious and parasitic diseases each year
- 40 million people are infected with the AIDS virus
- 300 million people seek treatment for malaria each year
- 2 billion people are infected with tuberculosis
- 900 million adults are illiterate
- 100 million children are not in primary school
- 1 billion people are without access to electricity
- 3 billion people are without access to adequate supplies of energy
- 1.2 billion people live on \$1.00 per day or less
- 2.8 billion people live on less than \$2.00 per day
- 40 million children are laborers
- 50 million people are refugees or displaced
- 7 million tons of carbon are added to atmosphere each year

- 2.5 billion tons of topsoil are eroded from world croplands per year
- 6 million acres of desert land are formed annually by mismanagement
- 15 million acres of forest are destroyed each year

Endnotes

- 1 For more information on the Sustainable Development Goals, see <https://www.un.org/sustainabledevelopment/sustainable-development-goals/>
- 2 The 2005–2007 Labs were also put on in cooperation with the Buckminster Fuller Institute. For more information on these organizations, see: <http://www.bigpicturesmallworld.com>; <http://www.gem-ngo.org/> and <http://www.bfi.org>
- 3 *Regenerative Development* <http://www.designsciencelab.com/resources>
- 4 The description of the future was synthesized over a twenty-year period from over one thousand groups of anywhere from 30 to 250 people each in size. Each group answered the question: *What do you want the world to look like in twenty-years?* Adding the members of all the groups together resulted in over 200,000 people combining their collective expertise to answering that question.
- 5 For footnotes on each of the numbers, see: http://www.bigpicturesmallworld.com/war-peace/context_chap1.shtml



PART I

**FOOD &
WATER
FOR ALL**

Context/State of the World Food System

The work done by the Global Solutions Lab is embedded in a context of the global conditions surrounding the world's population and the global food system that supplies that population with its food. The following basic facts lay out this context:

- World population in 2020: *7.5 billion*.
- Over 50% of the world's total population—almost 4 billion people—are living in urban areas.
- Number of well nourished people in the world: *6.7 billion people*.
- Number of hungry or malnourished people in 2020: *820 million*.
- Hunger and malnutrition are killing over three million children each year—a figure that roughly equals the entire pre-school population of a large country such as Japan.¹ Many of these children die from a handful of treatable infectious diseases including diarrhea, pneumonia, malaria and measles. They would survive if their bodies and immune systems had not been weakened by hunger and malnutrition.
- People living in rural areas constitute nearly 80% of the 820 million hungry people in the world, and over 50% of these are small, subsistence farmers.²

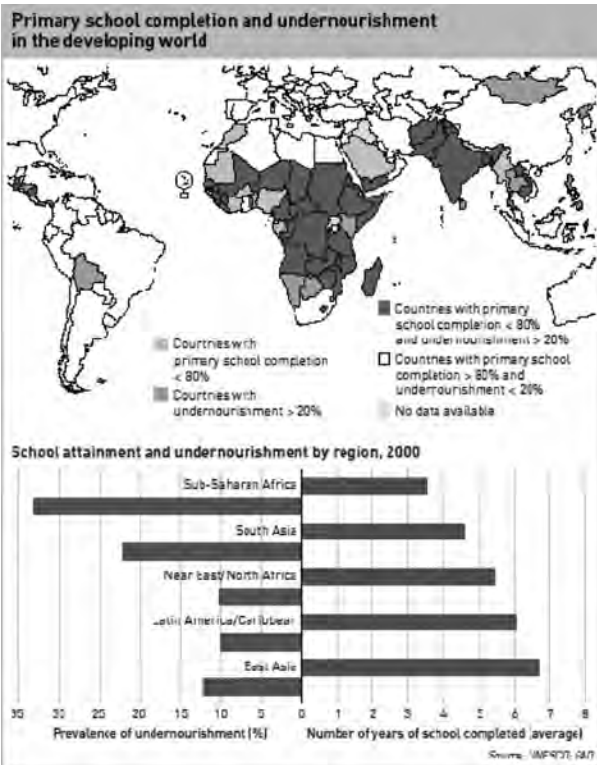

- Percent of hungry or malnourished people in 2020: *11%*.
- Percent of hungry or malnourished people in 1970: *24%*.
- 2.7 billion people were *added* to the world's population in this same 40-year period. This reduction, and the continuing yearly removal of 5 to 8 million additional people from the rolls of the malnourished,³ is one of humanity's greater accomplishments.
- At the rate we are "improving" it will take 100 to 163 years to eradicate hunger from the world.

- Water resources play a critical role in the global food system. Not only is water essential for human survival, it is needed for producing crops. Irrigated farmland, which accounts for less than 20% of global food production land, produces 40% of all food.⁷⁴ Irrigation increases yields of most crops by 100 to 400%.⁵
- There are close to 1 billion people in the world without access to clean water and 1.6 billion without access to sanitation.⁶
- Fertilizer plays a key role in global food production. Without adequate fertilizer, total food production would not be enough to feed the world.
- Lack of education and undernourishment are linked.
- The global economic system and social/political arrangements play at least as big a role in the global distribution of food and hunger as does the weather. Subsidies given to wealthy country's farmers to encourage their production has serious and deleterious impacts on the farmers in the poorer parts of the world.
- Low-income food producers' lack of access to credit keeps these populations from moving up the economic ladder.
- Having a clear vision of how things should be is essential for getting there. Having specific and measurable goals for the global food system is critical for making those goals real.

All charts on these two pages and the next are from *The State of Food Insecurity in the World, Food and Agriculture Organization of the UN annual hunger report*.

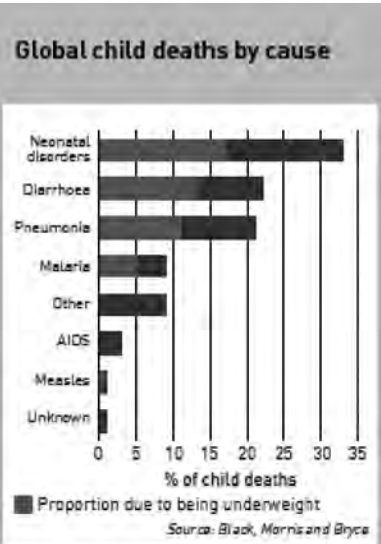
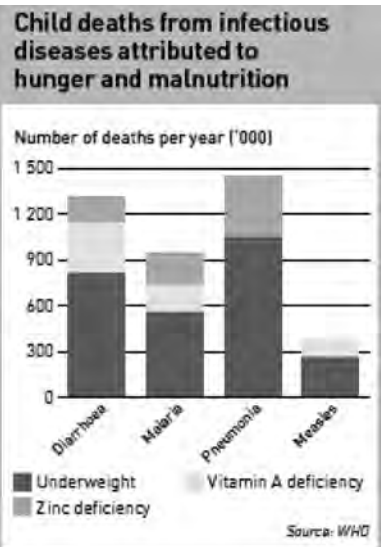
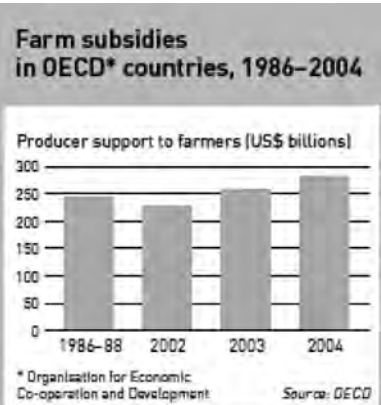

Global Food System Preferred State

The Global Solutions Lab's *Global Food System Preferred State* was developed from the values and vision of the Lab's participants. It is not a prediction of what we thought the world would look like, but what we wanted it to be. It is a statement of values as well as definition of success and how a healthy food system should be functioning. It was what we thought morally justified, economically desirable and politically tenable.

The *Global Food System Preferred State* is one that incorporates the following aspects:

By 2030:

- 100% of humanity is well nourished with abundant, safe, affordable, and sustainable food supplies
- Food production is done in environmentally regenerate ways
- There is an ever increasing diversity of food choices and biological resources
- There is an ever increasing resource efficient food system that is knowledge, rather than energy intensive.
- There is ever increasing local self-reliance in the production of food and a corresponding global interdependence of our local food system and supplies.
- National and local food systems are subsidy free, open market, and fair trade based.
- There are emergency backup systems and anticipatory crisis management systems in place.
- Local and global food systems are adaptable, flexible, and transparent.
- Local and global food systems are conflict free; food is never used as a weapon or bargaining chip.
- The global commons are managed for global well being, not national, local, or individual gain.

The strategies that follow this section were designed to achieve the SDG #2 by 2030.

STRATEGIES

for achieving the UN Sustainable Development Goal #2 by 2030:

Eradicate Extreme Poverty and Hunger

Eliminating hunger from the world, reaching the UN's Sustainable Development Goal for food by 2030, and attaining the Global Food System Preferred State from the previous page is a multi-dimensional and interrelated set of problems. Here are some of the broad brush-stroke actions needed:

To eliminate hunger, improve nutrition, and guarantee incomes for people who cannot afford basic food, food systems need to switch to regenerative farming practices and investments are needed for:

- eliminating hunger, including responses to emergencies and safety nets for food short areas
- improving nutrition
- meeting the special needs of smallholder farmers or artisanal fishermen
- reducing post-harvest losses
- maintaining and restoring productive soils
- improving rural infrastructure
- increasing the productivity and sustainability of commercial agriculture
- eliminating of agricultural export subsidies
- reducing greenhouse gas emissions from agriculture
- increasing the resilience of agriculture to climate change
- increasing research and development for agriculture and food security.

The following pages outline Global Solutions Lab strategies for in the areas of food production, water management and food system governance, which adequately funded and implemented at scale, are intended to reach Lab's Food System Preferred State and the UN's Sustainable Development Goal #2.

Strategies for achieving the Global Solutions Lab Preferred State by 2030:

Eradicate Hunger

- Reduce to zero, between 2015 and 2030, the number of people who suffer from hunger.

Endnotes

- 1 *The State of Food Insecurity in the World*, Food and Agriculture Organization of the UN annual hunger report, November 2005.
- 2 Elizabeth Becker, “Number of Hungry Rising, UN Report Says” *New York Times*, 12-8-04
- 3 “Stop blaming the weather,” (*The Economist*, June 10, 2002, p.13); Hunger strikes,” (*The Economist*, October 21, 2001, p. 76); “Food shortages,” (*The Economist*, October 28, 2000, p. 102)
- 4 UN FAO, AQUASTAT <http://www.fao.org/waicent/faoinfo/agricult/agl/aglw/aquastatweb/main/html/background.htm>
- 5 FAO, *Water and Food Security* (Rome, Food and Agriculture Organization of the UN, 2002) www.fao.org
- 6 Ibid



**STRATEGIC AREA I:
INCREASING FOOD
PRODUCTION /
DECREASING LOSS**

- 1. The Giving Tree**
- 2. Sky Farms: Urban Food Production**
- 3. Seven Generations: Regenerative Agriculture/
Integrated Cropping Systems**
- 4. Post Harvest Loss: Cool Pot and Grain Gain**
- 5. Moringa in Motion**
- 6. E.A.T.: Educating Aquaponic Technology**
- 7. AntEaters**

1. THE GIVING TREE

By Cara Collier, Leah Lowthorp, Chuck Michelson

Strategic Summary: *Increase food production, income, and employment in food short areas of the world by increasing fertilizer use through fast growing, nitrogen fixing trees. Simultaneously reduce atmospheric carbon thereby helping reduce global climate change. Finance through carbon abatement credits.*

Introduction

People living in rural areas constitute nearly 80% of the 1 billion hungry people in the world, and over 50% of these are small, subsistence farmers.¹ Limiting factors for food access and production for these people include deforestation, centralized monoculture, poor soil quality, and restrictive factors for cultivation (i.e. fertilizer costs). *The Giving Tree Program* proposes a creative strategy in agroforestry centered on an amazing tree that gives and keeps on giving.

Leucaena: The Tree that Keeps on Giving

The leucaena tree (*leucaena leucocephala*) represents an enormous opportunity for doing more with less, and an amazing resource for reducing world hunger. It is highly adaptive, able to grow in both tropical and arid climates, and is highly drought-resistant. It is one of the fastest growing trees on the planet (10–12 ft/yr),² and is thus able to be harvested annually for its wood. It is a prodigious nitrogen fixer—more than 100 to 200 kg of nitrogen (or 500–1000 kg ammonium sulfate) per hectare is fixed annually³—delivering desperately needed nutrients directly into the soil without the need for costly and environmentally degrading chemical fertilizers. Its rapidly decomposing leaves are also a great source of green manure and cattle fodder.

The fertilizer response curve, which dictates that upwards of 50% more agricultural output is created when non-fertilized land becomes minimally

fertilized, shows that natural fertilization through the leucaena tree would have an enormous impact in regions where fertilizer is currently un- or under-used. In addition, leucaena provides a renewable way to feed livestock. Its leaves have the



L Leucaena (pronounced loo-say-na)
grows 10 to 12 feet per year.

nutritive value of alfalfa and are a great protein source for cattle. It can feed humans as well, through harvesting of its beans, shoots, and seeds, which can be made into tempeh. It is a soil stabilizer and erosion controller, preventing vital nutrients in the soil from being washed away. It is an incredible source of raw materials, and can be used to make anything from paper, roofing felt and hardboard, to particleboard and rope. It is thus both a food and cash crop, sales of which can provide entry into local and global markets, as well as a sustainable source for organic fertilizer. It can also be used in symbiotic relationships with crops like cacao and coffee thereby providing additional crops for the economic development of the small farmer. And finally, critical to our funding strategy, due to its fast growth it sequesters carbon from the atmosphere at an unusually high rate, storing 50 lbs of carbon per year (forty trees will remove a ton of carbon from the atmosphere).



Leaves and seeds can be animal and human food and fodder.

Strategy

The Giving Tree Program will be part of a non-profit organization⁴ that cooperates with small farmers in developing countries to grow leucaena trees on their own land. The organization will claim carbon emission credits based on carbon sequestration through new tree growth. It will then sell the credits to heavy-polluting first-world corporations who are required to limit emissions as a result of the Kyoto Protocol.

The organization will primarily do three things:

- Employ local business people to work directly with farmers
- Provide training seminars for these business people
- Provide seeds

An initial grant from an appropriate foundation or government agency is needed to fund the Giving Tree demonstration program on 1,000 farms

Leucaena can grow under conditions of extreme drought.



throughout developing countries. Additional plantings will be made possible from revenues received through sales of carbon emission credits.

Based on current projections, the startup costs total \$3,865,000, which includes \$3,000,000 for an emission credit license, costs for seeds, staff, and land rental. The total cost of planting seeds is \$100 per farm. The same farm will generate \$300 per year in carbon emission credits based on current carbon market prices. The Giving Tree Program will have substantial profits with which to fund further tree plantings.

This model has been tested. We are aware of one example in which the Japanese government funded a similar operation to plant leucaena trees in Columbia, with positive results.

Finally, two factors make this an ideal time in history for such a venture. Rising oil prices make oil-based fertilizers increasingly prohibitive. The passing of the Kyoto Protocol means the market price of carbon emission credits is likely to rise. Kyoto Protocol Article 2.1 advocates protecting and enhancing sinks and reservoirs of greenhouse gases *while* promoting sustainable forms of agriculture. The Giving Tree strategy does both.

Conclusion

The Giving Tree strategy is an economically feasible way to directly target the Sustainable Development Goal. It represents a locally and globally appealing case and comes with fringe benefits. Playing an integral part in creating a preferable global food system for the future, this venture emerges during an ideal time in history with a window of opportunity.



Leucaena is an excellent source of firewood and lumber.



Leucaena leaves, which are 5% nitrogen, make an excellent animal fodder.

The Giving Tree Strategy Financial Summary

Total Investment: \$3,865,000

- **Startup:** \$3,265,000
 - **Seeds:** \$15 per farm x 1,000 farms = \$15,000
 - **Rental Capital:** \$50 per farm x 1,000 farms = \$50,000
 - **Training Program:** \$200,000
 - **Emission Credit License:** \$3,000,000
- **Running:** \$600,000 per year
 - **Salaries:** \$500,000
 - **Training:** \$100,000 per year

Needed Resources:

- **Materials:** Seeds, educational supplies, office, and supplies
- **Labor:** Administrators, traveling educators, thousands of local reps/investors.

Output:

- **Measurable Positive Results:** \$300 per farm in carbon emission credits, minus \$100 in total investment per farm = \$200 profit per farm. 1,000 farms provide \$200,000 profit per year. This will offset the cost of operating expenses after the first year. “Free” source of fertilizer, business opportunities, entry into local and global markets.

Endnotes

- 1 Elizabeth Becker, “Number of Hungry Rising, UN Report Says” *New York Times*, 12-8-04
- 2 Ruskin, F.R. (Ed.). (1984). *Leucaena: Promising Forage and Tree Crop for the Tropics*. Washington, D.C.: National Academy Press
- 3 Ibid.
- 4 It could possibly also be part of the UNDP, FAO, or UNEP.

2. SKY FARMS

URBAN FOOD PRODUCTION

By Daniel Eida, Jai Lakhanpal, Eric Rimpel, Allard Van Hoorn, Adrian Salinas Valdez

***Strategic Summary:** Sky Farms would rest on top of existing urban structures, producing food and energy, collecting water, and utilizing urban organic waste. This would increase food production, freshness and quality of food, and employment in urban areas by growing crops in enclosed structures on rooftops.*

Introduction

Over 50% of the world's total population, over 3.5 billion people, are living in urban areas. Over the next twenty years this percentage will rise to over 60% of the world living in urban environments. Most of these people are right now, and will be in the future, in developing regions of the world. Most of the urban poverty, and hence urban hunger, in the world is also in these developing regions. Un- or under-employment is also high. In addition, many of the recent arrivals to urban areas are former farmers who are escaping the poverty of the countryside brought about by increasing population, mechanization of farms, lack of land and other resources, and low commodity prices due to subsidized imports. These "agricultural specialists" have very valuable knowledge and experience that is, under usual urban conditions, at best severely discounted or, more likely, seen as worthless.

The need for additional supplies of fresh, affordable, high quality food as well as employment of both new urban emigrants and existing under- or unemployed urban residents is high. *Sky Farms* are a creative response to the opportunities of this situation.

Strategy

Sky Farms is the name of an organization (which could be a non- or for-profit corporation) that would establish farms on city rooftops. The farms would be in lightweight enclosed structures that rest on the top of high-rise urban buildings. The Sky Farm structures are in a flexible variety of models or configurations, including multiple levels. These urban greenhouse farms would be attached to the top of existing buildings and

begin growing food almost immediately. Rainwater will be collected from the structure to provide water for plants. Excess heat trapped by the structure will be pumped to heat or cool (via heat pumps) the building on which it is resting. Sky Farms would help transform buildings and cities into green buildings and green cities, being a valuable part of urban revitalization and economic growth—while supplying year-round sustainable supplies of fresh food to urban residents.

Costs

An average Sky Farm would be approximately 30,000 square feet and would cost \$3.00 per square foot to build and install in a developing region of the world. It is expected that such a structure would be able to eventually supply fresh vegetables for 1,000 people if intensive farming techniques were used. The \$90,000 building startup costs, coupled with maintenance, materials, and salaries would total approximately \$150,000. This would come to \$150 per person fed by the Sky Farm in the first year. Each year the Sky Farm would produce additional food for urban residents thereby lowering this startup cost per fed person to negligible amounts over five years. The annual costs of running the Sky Farm would include salaries for the two to three urban farmers who plant, cultivate, and harvest the crops and maintain the structure, as well as “rent” to the building owners and residents. These costs would be covered by the sale of the food crops produced.

Sky Farms would rest on top of existing urban structures, producing food and energy, collecting water, and utilizing urban organic waste.

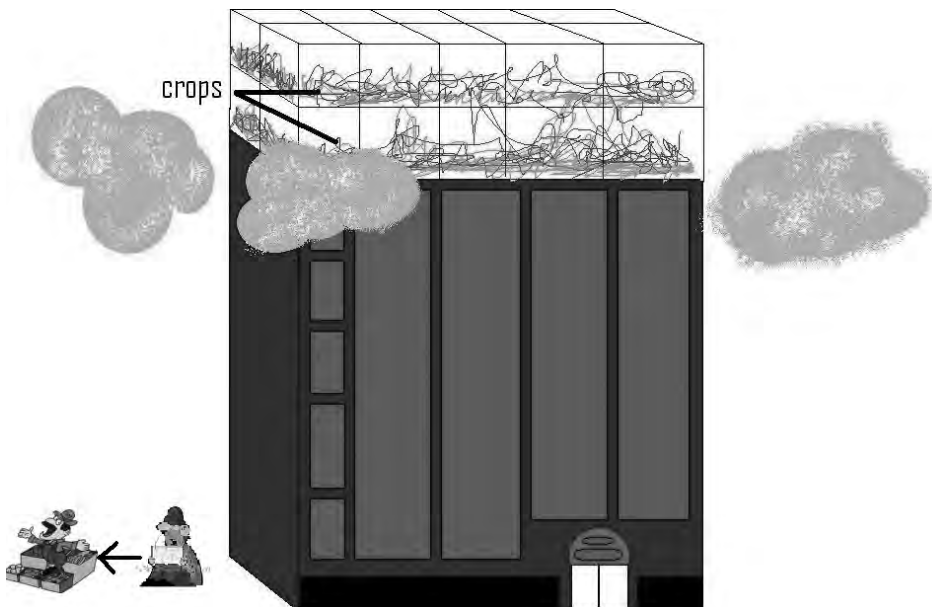

Implementation/Startup

Sky Farms would get off the ground in each city through a private sector initiative subsidized by government tax abatements, market guarantees, insurance, and regulation changes, where needed. Prospective buildings would be identified, inspected, and rooftop rights would be secured. These building could include apartment houses, factories and office buildings. A low-cost loan would be made available through the city government or local bank to fund startup costs. As the structure is being built, potential farmers would be identified and trained in urban rooftop food production and the maintenance of the Sky Farm.

Soil for growing the Sky Farm food will come from construction sites outside the city and will be supplemented by urban compost (see Trash to Treasure strategy, p. 32).

Impacts

The impacts of Sky Farms include increased urban food production, fresher and healthier produce, shorter lines of distribution and the savings of fuel for transportation, increased awareness of citizens, corporations and cities of green issues, better-fed urban residents, increased employment and tax revenues, lower cooling and heating costs, and lower sewage costs through rainwater collection and reuse.

3. SEVEN GENERATIONS: REGENERATIVE AGRICULTURE/ INTEGRATED CROPPING SYSTEMS

By Ilya Smirnoff and Eric Fedus

***Strategic Summary:** Increase food production, employment, and income through a knowledge-intensive agriculture that integrates multiple production techniques into one sustainable system. Simultaneously reduce expensive agriculture inputs such as fertilizer, pesticides, hormones, and antibiotics; improve water quality and availability; and slow or end desertification.*

Introduction

As indicated in *The Giving Tree* chapter, small farmers constitute nearly half of the hungry people in the world today. According to a 2005 report from the UN, there could be as many as 50 million additional refugees fleeing their home regions because of environmental breakdowns. Increasing food production, in environmentally sustainable or regenerative ways, is essential to helping the current situation and helping avert an even more disastrous situation in the future.

Strategy

Modern monoculture is “efficient” in the short term, as long as environmental impacts are ignored. Integrating a number of food production techniques into one food production system that more closely mimics natural systems is more productive¹ in both the short and long term. Growing crops on farmland that is fertilized with the waste products of other biological processes that are part of the food production regime makes both ecological and economic sense. As the illustration on p. 40 points out, waste products from meat and milk production can produce both fertilizer and energy that is used in other parts of the food production system.

Producing fish, animal meat and milk, traditional crops, algae, worms, chickens, and the so-called waste products of all these in an integrated system, where the inputs of one food production system are the outputs of another system, is simultaneously resource efficient, highly productive, economical, and environmentally regenerative. Such integrated food production systems are sustainable over the long term (“seven generations”) under tight resource limitations.

Integrated Farming System

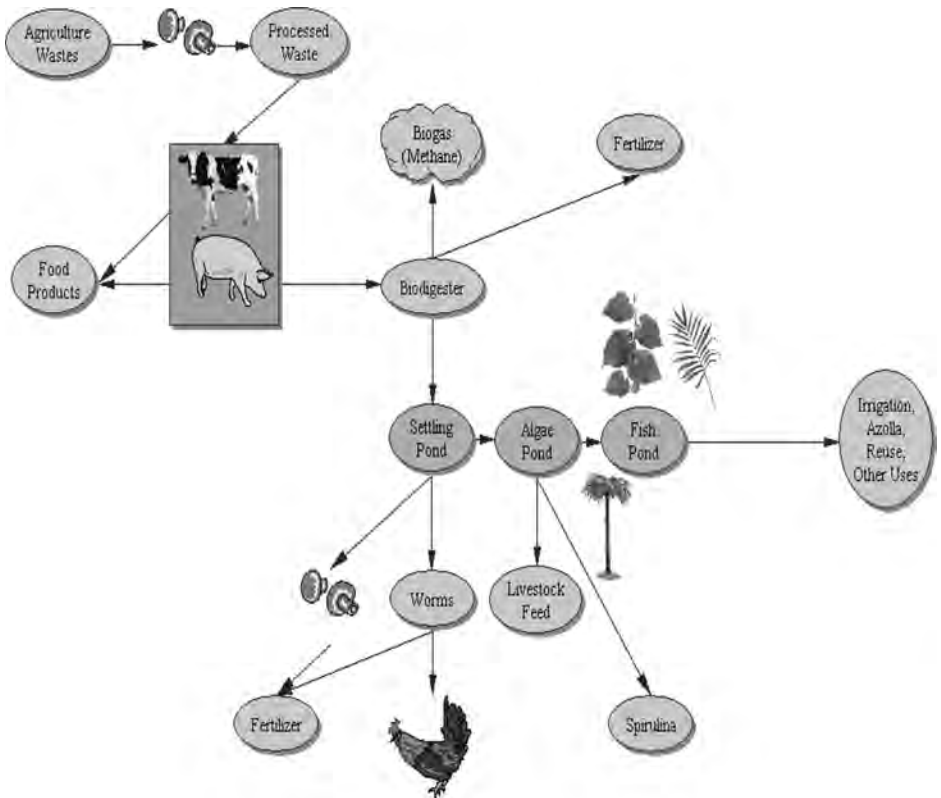

Regenerative agricultural methods include nutrient cycling, diverse production regimes, zero or minimum tillage (farming with little or no plowing), companion planting, diversified farms that raise both crops and livestock, composts, mulches, biological pest control, and soil and nutrient conservation, as well as water-conserving, small-scale drip irrigation, and post-harvest loss reduction. All these add together in ways that increase the health and productivity of agricultural lands and communities, and build economic wealth for the local area and world.

Widespread institution of these methods coupled with the increased availability of fertilizer would help guarantee both local abundance and future productivity.² In addition to increasing local food production and self-reliance, such an approach would decrease soil erosion and dependence on foreign imports of food and petrochemical products.

Furthermore, using locally available organic fertilizers and regenerative agriculture techniques would enhance crop resistance to drought and pests.³

The basic farm tools required to tap into local nitrogen fertilizer sources, expand irrigation, bring crops to market, and reduce the loss of crops due to insects and rodents can be manufactured domestically by any developing country, adding to its industrial production and providing employment.⁴ In addition, the incomes of farmers would rise with their higher productivity, even as their newly enriched croplands become more resistant to soil erosion and salinization.

Global Extension Service for Regenerative Agricultural Systems

To scale this food production system to the level where it has a significant impact on the food-short areas of the world will take a serious, persistent, locally implemented and globally facilitated development effort. It will involve an aggressive program for teaching and demonstrating regenerative farming methods to traditional small-scale farmers, coupled with financial incentives and economic safety nets that strongly encourage the switch-over. A global extension service for regenerative agricultural systems would be instituted to make the transition as smooth, risk-free, and fast as possible. Modeled after the highly successful US Agriculture Extension Service, it would assume responsibility for teaching regenerative farming techniques to food-short areas of the world—demonstrating fertilizer, irrigation, animal and cropping systems that build up the ecological underpinnings of our food supplies.

Key functions of this service would include providing on-farm extension workers on an order of magnitude greater than the world presently has, along with demonstration farms, education materials, transportation vehicles, communication equipment, tools and support facilities, and the financial incentives to encourage farmers to learn the new agriculture methods.⁵

New Wave Agriculture

“The Peacemaker taught us about the Seven Generations. He said, when you sit in council for the welfare of the people, you must not think of yourself or of your family, not even of your generation. He said make your decisions on behalf of the seven generations coming, so that they may enjoy what you have today.”

—Oren Lyons, (Seneca) Faithkeeper, Onondaga Nation

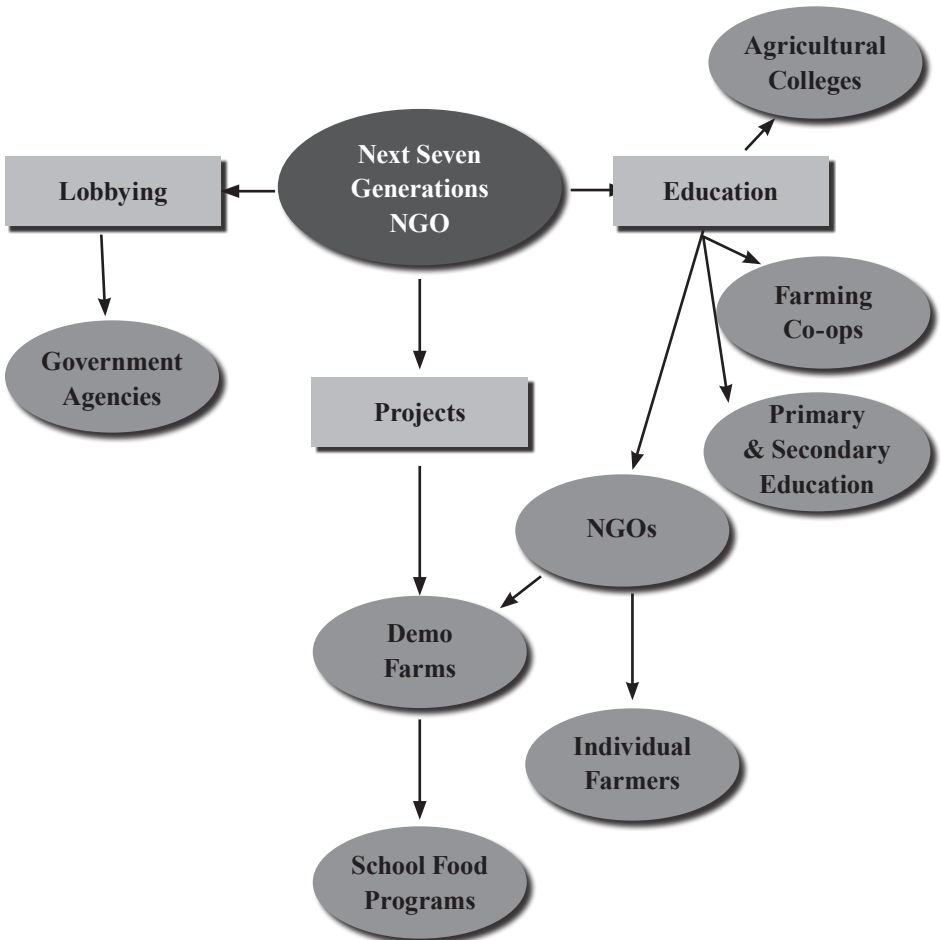

4. POST HARVEST LOSS COOL POT AND GRAIN GAIN

By Jeremy Bang and Arthur Steiner

Strategic Summary: Increase food availability by reducing post harvest loss.

Introduction

Addressing hunger throughout the world has taken on many forms, the tail end of which has as much to do with saving what is produced as it does with producing more. Current figures regarding post-harvest losses from all over the world range from 10% to 80% crop losses, depending on what you measure and the area in which the food is produced. The two specific areas where the most loss occurs are highly perishable foods (i.e. fruits and vegetables), and less perishable but highly important grains.

Fruits and vegetables in arid regions can have almost total post-harvest losses. Considering that most of these losses come from subsistence farmers, the effects are directly on the hungry population of the world. Whereas grain losses are mainly the misfortunes of those living below the poverty line, it become clear that curbing post-harvest losses directly impacts the success of the first sustainable development goal.

There are many strategies and techniques for reducing post harvest loss. Two of the most effective and affordable are the following:

The ‘pot-in-pot’ storage is a cheap electricity-free cooling system. The other is an efficient storage system for grains designed and distributed by a company called GrainPro.

Pot-in-Pot

The ‘pot-in-pot’ system is just as it sounds: one clay pot with a smaller pot inside of it that has a wet sand barrier in-between the two pots. Perishable food is placed in the inner pot and as the heat of the day evaporates water out of the sand barrier the food inside is kept at up to fourteen degrees cooler than the outside temperature, extending food life dramatically. For example, spinach in parts of Africa rots in one day, in the ‘pot-in-pot’ system, it can last twelve days.

The earthenware-cooling device





Earthenware cooling system to preserve perishable foods in developing countries with arid climates.

costs about \$.50 to produce. The ‘pot-in-pot’ system also creates local employment opportunities, especially in countries where unemployment rates and agricultural unemployment rates are very high. A factory that could produce these ‘pot-in-pot’ systems could employ people in local villages with a yearly operating cost estimated at \$14,000, and first-year profits estimated at \$7,000. The initial investment could come from governments, non-profit development organizations, or private enterprise. This strategy is capable of creating employment, increasing the amount of available food, increasing productivity, and still making a profit for the investors. It is an extremely attractive low-level solution to curbing hunger in sub-Saharan Africa and elsewhere.

GrainSafe

The grain storage system has similar results with improving grain storage. This has many implications for the profitability of the crop because it removes a bottleneck to people’s food needs, and lessens the need to get rid of rotting crops.

The grain storage system is simple yet effective: it consists of a large bag and a protective cylinder. The flexible white bag is impermeable to water, water vapor, and air. This allows the grain to be stored

and protected from one of the major elements that causes grain rot: moisture. The cylinder is made of polypropylene and further protects the grain from pests and other natural elements. The purchaser of this system would have to construct a platform that can be made from local resources such as wood, mud bricks, or bamboo. For further protection, this storage bin has a spout at the bottom allowing the farmer to dispense the desired amount of grain without exposing all of the stored grain to moisture and air. This storage method is simple enough so that the small-scale farmer would not have to acquire any expensive complex machinery but efficient enough to reduce post harvest losses to 1%.

The cost and expenses of this system are significantly lower compared with the benefits of reducing post-harvest losses, but in some cases financial help of a microfinance program may be necessary for the purchase. ProGrain has distributors in Bangladesh, China, Ethiopia, Ghana, India, Indonesia, Latin America, Turkey, Uganda, and other countries, making these storage bins accessible in many key areas needing improved grain storage.



Above left: assembly; Center: loading grain; Right: the finished GrainSafe. Below left: sealed bag; Right: extracting grain



Endnotes

- 1 More productive as measure by total output per hectare.
- 2 Various nomenclatures are used in different parts of the world and academia to describe the core practices here referred to as regenerative farming. These include alternative, sustainable, low-input, organic, agro-ecological, ecological, and information intensive agriculture. Each name comes with its own emphasis and nuances, but all are distinct from “modern” resource intensive, mechanized and large-scale agriculture.
- 3 See for example, M. Gabel, “The Regeneration of Africa: Resources, Needs and Capacities” (Philadelphia: World Game Institute, 1985) and M. Gabel and A. Heiland, “National Implications of Resource-efficient Farming Methods for Tanzania” (Emmaus, PA: Rodale Press Inc., 1985).
- 4 See, for example, M. Gabel and A. Heiland, “National Implications of Resource-efficient Farming Methods for Tanzania,” pp. 3-4. (Emmaus, PA: Rodale Press Inc., 1985)
- 5 Quoted text from *Seven Billion Billionaires*, Sierra Club Books/University of California Press, forthcoming 2006.

5. MORINGA IN MOTION

By Brent Jones, Michael Khayyat, Karen Lau, Lexi Quint, Zoe Richards, Alex Rinomato, Pollan Wong

Strategic Summary: *The moringa tree is a fast-growing, drought-resistant plant with highly nutritive leaves and the potential to be used in a number of small- and large-scale industrial processes. The stems, seeds, and leaves of the moringa tree can all be processed into useful byproducts and sold on local or world markets. Step one is creating seed banks and demonstration farms in villages where local farmers can come to get moringa seeds, learn about the plant, and deposit extra seeds for others to use. Step two is scaling up these seed banks/demonstration farms to a regional level after a pilot program.*

Present State of Wealth and Health in Less Developed Regions

In most less developed regions there is often a general lack of:

- infrastructure/transportation/roads
- communication tools (i.e. Internet connectivity)
- access to capital
- adequate supplies of food/water
- training/resources/education
- accessible and affordable healthcare
- small business opportunities

1.37 billion people live on less than \$1 per day⁷

1 billion people are chronically malnourished and approximately a third of the world's population lack food security

30% of children between the ages of one and five are underweight according to international standards⁸

203 million people are malnourished in sub-Saharan Africa

An analysis of long-term trends shows the distance between the richest and poorest countries was about:

- 3 to 1 in 1820
- 11 to 1 in 1913
- 35 to 1 in 1950
- 44 to 1 in 1973
- 72 to 1 in 1999

Micro loans are allowing some people opportunities to start small businesses and gain an income. However, the existing programs are

not widespread enough to be effective on a scale large enough to eliminate the problem.

Many farmers in less developed regions are forced to grow cash crops like cotton and rubber to supply raw materials to global markets. This can reduce food output and lead to soil erosion.

Preferred State of Wealth and Health in Less Developed Regions

By 2030:

Eradicating poverty in both urban and rural areas by facilitating the creation of local businesses that:

- Are sustainable, ecologically-sound, regenerative
- Have access to capital for further expansion
- Have access to adequate infrastructure
- Have access to training programs
- Are run by and employ locals
- Are as locally sourced in terms of resource use and other inputs as possible
- Are connected/networked with urban areas
- Provide affordable/free healthcare for employees



The above shows the overlap between where moringa is needed (areas with large numbers of malnourished people and struggling local economies) and where moringa grows.

- Create artifacts that help meet the basic needs of the community using surrounding resources
- Are able to connect globally via export/trade
- Create a globally networked world where people have Internet communication access to the outside world, where resources are shared, and motives and operations are transparent

Project Goals

By 2030, the following goals need to be met in order to consider this project a success:

- A large thriving market for the products produced from the moringa tree
- 10,000 moringa seed banks distributed throughout the developing world
- Unemployment rate reduced by 75%

The Moringa Tree

Moringa is a tropical multipurpose tree. It is resistant to drought and is fast growing. It also has a variety of uses from nutritional to industrial and can be marketed in the form of a number of different products, from cosmetics to food supplements.

Moringa Uses and Products

Aside from the ease of growing and cultivating moringa and its nutritive properties, the tree provides a number of other benefits.

Nutrition

One rounded tablespoon (8 g) of leaf powder will satisfy about 14% of the protein, 40% of the calcium, 23% of the iron and nearly all the vitamin A needs for a child aged one to three. Six rounded spoonfuls of leaf powder will satisfy nearly all of a woman's daily iron and calcium needs during pregnancy and breast-feeding.¹⁰

Moringa leaves can be easily dried (in the shade to reduce loss of vitamins) and rubbed over a wire screen to make a powder, which can be stored and conveniently added to soups, sauces, etc.

Water Purification

One hundred kg of moringa seeds will produce about 1kg of polyelectrolyte, a chemical compound which is used for water

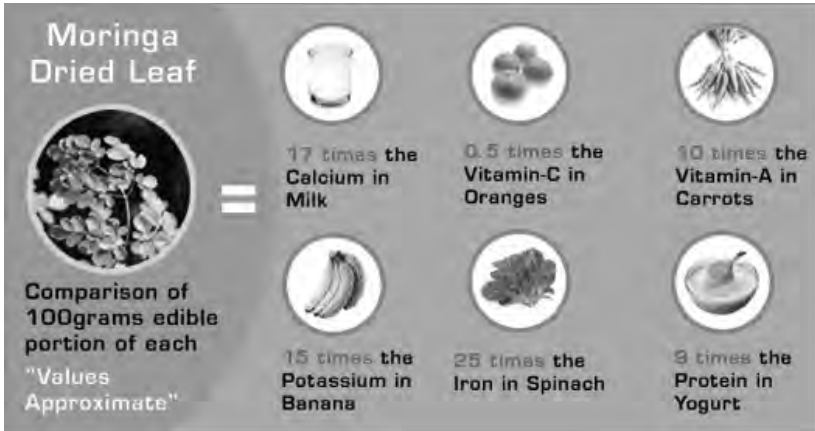

filtration; powder from ground-up seeds and also the presscake left over from the extraction of moringa oil can both be used for the treatment of turbid, dirty water.¹¹

Treatment of water with moringa is by no means a fail-safe measure, but where other methods are not available (or too costly), moringa is a great alternative and certainly better than drinking untreated water.

Antibiotic

A compound found in the flowers and roots of the moringa tree, pterygospermin, has powerful antibiotic and fungicidal effects.

Fresh Food and Drink

The young pods, when cooked, taste like asparagus. They are sold fresh and canned in many Asian markets. Tinned drumsticks are exported from India, Sri Lanka and Kenya to Europe and Asia. They are eaten much like green beans.

After about 8 months, the tree begins to flower and continues to flower year round. The flowers can be eaten or used to make a tea. In Haiti tea from the flowers is considered a powerful cold remedy. The flowers provide good amounts of both calcium and potassium.

Moringa seeds can be extracted and eaten as "peas" (boiled or fried) when still green. The mature seed is about 40% oil. Moringa oil is of excellent quality for cooking. It is used in cooking, perfumes and as a watch lubrication. It is also used for making soap and—when burned in lamps—for light as well. The oil is slow to become rancid.¹²

Strategy

This strategy takes place in three stages, starting with Phase 1 in 2010 proceeding through Phase 3 in 2015.

Phase 1

The first phase of the Moringa in Motion strategy will function as a pilot program to determine what works, what needs adjustment, and what aspects of the project may not work in a given location. A target village will be identified for the pilot program and provided with:

- Moringa seeds
- Fertilizers
- Basic training in moringa cultivation as part of an Agricultural Resource Center (ARC), which will also provide basic information about a number of other local staple crops, water management and conservation training, and communications infrastructure (i.e., phone line, Internet connection—if needed)
- Creation of a growers cooperative network linking farmers from the village and region to markets and to each other to share knowledge

This phase will also be the first attempt at growing, marketing, and selling moringa products. The first product identified is Morigina leaf powder.

Once the pilot portion of Phase 1 is well-established, the project will be expanded to several nearby villages and the networking aspects of the strategy will begin to develop.

This will be accomplished by establishing additional ARCs with transportation and communication links in the surrounding markets. In this way, a small, regional market for moringa seeds, byproducts, and cultivation know-how will be created as well as a support system for general agricultural needs.

Phase 2

Following the initial pilot program and its regional expansion, the Moringa in Motion strategy will enter Phase 2. This will be a scaled-up expansion with a focus on broadening the market, expanding into other moringa product sales areas, and pursuing larger-scale manufacturing of moringa products. Several components of this phase are:

- Expanding the reach of existing ARC centers and building additional regional centers

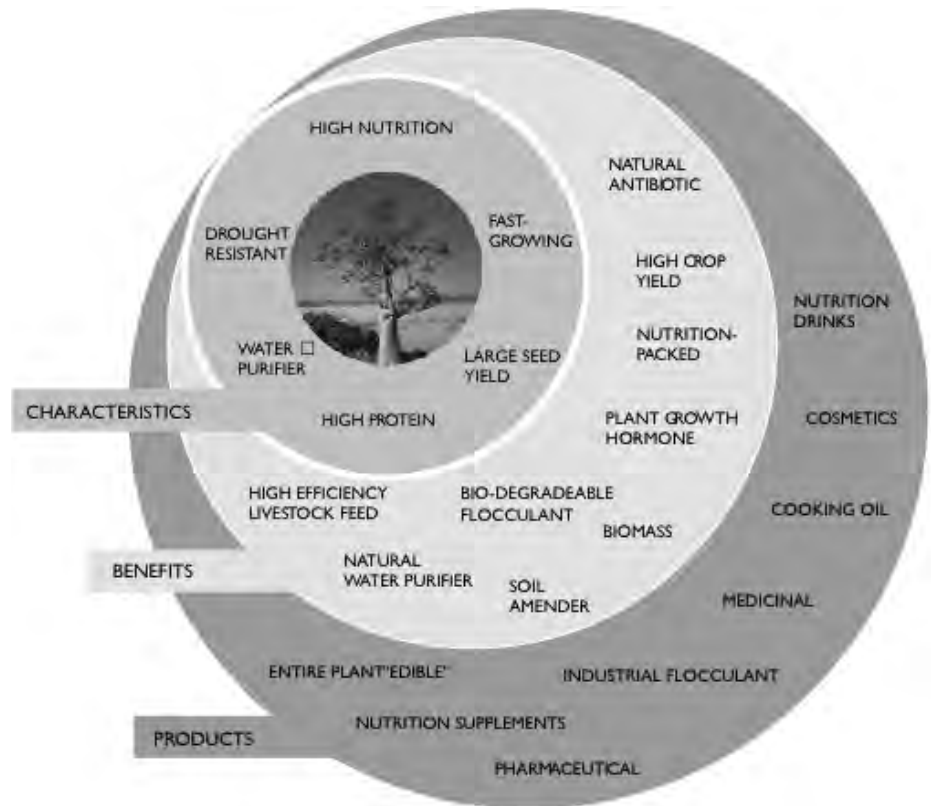

As depicted above, the moringa tree and its various parts can be used in a variety of ways to address poverty in all its forms and manifestations. While the most pressing need for the moringa may be as a source of food, the tree fulfills numerous secondary roles from water purification to fertilizer production. The moringa tree alone cannot solve the problem of poverty in less developed regions, but it will provide a solid foundation for health and wealth to build from.

- Drawing foreign investment into local moringa production efforts to expand production, begin global marketing initiatives, and create a brand
- Expanding seed collection and distribution for water treatment

Phase 3

The primary goal of this phase of the strategy is to move moringa production towards a self-sustaining endeavor, decreasing and eliminating the need for foreign capital and other assistance and placing

the entire operation in the hands of locals. This phase will focus on expanding the market for moringa products, investing in more and better infrastructure linking villages producing moringa to market centers, and investing profits from the enterprise directly into social support and services such as healthcare, education, and job training.

The ability of this strategy to be scaled-up dramatically is one of its greatest strengths. The images on the following pages illustrate this scaling process.

Projected Costs

PHASE 1: STARTUP COST

- (1 Agricultural Center + Outpost Network)
- Staff: Agricultural Extension Agent knowledgeable in moringa cultivation, product development, and marketing
- 3 Bikes
- 1/2 ton fertilizer/farm
- 2,000 seeds/farm
- 2 oil presses
- Packaging
- Water Management Tools + Techniques
- Main Agricultural Center
- Outposts/Storage Center

\$165,000 (\$300/acre of farmland)

YEARLY COSTS:

Labor Cost:

- (\$30/day labor for two local farmers X 260 days of labor) = \$15,600 labor
- Ag Extension Agent = \$25,000

\$40,600

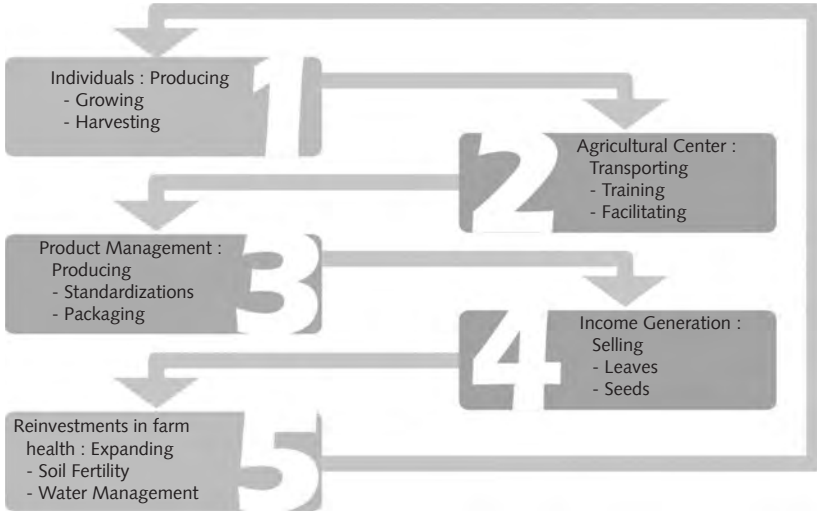

Long-term plan for the expansion of moringa-based enterprises.

From

UNITED NATIONS

- Provide seed funding, create farmer incentive from WFP/UNICEF
- WFP can buy this product to decrease malnutrition significantly

CIVIL SOCIETY

- People can buy the product and/or increase the awareness of Moringa
- Development of moringa production in developing countries

BUSINESS

- Market expansion (increasing production and distribution + awareness channels)
- Then energy market in the US alone is upwards of \$200 million. If we captured only 1% of this market with moringa products that would be \$2 million.

INDIVIDUALS

- Support for development of moringa production in developing countries

6. E.A.T.: EDUCATING AQUAPONIC TECHNOLOGY

By Anna Swarbrick, Runo Okiomah, Hein Lam, Donovan Preddy

***Strategic Summary:** Hunger exists for a variety of political, economic and environmental reasons. The fundamentally result, no matter what the cause, is the inability of a person, family or society to get access to a regular, affordable, and sustainable supply of food. When all else has failed, a humane society is left with no other option than to mount expensive famine-relief efforts. The strategy presented here takes an anticipatory approach to hunger. Its goal is to provide the resources and knowledge needed to generate enough food in each region of the world so that basic food needs are met locally. It does this through the relatively new technology of aquaponics and a creative education and distribution method of this technology.*

PROBLEM/PRESENT STATE

A Global Epidemic

Hunger is one of the most serious problems facing the world in the 21st century. Close to one billion people are “chronically hungry”, which means their hunger is long-lasting or recurrent.

A Dynamic Problem

Hunger is complicated. It can come in many forms and is often complicated by malnutrition, or “the condition that develops when the body does not get the right amount of the vitamins, minerals, and other nutrients it needs to maintain healthy tissues and organ function.”¹

The Urban State Of Affairs

By 2050, 70% of the world’s population will live in an urban environment.² The global solution to hunger will need to take this trend into account to be successful. While it may not seem possible for such densely-populated areas to produce most, if not all of the needed food for its residents, the story of Havana, Cuba suggests otherwise. This city serves as a example of a self-sufficient habitat, one that has created a ripple effect of positive, social benefits.

Throughout the mid- to late-twentieth century, Cuba developed a strong dependence on the former Soviet Union for resources like fuel and food. In 1991, when the communist regime in the Soviet Union collapsed, Cuba lost not only its petroleum, but its steady supply of imported food. As a way of coping with this problem, Cuba decentralized its food production and shifted its focus from large state farms to more urban-based cultivation systems. Today, more than 50 percent of Havana's fresh produce is grown within the city limits. Furthermore, 350,000 new well-paying jobs have been created,³ four million tones of fruit and vegetable are produced annually⁴ and the city now has 2.2 million agriculturally, self-sufficient inhabitants.

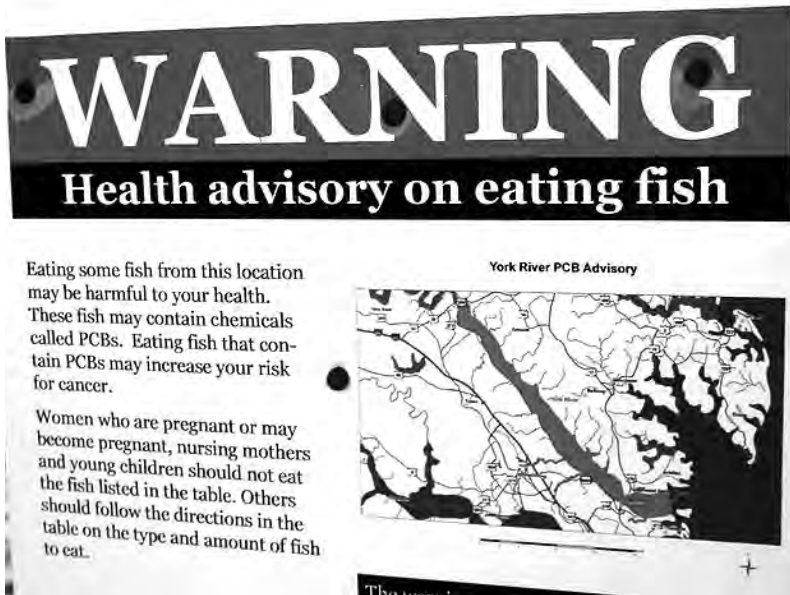

Unfortunately, this example is more of the exception than the rule. As cities become denser, finding arable land for food production becomes increasingly difficult. The production of protein-based foods is also something cities are no longer able to sustain. While many cities are located along major rivers and water ways, most of those bodies of water can no longer provide residents with sustainable supplies of healthy, protein-rich fish due to pollution.



STRATEGY

Aquaponic Technology

Aquaponics is a sustainable food production system that is a combination of two unique methods of growing food: hydroponics and aquaculture. It is a symbiotic environment wherein water, purified through a hydroponic system, is fed into a fish tank. Water from the fish tank, rich in nutrients from fish excrement, is then pumped through the hydroponic system as a way of providing the plants with the nutrients they need. The fish feed the plants and the plants provide the fish with clean water. This closed-loop system provides aquaponic farmers with a steady supply of the fruits, vegetables and fish needed to sustain a healthy active lifestyle.

Aquaponics has a number of proven, tangible benefits that make it an excellent option around the globe. When compared to traditional soil-based growing methods, it has been found to use less water and energy and can pro-



duce more crop yield. When communities take control of this technology, it can foster financial and agricultural independence while supplying food that is organic, natural and healthy. In addition, community-based systems provide food which requires little to no transportation or refrigeration. Aquaponics proponents also claim that aquaponic systems also eliminates soil-borne diseases and have no weeds.

Aquaponics is ideally suited for producing high quality, affordable protein in sustainable ways in urban environments. Unfortunately, its use is hampered by the lack of knowledge about its capacities and the resources and technology needed to make it work.

The strategy presented here calls for the development of a global aquaponics knowledge network about individual and urban aquaponics food production. One way of spreading this knowledge network and the advancement of aquaponic technology is through a school-base competition. The scaling up of such a strategy could have a positive impact on reducing hunger around the world.

The Utility of Competition

Competition has long been an effective way to motivate behavior. One contemporary example that is relevant is a high-school league in the United States called *F.I.R.S.T. Robotics*. Started in 1992 by inventor/designer Dean Kamen, this league challenges students to build robots that are able to accomplish certain tasks established at the onset of each season. The robots then compete in local, regional and national events. For example, one year, the robots had to be able to pick up inflated inner-tubes and hang them from a metal structure. The goal of this league goes much deeper than the practice of building inventive robots.

As the *F.I.R.S.T.* literature says, its purpose is “To transform our culture by creating a world where science and technology are celebrated and where young people dream of becoming science and technology leaders.”⁵

What makes this league so effective (hundreds of schools and thousands of students take part) is the way the competitive season is structured. Each team begins the season with a competition kit that includes all the basic components needed to construct a robot. Because each team starts at the same point, the league promotes qualities in students like collaboration, innovation and “gracious professionalism.”

A BUSINESS OF SERVICE DISTRIBUTION

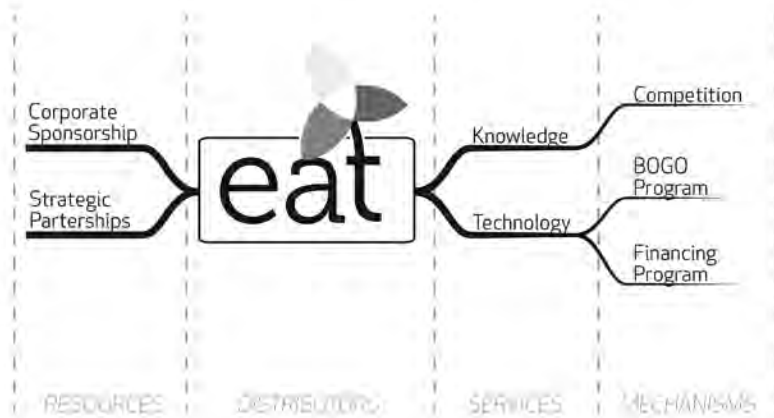

Putting It Together

Aquaponic technology is already making a contribution to food production in some areas. Unfortunately, this contribution is largely based in developed countries like the United States and Australia. This strategy aims to spread aquaponic knowledge and technology in developed and developing countries through a F.I.R.S.T-like competition. Our competition is called E.A.T. (Educating Aquaponic Technology). It works in the following way:

There are two teams that are paired. A team in a developed country, like the US, would raise money to cover an entry fee. For the price of this fee, they would receive a basic aquaponic starter kit that would include items like a water pump, growing medium, seeds, etc. At the same time, a second starter kit would be sent to a school in a developing country like Nigeria. These two schools become a single team that works together.

Each year, the challenge to the paired schools is to grow the most food. The winner is the team that has, collectively, produced the most fruit, vegetables and fish. Each season the challenge shifts to a different type of food that is to be grown. The systems developed by each team needs to be optimized for that year's particular challenge. Points will also be awarded for categories such as the degree of innovative design.

Each team will also need to document their work so that as the year's go by there will be a build-up of designs and knowledge that can be accessed by other people around the world.

At the end of each season, all school teams would donate their constructed aquaponic systems to eligible candidates in their respective communities. This would create a flow of food-producing systems and knowledgeable individuals throughout the world.

BUSINESS MODEL: Overview

Educating Aquaponics Technology (EAT) would be created as a 501(c)(3) non-profit organization to facilitate the dissemination of aquaponics technology and knowledge across the developed and developing world. The methodology for dissemination is the E.A.T. Competition.

The goal of the EAT business model is the efficient dissemination of the technology and knowledge of aquaponics. It aims to be socially responsible, environmentally sustainable and economically profitable.

The strategy's preferred state envisions a society where every community grows at least some of their own food. To accomplish this vision, the strategy will disseminate aquaponics technology, knowledge and hardware.



Corporate Sponsorship

The E.A.T. business model needs a capital investment from corporate or foundation sponsors. These start-up sponsors could consist of industry leaders in agro-production, or large agribusinesses interested in securing the allegiance of a young and growing demographic of independent growers. Companies like John Deere, Burpee Seeds, Del Monte etc. could take on this challenge and receive tax breaks for their financial contributions. Aquaponics kit suppliers could also donate starter kits for this venture, and other corporations, like Coca-Cola, could become joint sponsors. In return, sponsors could get advertising space and branding rights on the E.A.T. Challenge as well as on the aquaponics kit-of-parts.

Strategic Partnerships

As the financing is secured through sponsorships, strategic partnerships with educational systems will also be developed. There are strong

support networks for schools that exist at the local, regional and global level that are typically linked with non-governmental organizations and international government organizations like UNICEF and UNDP. These organizations are well acquainted with the locations, existing resources and monitored academic standards of schools across the globe. EAT is a value-adding business that will equip young people to grow food for their community.

**Knowledge Distribution:
Competitions**

EAT is in the business of distribution, disseminating technology and knowledge to communities via the education of youth. EAT maintains interest among youth via competitions that serve the dual purpose of capturing the interest of young minds in innovative projects and also providing the conduit for aquaponics knowledge transfer. After supplying the aquaponics technology and knowledge at the schools we are affiliated with via the NGOs and IGOs network, we ignite the youths’ ingenuity and excitement by pitting schools against each other in competitions, with expenses covered by our corporate sponsors.

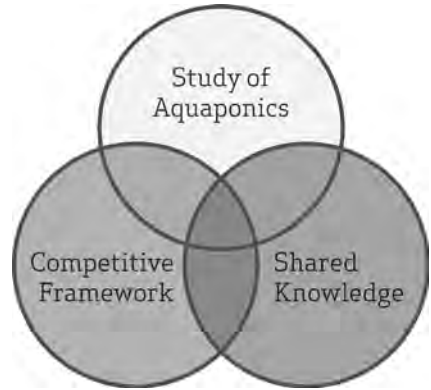

COMPETITION TEAMS: A PARTNERSHIP

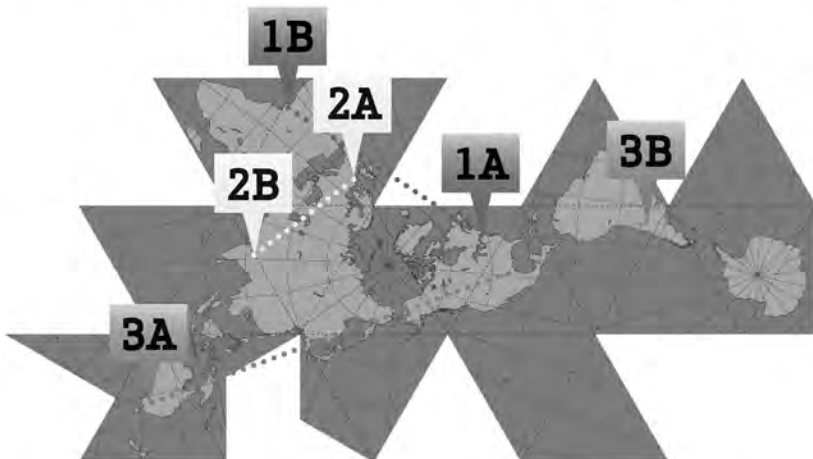

Summary

The dissemination of knowledge and technology happens through the supply of aquaponics kits that are funded by contest entry fees and corporate sponsors. The “Buy one give one” model is cost-effective. It is similar to the successful model used at Tom’s Shoes. Once a school in the developed world pays its entry fee or is sponsored to receive an aquaponics kit, there is a donation of a similar kit-of-parts to another school in the developing world. This “sister-school” partnership is tasked with jointly optimizing the aquaponics systems’ output.

As this strategy unfolds, young students will become conversant with aquaponics technologies and capable of growing some of their community’s food. EAT is strategically poised to supply these aquaponics kit-of-parts to the interested schools and students who see the financial value of expanding aquaponics production at the community level.

Endnotes

- 1 <http://medical-dictionary.thefreedictionary.com/malnutrition>
- 2 Anna Tibaijuka, director of UN-Habitat
- 3 Nelso Companioni Concepción, *La Agricultura Urbana: Un Sistema Alternativa de Produccion de Alimentos en Cuba*, powerpoint presentation, slide 35, INIFAT, la Habana, 2007
- 4 Adolfo A. Rodríguez Nodals, Nelso Companioni Concepción, and Rosalia González Bayón, “La Agricultura Urbana y Periurbana en Cuba: Un Ejemplo de Agricultura Sostenible,” Powerpoint Presentation, slide 9, presented at the VI Encuentro de Agricultura Organica, May 2006, Havana
- 5 <http://www.usfirst.org/aboutus/content.aspx?id=34>

7. ANTEATERS INC.

By Emily Yung, April Garcia, Zander Tippett, Ketevan Grdzelizde

Strategic Summary: *There are serious shortages of food in many parts of the world. Insects have been consumed by humans throughout recorded history in many parts of the world. They have high nutrient value, can be mass-produced locally, consume local waste, produce valuable waste products, and are affordable. This strategy uses these advantages in ways that could increase food production and provide local employment in sustainable ways.*

Introduction

“What we eat is, after all, more a matter of custom and fashion than anything else... It can be attributed only to prejudice, that civilized man of today shows such a decided aversion to including any six-legged creatures in his diet.”

—naturalist Joseph Charles Bequaert

Currently, 842 million people in the world do not have enough to eat, with the majority in Asia and the Pacific region.¹ Poor nutrition causes nearly half of all the deaths of children—3.1 million children per year.² These statistics are but a few that demonstrate the need for change. The world needs something that will provide nutrition, eliminate

stunted growth and undernourishment. Ideally, food sources would be self-sustaining economically and environmentally. It is also important to have equal opportunities for both male and female farmers, everyone should have access to adequate storage facilities and techniques, and the food products that are produced should be highly nutritious and marketable.

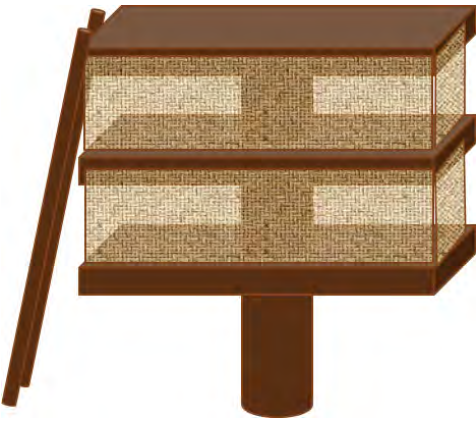

Strategy

To combat the lack of nutrition, a new company, *AntEaters Inc.*, plans to create and distribute relatively small-scale insect farms. The insects produced in these farms would not necessarily replace meat in local diets; rather, the insects would serve as a protein and vitamin supplement. Insects have been proven to be high in nutrients; they are made of 30%-70% protein on a dry matter basis.³ Although there is a negative cultural stigma surrounding the consumption of insects in many Western societies, insects are high in protein, reproduce quickly, take up less space than livestock, and require less feed than livestock. The insects would be farmed using a vertical farming model, as shown above.

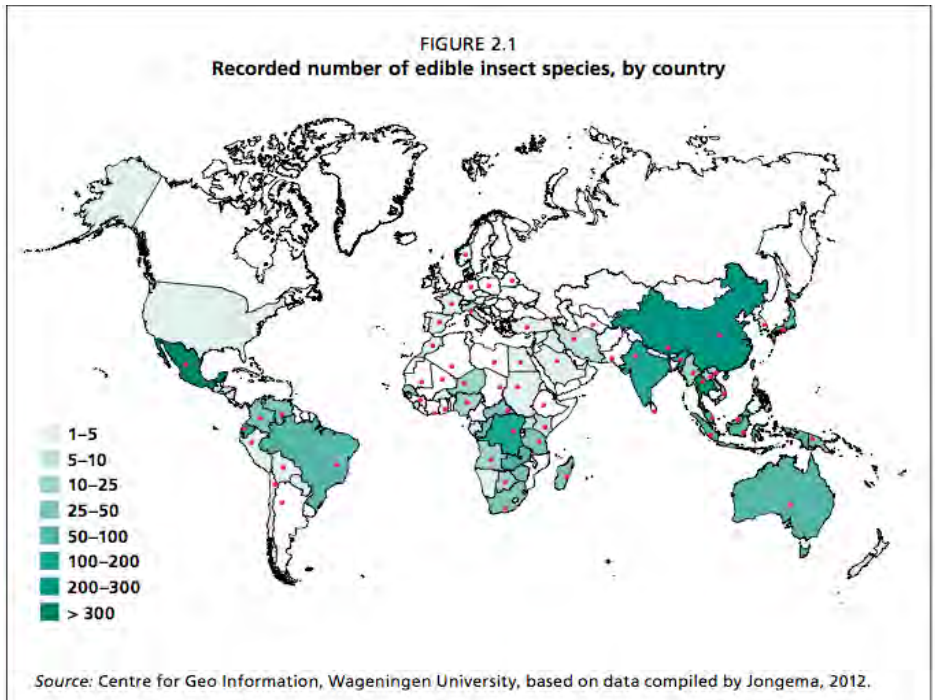

Map Source⁴

Insect Farms

AntEaters Inc. would manufacture “Insect Farm Start-Up Kits.” These startup kits will be marketed primarily in areas that suffer from malnutrition. The kits will include burlap and wood to construct the

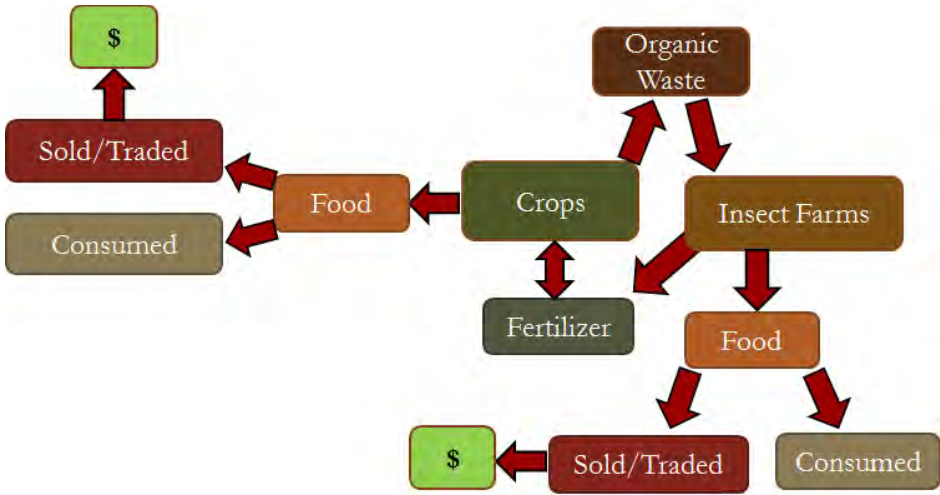

vertical farm, insect feed, live insects and complete instructions. Video instructions would also be available on YouTube. All insects would be native to the region to which the kits are sent, thereby preventing the introduction of invasive species. After using up the initial supply of insect feed, the insect farm will use organic waste as feedstock.

The chart below demonstrates the ways that insect farms could be introduced to communities. Not only would they provide additional nutrition to consumers, but they could also be sold and manufactured, which would be a source of more local jobs.

Database

In addition to the insect farms, *AntEaters Inc.* will provide a database containing information about the insects. The database will be available on both the web and smartphone. Users will be able to search by region of the world or name of the insect. Specific information will include how and where to grow different species as well as recipes, photos, prices, and types of insects.

The database will also include fundraising information and a link for donations. If users donate a certain amount of money to fund an insect farm, they will receive recognition and a gift. These incentives include bugs, t-shirts, tote bags, and hats.

Pilot Program and Resources

AntEaters Inc. will start with a series of pilot programs in at least five different geographic regions of the world and with different insects. Ten startup kits will be delivered to appropriate urban partners and another 10 to rural partners. The initiative will require suppliers, regional distributors, local farmers, households and a market for surplus crops. For the pilot program, *AntEaters Inc.* will ship all materials and insects to the location. As pilot programs grow to successful enterprises, materials and supplies will be produced and distributed locally.

Cost for Pilot Program Materials

1. Delivery method/ shipping for kits: by plane, \$4.99/lb⁵. Weight of the insect kit is ten pounds.
2. Kits (what's inside):
 - Insects (50 locusts): \$23⁶
 - Insect feed: \$4
 - Structure, containers: (estimated) \$40 + \$10 = \$50
 - Estimated total per kit: \$77

Total materials cost for pilot program: \$77 x 20 kits = \$ 1540

Conclusion

Insect farms are practical, sustainable nutrient supplements. Many areas of the world already consume insects; these areas would greatly benefit from farming insects to consume and sell. *AntEaters Inc.* provides the materials and database information to successfully integrate insect farms into urban and rural communities that suffer from malnutrition—or that would find insects a valuable addition to their diet.

Endnotes

- 1 <http://www.wfp.org/hunger/stats>
- 2 <http://www.wfp.org/hunger/stats>
- 3 https://www.wageningenur.nl/upload_mm/2/8/0/f26765b9-98b2-49a7-ae43-5251c5b694f6_234247%5B1%5D
- 4 “The UN Suggests You Eat More Insects” <http://www.floatingpath.com/2013/05/13/the-u-n-suggests-eat-more-insects/>
- 5 <http://www.amazon.com/gp/help/customer/display.html?nodeId=596188>
- 6 <http://www.reptiles.swelluk.com/reptile-supplies/reptile-livefood-933/bulk-bags--1416/swell-livefood-locusts-bulk-186880.html>



STRATEGIC AREA II: WATER MANAGEMENT

8. Drops for Crops

9. WaterWorks

10. Water = Life

11. Increasing Household Water Security

12. Sanitation and Waste Management in Informal Communities: Dharavi, India

8. DROPS FOR CROPS

By John Yuan

***Strategic Summary:** Increase food production through increased use of water-efficient irrigation.*

Introduction

Not only is water essential for human survival, it is needed for producing crops. Irrigated farmland, which accounts for less than 20% of global food production land, produces 40% of all food.²⁷ Irrigation increases yields of most crops by 100% to 400%.²⁸

Rainwater Harvesting

There are a number of innovative ways of “harvesting” water in arid regions of the world. One set of technologies revolve around rainwater catchments. The goal here is to capture and store rain water when and where it is abundant, often times in super-abundant quantities, for use in the dry season. The Kuis method of rainwater harvesting is from western India. It involves the digging of a crater, at the bottom of which is a tiny opening leading into a hole where the water is stored and kept from evaporating. Heavy rainfall gathers in the craters where it then flows into the water holding hole. Once the holes are built, they will last for years and years. Water stored in these holes can be channeled into wells and irrigation systems for use in water short seasons.



Fog Harvesting

Another techniques for gathering water in arid regions is what is called “fog harvesting.” This technique is good for arid climates where access to water is seriously limited. It involves the use of a net that lets humid early morning air pass through. As the air goes through the netting, its moisture collects and drips into the gutter at the bottom of the net. From here, the water flows into a collection basin where it is stored until needed.



Drip Irrigation

Another technique for meeting the water needs of water-short areas is through the conservation of this scarce resource. The largest user of water is irrigation. In most parts of the world, including wealthy areas such as the US, irrigation water uses 50% or more of all fresh water. Using the least efficient irrigation technique, that of open field flooding, wastes 70 to 90% of the water.

Drip irrigation is a method of irrigation particularly suitable to arid climates where water is scarce. It is also suitable to any climate where there is an interest in conserving water. Precise water application is possible and runoff is eliminated, thereby reducing erosion and loss of soil nutrients. Drip irrigation is also helpful in other ways—it allows precise application of nutrients to depleted soils.

The primary disadvantage of drip irrigation is that it is more expensive in the short term. In the US it costs between \$500 and \$1,000 per acre, depending on the technology used. In the developing world, there are low-cost drip irrigation techniques that utilize bamboo or inexpensive plastic tubing. Using these materials, illustrated below and at right, the cost for drip irrigation is an order of magnitude lower. Water savings and increased crop production will pay for the apparatus in less than one season.



The “curled” micro-tube dripper: simple, low cost, if it clogs, one can simply blow through it to clean out the clog.

The bucket kit for low cost drip irrigation in the test laboratory of IDE India near New Delhi. A simple product with a long trial-and-error phase to make it suited to the needs of poor horticulturists.



9. WATERWORKS

By Devin Massaro, Nathan Owens, Bryce Langlotz, Tyler Knowlton, Jake O'Donnell, Barbara Kreider

***Strategic Summary:** Safe, clean, affordable and sustainable supplies of drinking water can be made accessible to poor people in developing countries throughout the world using existing technology. The funding for this technology comes from people living in developed countries through the savings that they accrue from water-conservation measures they implement in their homes, offices and schools.*

Introduction—Problem State

- Over one billion people lack access to safe drinking water supplies.
- 1.6 billion people lack adequate sanitation.
- Diseases related to unsafe water, sanitation and hygiene result in an estimated 1.7 million deaths every year. A child dies every eight seconds from contaminated water.
- Annually, water related diseases—cholera, hepatitis, dengue fever, malaria, and other parasitic diseases—cause four million deaths.
- Humans struggle to distinguish safe from unsafe drinking water.



- Natural processes may be insufficient to purify scarce and variable water supplies.
- Contamination of water supply comes from inadequate sanitation.
- Water consumption causes disease in humans when infectious agents are present in sufficient quantity.
- Climate changes are likely to further exacerbate the lack of water in water-poor areas.



Strategy

Preferred State

Everyone in the world has safe, abundant, affordable and sustainable supplies of drinking water.

More specifically:

By 2015, resources for 100,000 individual and 5,000 home water purification systems are provided annually.

By 2030, resources for 250,000 individual and 10,000 home water purification systems are provided annually.

Strategy—WaterWorks

Reaching the preferred state requires a complicated series of actions. Providing water purification systems to those who need them involves technology, policy, distribution and funding, among other things. The WaterWorks strategy is focused primarily on an innovative financing design that raises the funds needed for the purchase of clean water technology for the developing world.

The core of the WaterWorks strategy involves two major initiatives. One is the raising of money in relatively wealthy developed countries through an incentives-laden water conservation program that saves money for the wealthy water consumer (as it reduces their water use). These monetary savings are split between the wealthy water consumer and the program delivering clean water technology (individual and home water purifiers) to the people in need in the developing world.

Hardware—Water Purification Technology

The primary technology required for WaterWorks is water purification. Many systems are currently available. Some of these include LifeStraw and the Kisii filter.



Water purifier system for a family—the ideal water purification system would be produced by and in the communities where they will be used.

| Product | Purifier Cost (\$) | Filtration Speed (L/Day) | Filter Life (Months) | Filter Replacement Cost (\$) | Built For (# of people) | Portable? |
|---------------------------------|--------------------|--------------------------|----------------------|------------------------------|-------------------------|-----------|
| Life Straw | 5 | — | 12 | — | 1 | yes |
| Ceramic Water Pot | 15 | 50 | 18 | 4 | 10 | no |
| Kisii Water Filter (High Speed) | 3 | 25 | 6 | 4 | 5 | no |
| Kisii Water Filter (Low Speed) | 1 | 3 | 6 | 2 | 1 | no |
| Biosand Filter | 75 | 75 | 18 | — | 15 | no |

Software—Water Conservation

The second core initiative of this strategy is partnering with an experienced NGO that has a long-standing and trusted presence in the delivery of clean water systems in developing countries. As a way of locating the most appropriate NGO, WaterWorks will issue an RFP (request for proposal) from clean water delivering NGOs. The funds raised through the WaterWorks water conservation program in wealthy parts of the world will be funneled to the chosen NGO (or NGOs) to fund their clean water programs.

In summary: The WaterWorks strategy uses the funds saved as a result of water conservation taken by intense water users to pay for the technology to get clean water to those most in need.

The money-raising strategy requires robust participation by municipal water users in an incentivized water conservation program. Water users will be enrolled in a water conservation program as a way of saving money on their water bill. Fifty percent of the water bill savings will be used as seed money to fund the “WaterWorks” program of obtaining and delivering water purification technology to those in need in the developing world.

In order to attract large numbers of consumers to the program we will announce the incentives for the water conservation program on the bills consumers receive from the local municipality’s water departments. Other citywide advertising programs, such as direct mail, social networking websites, and school-based programs will also be conducted to get the word out. Educational outreach will continue until there is at least a 50% participation rate.

When funds begin to come in from the savings in water bills, water purifiers will be obtained and distributed through the partner NGO.

NGOs with experience in distributing water purification systems will provide distribution services as well as micro-credit services. Should better water purification systems be developed, this strategy calls for their use instead of the Life Straws or ceramic pot filtration systems described below. The idea is to always be using the best, most efficient, low-cost, and sustainable technology matched to local needs.

Local Partner

An existing company that is currently doing something structurally similar to what we are proposing is RecycleBank. This company has an incentives laden program that rewards people for recycling trash. They contact with municipalities to manage trash recycling. RecycleBank currently provides rewards for curbside recycling and e-waste management (electronic devices). WaterWorks will work with Recycle Bank on expanding and modifying their successful program so that it can handle water conservation.



Here is a model of how it will work: when consumers, domestic and industrial, receive their water bill, they will receive information about how much water they have conserved relative to the previous year's usage. Consumers will be given a link to RecycleBank. On RecycleBank, consumers can translate their savings in water into points that can be used to purchase rewards or donate money to WaterWorks, the not-for-profit company that provides water purification systems to areas with unsafe drinking water.

The WaterWorks strategy adds a third category to the Recycle Bank business: water conservation.

Model WaterWorks Water Bill

When a consumer logs in to the WaterWorks water conservation site, they:

1. Learn how to conserve water in their home, business and community.
2. Learn about global water issues.
3. Donate money to WaterWorks and direct where (what country) those funds should go.
4. Redeem points for rewards.

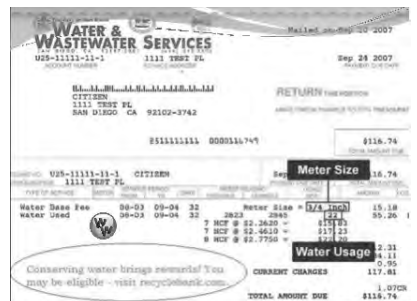

Action Plan

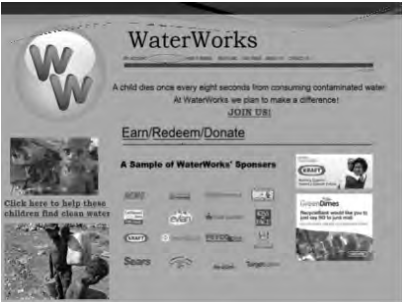

To get the WaterWorks program off the ground it will be prototyped in a relatively small town in New Jersey. The local municipality will be contacted to discuss the feasibility of starting an incentivized water conservation program. These savings will be used to pay for the contract with Recycle Bank to maintain a link to their website with points and donation links. Over the next five years WaterWorks will invite additional municipalities to

participate in the incentivized water conservation program.

A secondary outcome of the WaterWorks program is the raising of awareness about water conservation in the US and clean water needs in the developing world. This outcome can be measured by monitoring the percentage of municipal water consumers who participate in the water conservation program.

10. WATER = LIFE

By Brett Boye, Briana Graves, Iman Griffin, Kevin Machoka, Susan Moore, Thomas Pang, Ben Pullman, Alex Reiner, Ivan Serezhin

Strategic Summary: *Water = Life is focused on water poverty. Water is an essential part of life; one that is all too scarce for many people around the world. This group developed a plan to provide abundant, clean water to as many people as possible, relying on locally-devised and culturally-appropriate methods of storage and distribution that can be scaled up to meet the needs of individuals, small villages, towns, and cities.*

Present State of the Global Water System

- Of all water on earth, 97.5% is salt water, and the remaining 2.5% is fresh water. 70% of the fresh water is frozen in the polar icecaps. The remaining 30% is mostly present as soil moisture or lies in underground aquifers. *Less than 1% of the world's fresh water is readily accessible for direct human uses*¹
- More than half of the world's fresh water is found in Latin America (31%) and Asia (27%)
- An estimated *one billion* people worldwide have little or no access to clean water and 6,000 children die every day because of infections linked to unclean water, according to UNICEF²
- Most of those affected by lack of access to clean water live in Asia (550 million) and Sub-Saharan Africa (400 million). Asia is making progress toward improving these statistics, while Africa is *falling far short of the MDG target*³
- Lack of clean water for cooking and basic sanitary needs leads to disease and poor health
- Rural communities are 50% more likely than urban communities to lack basic sanitation
- Purification and desalination both require enormous energy inputs
- Agricultural processes account for 70% of fresh water use globally⁴
- In African and Asian regions where agriculture is the primary source of income, droughts are devastating to both human health and the economy
- According to a study conducted by the United States Department of Defense, dwindling supplies of fresh water and climate changes worldwide could fuel resource wars.⁵



The Lifestraw is an example of a simple, affordable, mass-produced solution to problems like the spread of water-borne diseases. Lifestraw uses a series of filters, iodine, and carbon to remove impurities and parasites from water.



The Q-Drum addresses the needs of people in less developed regions to transport water, often over long distances and rugged terrain in hot, dry weather. The Q-Drum reduces physical strain and prevents loss of water during travel using a unique design and durable materials.

Preferred State of the Global Water System

Affordable, clean, efficiently used and distributed water is available for all people.

This means:

- Reducing pollution to both freshwater and seawater worldwide. This will not only *improve potable water supplies*, but improve ecosystems as well
- Devise better water collection, storage, and distribution systems, especially in less developed regions
- *Utilize emerging, appropriate technologies* such as the Lifestraw and the Q-Drum that enable water to be purified and transported (respectively) at the source on a human scale
- Meet or exceed the World Health Organization's (WHO) minimum levels for the quantities of drinking water: *1 liter water/day for a 10 kg (20 lb) child 2 liter water/day for a 60 kg (130 lb) adult*
- Promoting local education initiatives focusing on daily water needs, disease prevention, storage and collection procedures, and water conservation.

How Do We Get There?

Water Collection Kit

- Each Kit will cost approximately \$100 retail and include: 1 Plastic 55 gallon barrel; 4 10 x 10 tarps; 32 3-foot PVC pipes; 4 filters; 4 flexible hoses; 1 bag heavy rubber bands; 4 PVC valves; 4 siphon pumps; 4 heavy duty plastic liners; 4 hollow cork stoppers
- The 55 gallon barrel will contain all the supplies needed for four 10x10 foot water collection and storage kits.

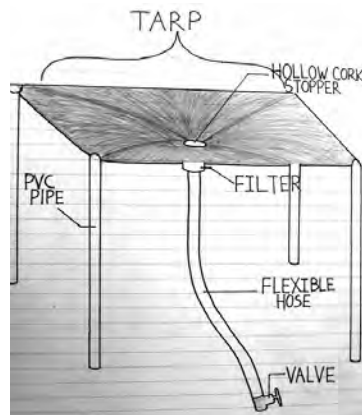

Short Term Goals

- Phase 1: Create and ship 1,250 water collection kits.
- Phase 2: Provide additional water for 5,000 people.
- Phase 3: Create a design solution for under \$100 per kit.

Long Term Goals

- Provide Irrigation kits for the pilot villages
- Build permanent storage systems (5th year)
- Add more sophisticated pumps (5th year) powered by solar or wind power
- Add composting toilet systems for additional water savings.

Collection

A kit containing a 10 x 10 foot tarp can collect enough water for approximately 100 days of personal use for one individual.

| Tarp Size (feet) | Potential Water Collected (gallons)* |
|------------------|--------------------------------------|
| 10 x 10 | 500 |

*for every 8 inches of rainfall

Storage

Trenches that hold water in large plastic bags are already being used in India. These containers hold 500 or 1000 liters of water and also serve to keep water cooler in hot summer months. This storage method could easily be used elsewhere.

Irrigation

- Any extra water collected can be used for drip irrigation in times of drought. This method of irrigation is extremely efficient and little water is wasted.
- The plastic tubing included with the kits is well-suited for drip irrigation

Human Resources Needed

- Start-up Phase
- Project Manager
- Communications Manager
- Deployment Phase
- Team of 6 trainers to teach initial set up and use on site



Example of
a small water
storage trench in
India



A simple drip
irrigation
system utilizing
components
similar to those
found in the kit

What Can Businesses and Individuals Do?

Funding Strategy:

- Form strategic partnerships with hardware stores (e.g. Home Depot) to provide free or discounted kit components
- Individuals shopping in these stores can provide a ‘physical donation’ (an actual component of the kit) and put it directly in the 55 gallon drum to be shipped out. This way, people feel a sense of ownership in the process and see exactly what they’re giving.

Project Summary

- The proposed design will provide water for 5000 people
- 1,250 Kits will be used to provide 2.5 million gallons of potable water for personal use
- The system will provide affordable, clean, efficiently used and distributed water by 2015.



11. INCREASING HOUSEHOLD WATER SECURITY

By Frances Brindle PhD and Ihsan Pashley

***Strategic Summary:** Tomorrow morning, 884 million people will wake up and the water they drink will be potentially lethal. Of these people, 746 million live in rural areas. Although these numbers are staggering, low cost methods for supplying and purifying water could reduce these numbers dramatically. The strategy described below addresses this dangerous water situation in rural areas with a three-faceted approach which targets: **improving the quality of drinking water, increasing water security by capturing and storing rainwater, and reusing/recycling greywater.** These three actions can dramatically reduce the shortage of clean and affordable water in the world.*



The Present State

Water is a precious resource with only a small percentage (less than 1%) of all the freshwater on Earth accessible for direct human use.¹ Because of this scarcity, the poorest are the ones who suffer most, with 884 million people relying on unimproved water sources from surface waters, lakes, rivers, and unprotected wells or springs, for all their water needs, as depicted in Figure 1.² These families are forced to spend a great deal of time and energy obtaining their daily supply of water and/or spending much of their income on this precious resource.

Figure 1: Present State of the Water Supply



The Preferred State

What’s missing is: readily available, quality drinking water; a water source which is more secure year round; and systems for reusing and recycling greywater. Our Preferred State provides for these needs, as depicted below.

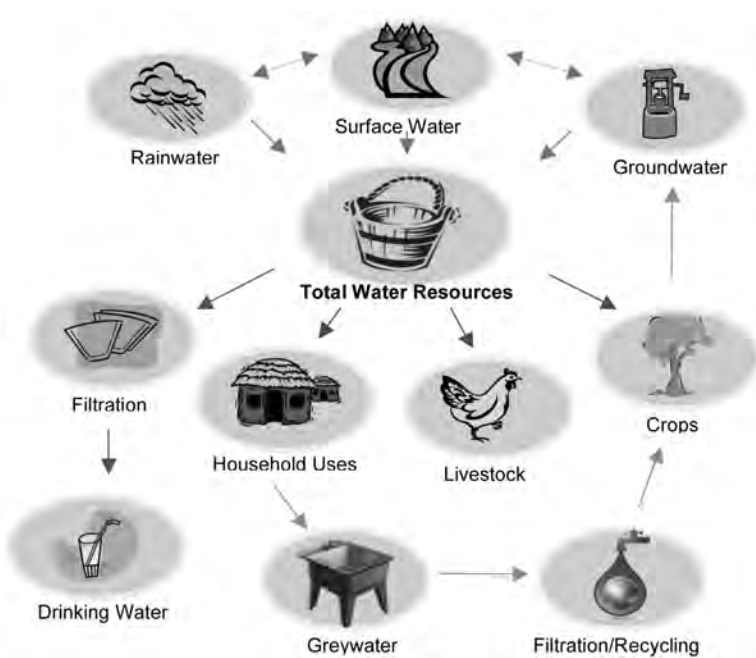

Figure 2: Preferred State of the Water Supply

Strategy

Part I – Increasing Water Quality: Drinking Water

Easily accessible, affordable, and quality drinking water brings many benefits. In addition to reducing illness from water-borne pathogens and injuries from hauling water, it has been proven to save money³, increase worker productivity, improve the quality of life, and free up time for productive work.



SODIS Method in use

Inexpensive quality drinking water can be made available by both ultraviolet irradiation and filtration.

- The **SODIS** (solar water disinfection) method is a virtually cost free method of water purification making use of the ultraviolet radiation from the sun. By simply placing a clear, label free, PET (Polyethylene terephthalate) bottle filled with clear water in direct sunlight for 6 hours, microorganisms are killed, thereby providing safe drinking water. *While this method is not recommended as a permanent solution*, and does not address water contaminants such as heavy metals, it can have an immediate impact on the quality of drinking water for everyone in sun-intense areas and/or seasons with minimal costs, until more sophisticated methods are available for use.⁴

The Filtrón Method

- The **Filtrón** water filtration method is a low cost household filter which treats bacteria-contaminated water making it safe to drink. This system can provide safe drinking water for an entire family for up to a year with an initial cost of \$10.00 per household and an additional investment of \$4.00 per year for a replacement filter (water turbidity directly affecting filter longevity). This system uses a filtering element which contains tiny pores that allow the water to pass through, but excludes bacteria, and is impregnated with colloidal silver to prevent bacterial growth. Additionally, the pot serves as a water reservoir to store clean drinking water. Another advantage to using this method is its ability to provide local industry. These units can be made by local potters after a short period of training, and are made using local materials without use of either electricity or advanced technology.⁵

Filtrón Unit



How Filtrón Works



Filtrón unit in use



Part II – Increasing Water Reserves: Rainwater Harvesting

On average, women and girls in developing countries walk 6 kilometers a day carrying 20 liters of water for their family, greatly reducing their time for other productive work and for girls to attend school.⁶ By supplementing the existing water supply through rainwater harvesting from rooftops, greater water stability and quality is assured and more time can be freed up for productive activities.

Rainwater harvesting can be accomplished by attaching bamboo or PVC gutters to catch water running off a roof, directing it to a holding tank, such as a water bladder or ferrocement cistern. This captured rainwater does not have to be treated and is safe for drinking.

- **Water Bladders** are relatively inexpensive, portable, and ready for immediate use. However, their manufacture does not provide for local industry.
- **Ferrocement Cisterns** are more expensive and permanent, but can be made locally from local materials after some training. Their manufacture can provide employment and a source of continued income.

Water Bladder
10,000L — \$73

Ferrocement Cisterns
10,000L — \$200 160,000L — \$800



Part III – Reuse/Recycling of Greywater

Greywater is generated from household water use, such as bathing, dishwashing, and doing laundry. While it can become a health problem if left untreated, it is a valuable water resource. Making use of the natural microorganisms in well-mulched soil, greywater can be readily filtered to provide irrigation for fruit-bearing trees and in turn provide food and potential income for a family while returning the water to the natural hydrologic cycle.

Greywater Reuse Process



Two possible approaches:

- An open system, as shown below, consists of a bamboo or PVC pipe with holes drilled into the sides, inserted into the ground next to each seedling tree. Collected greywater is then poured into the pipe.
- A closed system, as shown far right, is an alternate approach which allows for more automatic reuse of greywater. Attachment of a simple hose to the drain of a sink leads the greywater away and underground to a well-mulched garden planted with fruit trees.

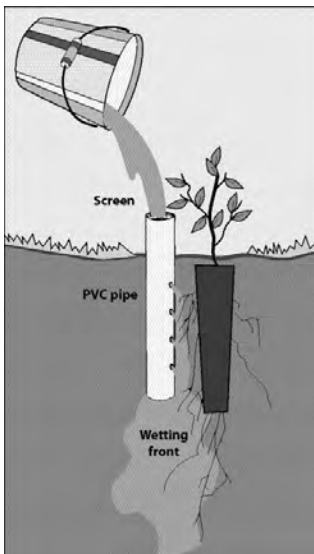

Open System

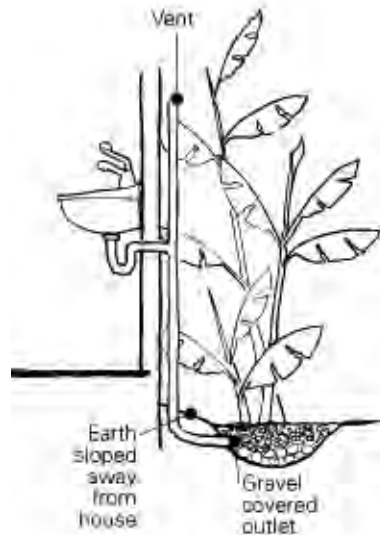

Closed System

Implementation and Next Steps

The plan we are proposing allows for flexibility. It can be applied in part or in whole, depending on the needs of the individual families, communities, or environments in Africa, Central America, and all other parts of the world where water is seasonal.

For example, in the African village of Murutunguru, on an island in Lake Victoria, a plan such as this would have a huge impact. The Filtrón System would gain easy acceptance and rainwater harvesting into ferrocement cisterns would provide water security during the dry season from mid-June until October.⁷

Another potential example is in Central America where in some rural areas of Nicaragua a rainwater harvesting system, together with a greywater harvesting irrigation system, would be most valuable.

The proposal can be accomplished by obtaining investments and partnering with local NGOs to disseminate information through public presentations and public service announcements, pamphlets and pictorial posters, manuals in native languages, text messages via mobile phones, and through the education system by training teachers to utilize these methods in school settings, allowing the children to be forces of change within the community.

Costs

Part 1: Quality Water

- SODIS (solar water disinfection) \$0 / household
- Filtrón \$10 / household and \$4 annually

Part 2: Rainwater Harvesting:

- Water Bladder 10,000L \$73/household
- (In time, this water bladder could be replaced by a cistern)
- Ferrocement Cistern 10,000L \$200/household

Part 3: Greywater Management:

- Bamboo and/or tubing minimal cost / household

Funding

Funds could be raised through a number of innovative approaches:

- “DIY” material suppliers in the developed world (such as Home Depot) could mount a funding campaign at point of purchase—thereby encouraging more affluent shoppers to purchase or contribute to the purchase of the necessary water harvesting and conserving equipment which would then be used in the developing world
- Micro-credit arrangements, with the community members providing the needed labor
- Government subsidy in the form of healthcare vouchers aimed at improving the health of rural populations.

Endnotes

Images

- 1 John Hopkins Bloomberg, School of Public Health: The Fabric of Public Health: <http://www.jhsph.edu/fabric-of-public-health/vision/>
- 2 SODIS: http://www.sodis.ch/methode/index_EN
- 3 SODIS: http://www.sodis.ch/methode/anwendung/index_EN
- 4 Patricia Foundation: <http://www.practicafoundation.nl/products/water-filters/ceramic-water-filter/>
- 5 Potters Without Borders: <http://potterswithoutborders.com/forum/?cat=11>
- 6 Engineers Without Borders – International: www.ewb-international.org/solutions0304.htm
- 7 DIY Trade: http://www.diytrade.com/china/4/products/5446846/water_bladder.html
- 8 RUCHI: <http://www.volunteer-ruchi.org/index.php?pageID=4&projectID=10>
- 9 Treehugger: <http://www.treehugger.com/2009/05/31-week/>
- 10 Roadside Revegetation: http://www.nativerevegetation.org/learn/manual/ch_10_4.aspx
- 11 Australia’s Guide to Environmentally Sustainable Homes—Technical Manual, design for Lifestyle and the Future: <http://www.yourhome.gov.au/technical/fs74.html>

Figures

- 1 and 2: Microsoft Word 2007 Clip Art

Endnotes

- 1 UN Water Statistics, Statistics: Graphs and Maps: http://www.unwater.org/statistics_res.html
- 2 John Hopkins Bloomberg, School of Public Health: The Fabric of Public Health: <http://www.jhsph.edu/fabric-of-public-health/vision/>
- 3 The United Nations World Water Development Report 3, Water in a Changing World, World Water Assessment Program, UN Water, 2009: http://www.unesco.org/water/wwap/wwdr/wwdr3/pdf/WWDR3_Facts_and_Figures.pdf
- 4 SODIS: http://www.sodis.ch/index_EN
- 5 Filtrón: <http://pottersforpeace.org/wp-content/uploads/ideass-brochure-english.pdf>
- 6 UNICEF, Water, Sanitation and Hygiene, Children and water: global statistics: http://www.unicef.org/wash/index_31600.html
- 7 Personal communication, Bartemelo Misano

12. SANITATION AND WASTE MANAGEMENT IN INFORMAL COMMUNITIES

DHARAVI, INDIA

By Aizaz Gill, Katrina Mattern, Rachel Zanders, Sheetal Akole and Eric Wu

Strategic Summary: *There are approximately one billion people living in slums around the globe. Even more alarming is the United Nation's estimation of that number growing to two billion by the year 2030.¹ Most of the inhabitants of these settlements do not have proper or safe sanitation and waste management services. Therefore, it is imperative to develop these services as soon as possible. The need for effective, safe and affordable sanitation and waste management in these informal communities is critical. Our strategy for meeting this need is to use a specific informal community, Dharavi, which is located in Mumbai, India, as our prototype and model for other communities throughout the world. The need is clear: in this informal community, there is only one toilet for every 1,440 residents, sanitation related illness and death runs rampant, most human waste goes into the local waterway "Mahim Creek" and most unrecyclable domestic waste is simply disposed of in the streets.*

Figure 1: Dharavi²

Introduction

Dharavi has a population of over one million people who live on a mere 550 acres of land.³ To put this into context, Central Park in New York City is approximately 843 acres, which means that over one million people live in an area smaller than Central



Park. As many as 18,000 people crowd into a single acre, which means that Dharavi is six times as populously dense as Manhattan. Despite the horrid living conditions this situation creates, the residents of Dharavi are a proud people who have often lived there for several generations.⁴ As a result, many have refused to relocate despite various government and private enterprise efforts.



Figure 2: Dharavi Land Area⁵ relation to Central Park.

In some ways Dharavi is a study of contrasts within India. On one hand, Dharavi is an informal community yet it possesses a unique economy. For instance, the residents of Dharavi manage to produce somewhere in the vicinity of \$600 million to \$1 billion every year.⁶ Unfortunately, that production comes at the cost of human misery as the workers often swelter in deplorable conditions. One example of this is a shop in Dharavi where twenty-two employees worked from 8am to 11pm. Those workers slept in the same cramped shop and began a new work cycle the next day.⁷

Dharavi represents a geographical contrast in the city of Mumbai as it is located right next to the Bandra Kurla complex, a commercial center which exemplifies the technological growth of modern India. The Bandra Kurla complex represents the rising economic power that India possesses while Dharavi represents the poverty which still plagues India. These two landmarks stand right next to each other in the largest city of India.⁸

There are a variety of factors contributing to the deplorable conditions in Dharavi. These include a lack of government recognition, awareness and finances.

Recognition

The informal community of Dharavi is not recognized by the government. The residents are seen as squatters, not legal residents. Therefore, the government provides no infrastructure. There is a lack of sanitation and no effective waste management system. Public services such as water, electricity, and sewage are not provided. The residents of Dharavi depend on a local mafia of sorts meet their many consumer needs.⁹

Awareness

An information gap also plays a part in Dharavi's conditions. There is a lack of education and awareness about sanitation issues, the connection between sanitation and illness and affordable alternatives.

Finances

Furthermore, there is a lack of finances needed to install proper infrastructure. It would be unfeasible to support a large, centralized waste management system, and so nothing is done. For this reason, our methodology fosters community involvement and bottom-up growth using initial financial stimulus from corporate, government, and NGO sponsors.

Preferred State

Our preferred state is to provide an affordable, safe, clean, effective, expandable and sustainable sanitation system, and a profitable, job-creating waste management system for Dharavi, India and then spread that prototype to other areas of the world.

Strategy

Stage One: Mapping Local Resources

Our strategy is modeled on a successfully implemented project within the informal communities of Chennai, a city located in the southern region of India.¹⁰ This project, known as the “Thideernagar Project”, has been successful due to the carefully detailed step-by-step strategies that specify the ways in which anticipated economic, social, and environmental growth are reached. Adapting this model to Dharavi, our strategy selects and tweaks various areas of this Chennai strategy in order to fit the larger, and more spread out Dharavi informal community. Mapping local resources is the first step. It is the basis of our strategy

to provide vital sanitation and waste reduction services to the people of Dharavi. One attraction of the mapping process is that it encourages participation and this strengthens the community. For example, when needing to locate areas of dense human and domestic waste, the people who live within the community will be able to pinpoint exact locations for waste eradication. This helps the waste removal process to be more efficient, and allows the community to exercise some form of control over its resources. This, in turn, helps the community to keep their territory clean and disease free.

Mapping local resources will also help in the process of locating community leaders. Community leaders are essential for motivating and educating the people that live within the community. Throughout the process of mapping the resources of the community, residents experience a sense of control and empowerment that aids in the growth and development of the community.

Using the results of the mapping process to locate the best sites, the next step is to provide one working latrine per 400 people. Among other things, this would result in a decline in the incidence of waterborne disease. The general target date for achieving this level of sanitation is the year 2016.

Waste management

In order to develop effective sanitation and waste management systems in informal communities such as that of Dharavi, India, the strategy deals with two different, but related, issues: domestic waste and human waste. Each waste stream is handled separately to provide the community with the most efficient and sustainable process.

To build a sustainable, resilient and expandable infrastructure, three important considerations need to be kept in mind when implementing domestic and human waste management systems. *First*, the project must be economically viable. There is already a uniquely vibrant economy existing in Dharavi.¹¹ Any design needs to foster the positive aspects of a community as it also lessens the impact of negative aspects. *Second*, the project needs to be culturally acceptable. This is an issue when dealing with human waste, as many cultures have their own reservations and beliefs about how waste products must be handled. Our strategy relies heavily on community involvement to make sure it has community buy-in. In order to provide for Dharavi residents, the project needs to draw advice and support from its residents. Mapping

allows the community members' input to have a direct effect. *Third*, the strategy needs to be environmentally friendly. It will be impossible for an environmentally degrading process to be successful in the long run.

Domestic Waste Management

To reach the preferred state with respect to domestic waste management, a system needs to collect trash from individual households, thereby preventing that trash from ending up in the streets or in Mahim Creek. The strategy we are proposing requires large amounts of community participation while simultaneously benefitting the community economically and environmentally.

Community participation begins with the previously mentioned community resources mapping process. By collecting information on community borders, resources, and problem spots leaders within each section of the community can be located. If empowered successfully, these leaders will establish a grassroots movement that will grow to encompass the whole community. The leaders are trained in the importance of sanitary conditions and the economic and other benefits of collecting trash in an organized manner. These leaders establish a community trash collection system. They reach out to other members of the community who are able to take up the position of trash collector. Once the trash collector has been educated by community leaders, their role is to travel from household to household, handing out two trash cans to each and extending their educational reach to the rest of the community. Part of the trash collector's duty is to explain that one trash can will be used to collect compostable material such as rotten vegetables or fruit peels while the other trash can is for any other recyclable waste such as plastics or paper. Trash collectors are paid a salary for the work they do. The money for this salary comes from a minimal (half rupee) service fee that is collected from each household every week. The service fee enables the building of waste management infrastructure to play a part in the local economy. It also encourages community members to take up the position of trash collector. By involving all members of the community in the sanitation system in various roles (whether that be the role of a leader, collector, or household member) the duration and effectiveness of the system is helped.

Separating wastes into compostable and recyclable is environmentally friendly. The compostable wastes can be used to create fertilizer for the benefit of the community, and in the case of crowded informal

communities such as Dharavi, can be sold for a profit. The recyclable wastes will be integrated into the existing Dharavi Recycling Compound. This is a sector of the community and local industry that sells recyclable material (including wood, plastic, scraps, and paper) to other processing plants in the city. In Dharavi, the residents can make about 14,000 rupees per day depending on the type and weight of material they sell.

Finances I

In order to ensure that this method of waste management remains sanitary, the community is provided with tools. Each household receives two trash bins to collect and separate their trash. Collectors require gloves, masks and carts to properly handle the wastes. An NGO and/or the government would need to jump-start the strategy by providing start-up financing. These resources would be used to purchase the necessary tools. Contributions are minimal: in the specific case of Dharavi, the needed investment would be approximately \$400,000. This would be enough to cover the wastes management needs of the entire one million people community. Residents would need to contribute \$30,000. The residents' fee converts to approximately two rupees per person in the community. This amount is an affordable, one-time fee for each resident of the community.

Human Waste Management

The preferred state will be reached by using two different systems of human waste management—a composting toilet and an anaerobic methane digester—both of which will utilize locally made separation toilets.¹²

As shown above, the toilet has a simple design. It is manufactured locally to stimulate the economy as well as provide for household human waste disposal needs. Decentralized separation toilets will be used to separate human waste into its separate components of solid fecal matter and urine. This separation is crucial as solid, dry



Figure 3: Locally made urination/defecation separation toilet (household scale)¹³

feces and urine (liquids) need to be totally distinct if they are to be processed to make fertilizer. Minimizing the contact of liquids and solids also eliminates the majority of foul odor typically associated with localized latrines.

The small, domed structure is a localized anaerobic methane digester. Essentially, this tank harvests the methane that occurs naturally in human feces to produce energy in the form of heat, electricity, or even cooking fuel.



Figure 4: Localized (self-sufficient and contained) anaerobic methane digester¹⁴

Finances II

The artifacts needed for implementing this phase of the strategy are compost toilets, methane digesters, carts for transporting solid waste, and dry material to be used in soaking up liquids from the latrines to promote dry composting.¹⁵

It will cost an estimated \$150,000 to install 2,500 toilets in Dharavi. The \$50 cost of manufacturing each toilet stays in Dharavi, as local pottery workers already have the skills and facilities to build such toilets. A \$10 labor cost of installation also is money that goes into the pockets of residents. Thereby the toilets have intrinsic value (sanitation) as well as an extrinsic value (economic stimulus).

Long-Term Management

The strategy has been designed so that it continues to be operational for the long term. It supports the community socially, environmentally and economically. It designed to be sustainable, and require little financial support in following years. In order to help the system grow and spread, it needs to develop and adapt to fit the community's needs. The community resource mapping process needs to be regularly updated to detect changes that help better target the community's resources. Outside

NGOs need to conduct regular reviews to ensure that the infrastructure has not been subjected to any form of corruption. Through these methods, implemented on a regular basis, the sustainability of the community's newly formed human and domestic waste management infrastructures can be guarded.

Conclusion

Dharavi has incredible potential and valuable resources that are waiting to be better harnessed. It is important to recognize is that our strategy does not impose a strategy on Dharavi residents but rather grows programs and fosters sustainability awareness. The methodology is bottom-up rather than top-down, which, if successful will foster self-reliance and a sustainable enterprise.

With continuous community resource mapping resulting in enhanced community awareness and empowerment, the strategy will be both flexible and powerful. Worldwide, many slums have similar characteristics to those found in Dharavi, thereby making this strategy of use around the planet.

Figure 5: Process Flow Chart

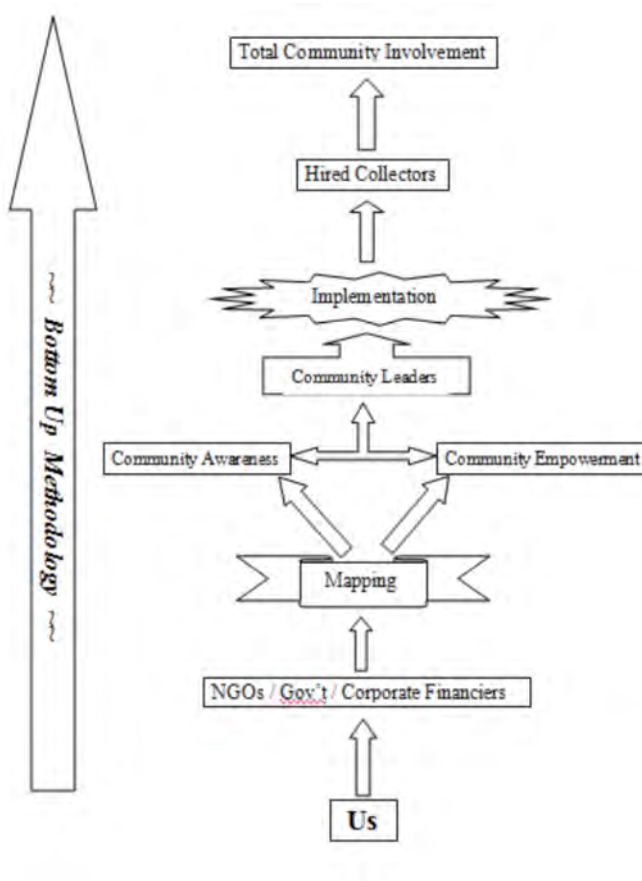

Works Cited

- 08, September. "Where Every Inch Counts." *Los Angeles Times*. Los Angeles Times, 08 Sept. 2008. Web. 17 Sept. 2012. <<http://articles.latimes.com/2008/sep/08/world/fg-dharavi8>>.
- Aroon, Preeti. "Photo Essay: India's Real-World Slumdogs." *Foreign Policy*. Foreign Policy Magazine, 4 Feb. 2009. Web. 17 Sept. 2012. <http://www.foreignpolicy.com/articles/2009/02/03/photo_essay_indias_real_world_slumdogs>.
- "Biogas." *Amm-mcrc.com*. Shri AMM Murugappa Chettiar Research Centre, 15 Mar. 2007. Web. 17 Sept. 2012. <<http://www.amm-mcrc.org/programmes/biotech/Biogas.html>>.
- "Dharavi Redevelopment Project." *Www.sra.gov.in*. Slum Rehabilitation Authority, n.d. Web. 17 Sept. 2012. <<http://www.sra.gov.in/htmlpages/Dharavi.htm>>.
- "Ecosan." *SOIL | Transforming Wastes into Resources in Haiti*. Sustainable Organic Integrated Livelihoods, n.d. Web. 17 Sept. 2012. <<http://www.oursoil.org/>>.
- "FAQ—Composting Toilet World." *FAQ—Composting Toilet World*. Envirolet, 2010. Web. 17 Sept. 2012. <<http://compostingtoilet.org/faq/index.php>>.
- Fulhage, Charles D., Dennis Sievers, and James R. Fischer. "Generating Methane Gas From Manure." *University of Missouri Extension*. University of Missouri, Oct. 1993. Web. 17 Sept. 2012. <<http://extension.missouri.edu/p/G1881>>.
- India. Thenmadurai Vattara Kalanjiam. Congressional Budget Office. *Implementation of Solid Waste Management System in Thideernagar Slum*. Chennai: CBO, 2007. Print.
- Ito, Ryusei, Hiroki Yamazaki, and Naoyuki Funamizu. *DEVELOPMENT OF LOW COST COMPOSTING TOILET FOR DEVELOPING COUNTRIES*. Tech. Hokkaido, Japan: Department of Environmental Engineering, Hokkaido University, 2007. Print.
- Jacobsen, Mark. "Dharavi: Mumbai's Shadow City." *National Geographic Magazine*. National Geographic Society, May 2007. Web. 16 Sept. 2012. <<http://ngm.nationalgeographic.com/2007/05/dharavi-mumbai-slum/jacobson-text/3>>.
- Kamath, Naresh. "More Stumbling Blocks for Dharavi Revamp." *BBC News*. BBC, 27 Jan. 2011. Web. 16 Sept. 2012. <http://news.bbc.co.uk/2/shared/spl/hi/world/06/dharavi_slum/html/dharavi_slum_intro.s tm>.
- "Life in a Slum." *BBC News*. BBC, 15 Aug. 2007. Web. 16 Sept. 2012. <http://news.bbc.co.uk/2/shared/spl/hi/world/06/dharavi_slum/html/dharavi_slum_intro.s tm>.
- "Quick Vital Stats on Dharavi." *Mumbai Matters*. N.p., 31 Aug. 2007. Web. 17 Sept. 2012. <<http://mumbaimatters.bombayaddict.com/2007/08/quick-vital-stats-on-dharavi.html>>.
- Reporting., Jim Yardley; Hari Kumar Contributed. "INDIA'S WAY; In One Slum, Misery, Work, Politics and Hope." *The New York Times*. The New York Times, 29 Dec. 2011. Web. 17 Sept. 2012. <http://www.nytimes.com/2011/12/29/world/asia/in-indian-slum-misery-work-politics-and-hope.html?_r=2>.
- Seale, Shelley. "How the Other Half Lives." *Worldpress.org*. Worldpress.org, 21 June 2007. Web. 16 Sept. 2012. <<http://www.worldpress.org/Asia/2831.cfm>>.
- "Twenty-First Session of the Governing Council Programme." *UN Habitat*. UN Habitat Features, Apr. 2007. Web. 16 Sept. 2012. <<http://www.unhabitat.org/>>.

Endnotes

- 1 “Twenty-First Session of the Governing Council Programme.” *UN Habitat*. UN Habitat Features, Apr. 2007. Web. 16 Sept. 2012. <<http://www.unhabitat.org/>>.
- 2 Aroon, Preeti. “Photo Essay: India’s Real-World Slumdogs.” *Foreign Policy*. Foreign Policy Magazine, 4 Feb. 2009. Web. 17 Sept. 2012. <http://www.foreignpolicy.com/articles/2009/02/03/photo_essay_indias_real_world_slumdogs>.
- 3 Kamath, Naresh. “More Stumbling Blocks for Dharavi Revamp.” *BBC News*. BBC, 27 Jan. 2011. Web. 16 Sept. 2012. <http://news.bbc.co.uk/2/shared/spl/hi/world/06/dharavi_slum/html/dharavi_slum_intro.stm>.
- 4 Jacobsen, Mark. “Dharavi: Mumbai’s Shadow City.” *National Geographic Magazine*. National Geographic Society, May 2007. Web. 16 Sept. 2012. <<http://ngm.nationalgeographic.com/2007/05/dharavi-mumbai-slum/jacobson-text/3>>.
- 5 Image courtesy of Google Maps
- 6 “Life in a Slum.” *BBC News*. BBC, 15 Aug. 2007. Web. 16 Sept. 2012. <http://news.bbc.co.uk/2/shared/spl/hi/world/06/dharavi_slum/html/dharavi_slum_intro.stm>.
- 7 08, September. “Where Every Inch Counts.” *Los Angeles Times*. Los Angeles Times, 08 Sept. 2008. Web. 17 Sept. 2012. <<http://articles.latimes.com/2008/sep/08/world/fg-dharavi8>>.
- 8 Reporting., Jim Yardley; Hari Kumar Contributed. “INDIA’S WAY; In One Slum, Misery, Work, Politics and Hope.” *The New York Times*. The New York Times, 29 Dec. 2011. Web. 17 Sept. 2012. <http://www.nytimes.com/2011/12/29/world/asia/in-indian-slum-misery-work-politics-and-hope.html?_r=2>.
- 9 Jacobsen, Mark. “Dharavi: Mumbai’s Shadow City.” *National Geographic Magazine*. National Geographic Society, May 2007. Web. 16 Sept. 2012. <<http://ngm.nationalgeographic.com/2007/05/dharavi-mumbai-slum/jacobson-text/3>>.
- 10 India. Thenmadurai Vattara Kalanjiam. Congressional Budget Office. *Implementation of Solid Waste Management System in Thideernagar Slum*. Chennai: CBO, 2007. Print.
- 11 Seale, Shelley. “How the Other Half Lives.” *Worldpress.org*. Worldpress.org, 21 June 2007. Web. 16 Sept. 2012. <<http://www.worldpress.org/Asia/2831.cfm>>.
- 12 “Ecosan.” *SOIL | Transforming Wastes into Resources in Haiti*. Sustainable Organic Integrated Livelihoods, n.d. Web. 17 Sept. 2012. <<http://www.oursoil.org/>>.
- 13 Photo Courtesy of Flickr.com
- 14 “Biogas.” *Amm-mcrc.com*. Shri AMM Murugappa Chettiar Research Centre, 15 Mar. 2007. Web. 17 Sept. 2012. <<http://www.amm-mcrc.org/programmes/biotech/Biogas.html>>.
- 15 “FAQ—Composting Toilet World.” *FAQ—Composting Toilet World*. Envirolet, 2010. Web. 17 Sept. 2012. <<http://compostingtoilet.org/faq/index.php>>.



STRATEGIC AREA III: GOVERNANCE

13. Subsidy Reduction

14. Land Reform: This Land is Our Land

15. Microfinance: Meeting the Demand

16. Food for Thought

13. SUBSIDY REDUCTION

By Sidharth Shah

Strategic Summary: *Increase food production, employment and wealth in developing regions through reducing subsidies to developed countries' farmers. Make developed countries' food systems stronger by removing subsidies.*

Introduction

International trade has enormous potential for reducing global poverty. For example, a 1% increase in the developing countries' share of world exports would lift 128 million people out of poverty.¹ The current global trading system discriminates against developing countries and hinders poor country participation in the global economy. Two of the biggest problems are agricultural subsidies in rich countries and lack of access by poor countries to international markets.

Agricultural subsidies are government payments or financial benefits (e.g. tax breaks) to farmers. Subsidies reduce the marginal cost of producing a crop for a farmer. Farmers therefore produce more crops and sell them at a lower price than without the subsidy. The lower price means that crops imported from poor states at the world market price cannot compete with the cheaper subsidized products in developed countries. Subsidized farmers produce more than the economically efficient quantity. They also often sell the surplus crop at cheap rates to other countries, a practice known as dumping. This means local farmers are able to sell fewer crops. Agricultural subsidies in wealthy states therefore have an adverse effect on the livelihood of farmers in developing countries as well as on the economy of these countries and, because the subsidies can put local farmers out of business, on the long term viability of local food systems.

The Extent of Agricultural Subsidies

Some brief statistics on farm subsidies:

- In 2003, the US subsidized agriculture by almost \$40 billion²; major subsidies went to cotton: \$3.9 billion in 2002³
- European Common Agricultural Policy (CAP) provided \$138 billion subsidies in 2003;⁴ \$9.7 billion EU sugar subsidies annually³³
- US exports cotton at 65% below production cost; EU exports

Decreasing Subsidies Over 10 years

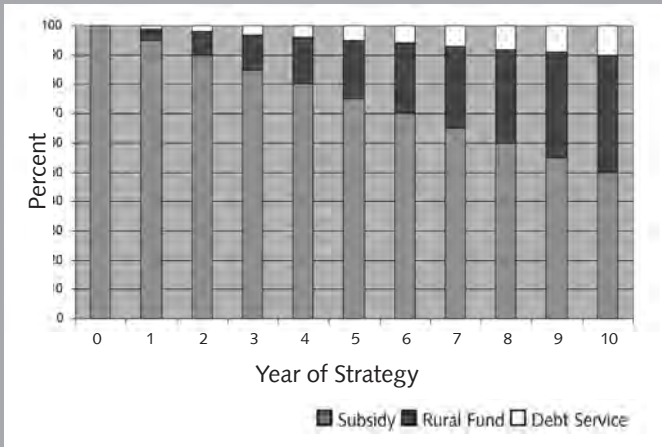

Decreasing Subsidies Over 20 years

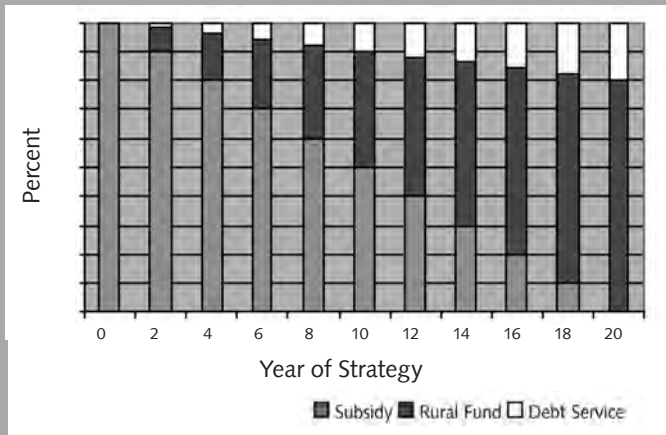

- sugar at 44% below normal market value⁵
- Approximate negative effect of U.S cotton subsidies in 2001–2002 on the GDP of selected African cotton producers:⁶
 - Burkina Faso—\$145 million
 - Mali—\$179 million
 - Benin—\$108 million

Goal

Halve the \$40 billion American and \$138 billion EU farm subsidies by 2015. Special emphasis should be placed on American cotton subsidies and EU sugar subsidies as these have the largest adverse effect on farmers in poor countries.

Strategy

The strategy requires a gradual diversion of money that is currently used for subsidies towards other forms of investment in rural communities in developed countries. Some money could also be used towards payments on national debt. Eighty percent would go back to farming communities and 20% would go towards debt payments.

Each year, less money is allocated as an agricultural subsidy and more towards investment in farm communities or debt payments. The objective is to demonstrate to farmers in developed countries that despite cutting subsidies, their government is committed to supporting rural communities. It should be explicitly advertised that money is not being taken away from citizens; rather, rural communities are being given the opportunity to reallocate funds towards other local needs. This will weaken the appeal of pro-subsidy groups as well as reducing public hostility towards freer trade in agriculture. Additionally, this program should alleviate some of the political “damage” that politicians are afraid of enduring if they cut subsidies, thereby encouraging more legislative decisiveness in reducing farm welfare.

The central government will lead this program, but local administrative authorities, including farmers’ councils, should be able to choose how to spend the redirected money allotted to a particular district. However, the central government should impose basic controls on how the money is spent to ensure that it is not used to directly or indirectly subsidize farming operations. For example, acceptable uses for the money could be to buy computers for local schools or to improve roads.

With the domestic political situation under control, the US and the EU should use the institutional framework of the WTO to multilaterally and simultaneously roll back subsidies. This would entail closing the various loopholes that allow for significant exemptions to anti-subsidy laws, such as the de minimis clause in the 1994 Agreement on Agriculture.⁷

Costs

Initial Zero, as current government spending is simply being redirected

Running A negligible sum that will be used to administer rural funds for redirected money

Sources A combination of central and local governments

Results

The halving of subsidies will mean that poor countries can sell their agricultural products on the world market at a fairer price. This will increase their GDP and the income of their farmers. This, in turn, will facilitate a long-term reduction in hunger, as more people will have the financial resources to buy food. The strategy will reduce the debt of the US and the EU. The reduction in subsidies will also force farms in developed countries to be more efficient in the crops they plant (they can only plant those in which they have a comparative advantage). A major non-tangible benefit is that farmers in developing countries will develop a sense of income security as their crops will have clear access to foreign markets.



Endnotes

- 1 UN Millennium Campaign: <http://www.millenniumcampaign.org/site/pp.asp?c=grKVL2NLE&b=1184423>
- 2 Oxfam briefing paper 76, “A Round for Free” http://www.oxfam.org.uk/what_we_do/issues/trade/bp76_modalities_and_dumping.htm
- 3 http://www.oxfam.org.uk/what_we_do/issues/trade/bp30_cotton.htm
- 4 Oxfam briefing paper 76. “A Round for Free”
- 5 Ibid
- 6 http://www.oxfam.org.uk/what_we_do/issues/trade/bp30_cotton.htm and CIA World Factbook
- 7 Oxfam Briefing Paper 76, “A Round for Free.” The de minimis clause allowed developed states to exempt a maximum of 5% of total agricultural output and a maximum 5% of subsidized products from a subsidy-reducing scheme known as the Amber Box. Developing states were permitted an exemption of up to 10% of agricultural output and up to 10% of subsidized products.

14. LAND REFORM

THIS LAND IS OUR LAND

By Kristina Mader

***Strategic Summary:** Increase food production and economic well being by increasing access to land ownership in developing countries.*

Introduction

It is vital for the rural and urban poor to own land in order to help them confront the challenges of the 21st century. Not only do property rights and access to land provide economic and social support for the rural and urban poor, but efficient and equitable laws are a key factor in allowing a country's citizens to experience a sense of security. This, in turn, helps increase production and standards of living.

A surprising number of people informally occupy land that technically or legally does not belong to them. This lack of land ownership undermines access to credit and other economic services. Having ownership of the land your family lives and works on is vital for economic security as well as social vitality.

Strategy: Land Policy Reform

Existing government land policies need to be transformed in many developing parts of the world. To facilitate this change, a new NGO, called the *Our Land* organization, would be funded at a scale that would enable it to undertake the changing of government land policy and to enforce existing policies so as to implement more equitable access to land.

This Land Policy Reform plan will take place over the next 10 years. The Our Land NGO would be funded from grants and partnerships with other organizations, as well as corporations. The Our Land organization would coordinate with governments at national and local levels to develop equitable, transparent, efficient, and culturally sensitive policies relating to land tenure. The success of these policies will be measured by the number of registration and ownership claims to land, as well as the increase in land value, which is a result of titling land.

The following is an explanation of the chart above. All the steps are overlapping.

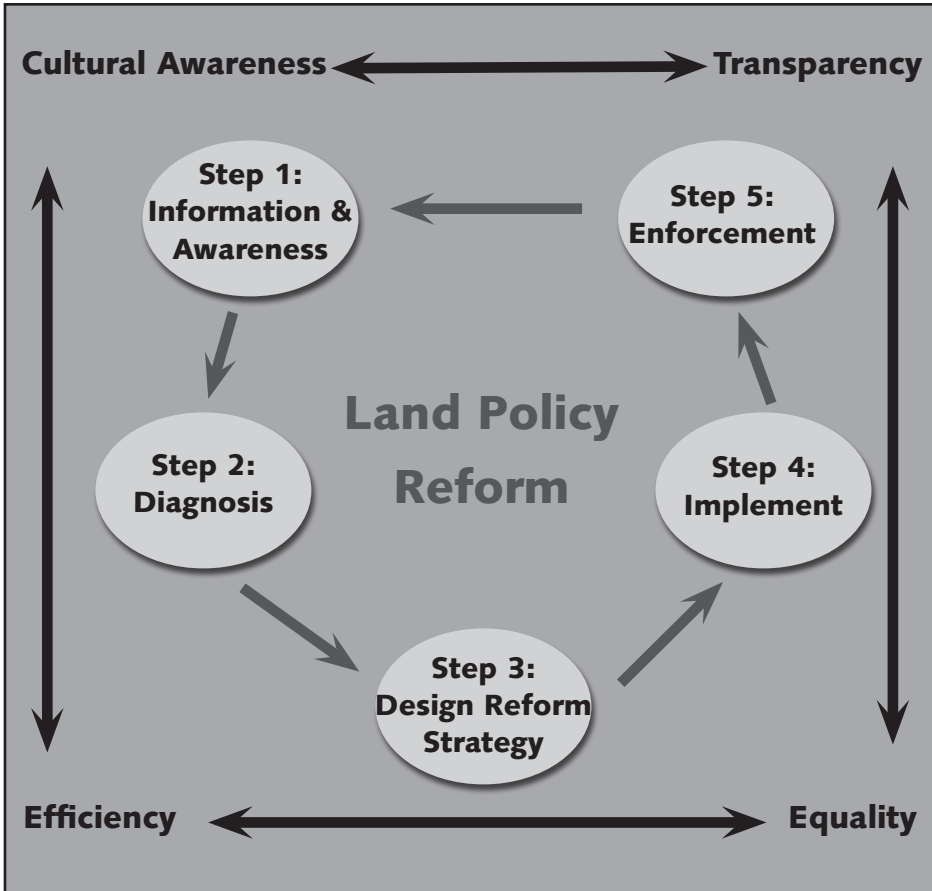

Step 1: Awareness and Information

This step is mostly informational. It includes making an economical case to governments that illustrates the benefits of land reform to everyone in their society. It would include how the plan should be implemented, its costs, and how it will benefit both the poorest people in the country as well as the entire society. This aspect of the program has four key issues: cultural awareness, efficiency, equality, and transparency.

Step 2: Diagnosis

This step analyzes data and discovers the problems and inequalities in the current land system in each country. Included in this step is collection of data on current ownership of land, both legally owned and

extra-legally “owned,” as well as accurate border maps. Environmental and geographic issues are identified, as well as any economic, cultural, and religious impacts on the system.

It is important to look at the historical reasons for the current land reform system but not to get bogged down in blaming people. Recognizing that there are historical inequalities and attempting to fix them in the present is key to being able to diagnose the country’s problems using a transparent process and to target them efficiently.

Step 3: Design Land Reform Strategy

Step 3 is to be completed within two years of starting the diagnosis process. The reforms created in this step shouldn’t necessarily completely overhaul current policies, but should reform problem areas, paying special attention to equality in distributive, inheritance, and ownership rights. Traditionally underrepresented groups, such as women, indigenous people, and the poor should be included equally. A process to collect and update land data, such as borders, ownership, etc. should be designed. This benefits the country as a whole, but also specifically this strategy, because it creates a base of information to use for enforcement. It is vital that this plan not be corrupted and care should be taken to maintain transparency through public access.

The process created to gain ownership must be cheap and fast, therefore encouraging the acquisition of rights. Local access should be emphasized for many reasons. Jobs created within the new sector will benefit the local economy. In addition, if the data is easily accessible to all, there will be a higher level of participation in rural areas which are key to the success of the program.

It is also important to remember to account for extra-legal land. Care must be taken so as not to punish current owners of illegal property, thereby discouraging legal registration. In this step, the strategy should also take into consideration any environmental, transportation, technological, educational, and communication reforms that need to be made so as to make this plan conducive to the country’s overall development.

Step 4: Implementation

This step is carried out by specific countries’ governments with the help of the Our Land NGO plus other civil society organizations that worked with the government from step one. This step will work only if effort is made by the country’s citizens and lawmakers to create or reform land laws.

In implementing the reforms, rural organizations and governments must be included. This will require better communication and transportation between organizations and regions. Most importantly, the implementation process must be culturally sensitive to each country's unique religious, ethnic, and cultural makeup.

Step 5: Enforcement

In the final step, followup of the progress of the reforms is ongoing. It signals the end of one stage of reform and the beginning of the next. Local agencies and organizations need to be made part of a mechanism that will allow reports of misuse or illegal acts regarding the new land policies. Whether the existing judicial infrastructure is used, or a new system is created, it is important that the process be transparent so as to allow the reforms to be their most effective.

Cost

The cost for this strategy varies widely from country to country, depending on how it is organized and the amount of reform necessary. The amount that current landowners are compensated will be the largest expense. This could be funded from the general budget or from a special tax on the revenues produced by the new owners of the land. If this strategy is integrated into the legislative agendas of each country, then the cost will be minimal, but the benefit to the government and its citizens from having millions of additional legal landowners will be immeasurable.

Conclusion

Through the hard work and dedication of those within each country, land ownership and use laws can be reformed. Ownership of land has proven to be an effective way to increase the economic well being of impoverished citizens in many areas around the world and will contribute to reaching the UN Sustainable Development Goal of halving poverty by 2015.

15. MICROFINANCE

MEETING THE DEMAND

By Meredith Aach

***Strategic Summary:** Increase availability of credit to new entrepreneurs; meeting the need for microfinance. Making small-scale loans available by greatly expanding resources of existing microfinance institutions.*

Introduction

The demand for microfinance has not been met due to the non-profit sector's lack of resources to finance it. Currently, it is estimated that 95% of the people who could use microfinance are not able to take advantage of this engine of economic development. Money allocated from the donor community to microfinance institutions around the world cannot fund enough loans to make a difference at the scale needed to radically improve the economic well being of the poorest segments of the global economy.

To meet this demand, the microfinancial system needs to be supported by for-profit institutions. The combination of investment from the for-profit community would be directed towards providing funds to offer credit and savings options to the economically active poor. The rest of the money given to these institutions by the donor community would be directed towards the extremely poor in terms of services (training and education).

One critique of microfinance claims that microfinance does not meet the credit needs of the poorest of the poor. This is because the extremely poor cannot take out a loan. It is generally believed that if these people were given a loan without any training or education, the loan might be spent on consumption. With more resources from the for-profit community to meet the demand for credit of the economically active poor, more funds could be made available for pre-loan services to those who cannot take out a loan.

Microfinance has proven to be one of the more efficient tools in the "toolbox" of development. It allows individuals and families in poverty to access financial services such as credit, savings, and insurance, which they would not have been able to do in a regular commercial bank because they generally lack collateral. With the met demand for microfinance being only about 5%, more innovative ways must be implemented to meet the demand for microfinance.

Goal

Expand microfinancial resources by at least an order of magnitude and encourage investment into existing microfinance institutions in order to meet the global demand for microfinance.

Strategy

Because the great demand for microfinance has not been met, microfinancial institutions need more resources to offer loans, services, and improve their present infrastructure. In order to do this, these institutions need to become sustainable institutions that can meet their costs (without support from NGOs, governments, or other donor agencies) through the efficiency of their financial transactions.

Many for-profit institutions feel the return is not high enough to loan out to so-called “high-risk” clients because they are poor. In fact, they have higher repayment rates than most clients in developed countries, especially in times of crisis. To increase incentives for microfinance, the strategy calls for:

- Increased transparency for all government and corporate transactions.
- Standardized financial reporting across all industries.
- Reduced transaction costs. Transaction costs of providing credit to the poor can be high due to the fact that there are many loans and they are small. Certain innovations, like a personal digital assistant (PDA) that is shared among microfinancial workers, can decrease these costs.
- Global information exchange for the microfinance industry.
- Reliable information marketplace to facilitate exchange of quality data. This will enable corporations to feel confident that they are getting true costs of transactions and repayment rates so they can decide whether their investments are profitable.
- Increased percent of financial expertise in the microfinance institutions. A large percentage of workers who work personally with clients is necessary because these workers increase social impact.
- Increased incentives for the commercial lending institutions to invest in microfinance (see chart). If commercial banks were guaranteed money if repayments rate were not up to “par,” there would be little to no down-side for these institutions to invest. Even though commercial banks are focused on increasing

shareholder value and returns on investment, improving their social image and the value of their brand will serve to help the company in the long-run.

Much of the current money for microfinance institutions comes from donor agencies, NGOs, and governments. If commercial banks and for-profit institutions invested money in microfinance institutions (which is becoming more widespread through socially responsible investing), resources of microfinancial institutions would increase substantially. The money invested in these institutions from for-profit institutions could be directed towards providing credit, savings, and insurance for the poor, while money donated from the non-profit community can be used for services like training and education.

The Microfinance Expansion Program

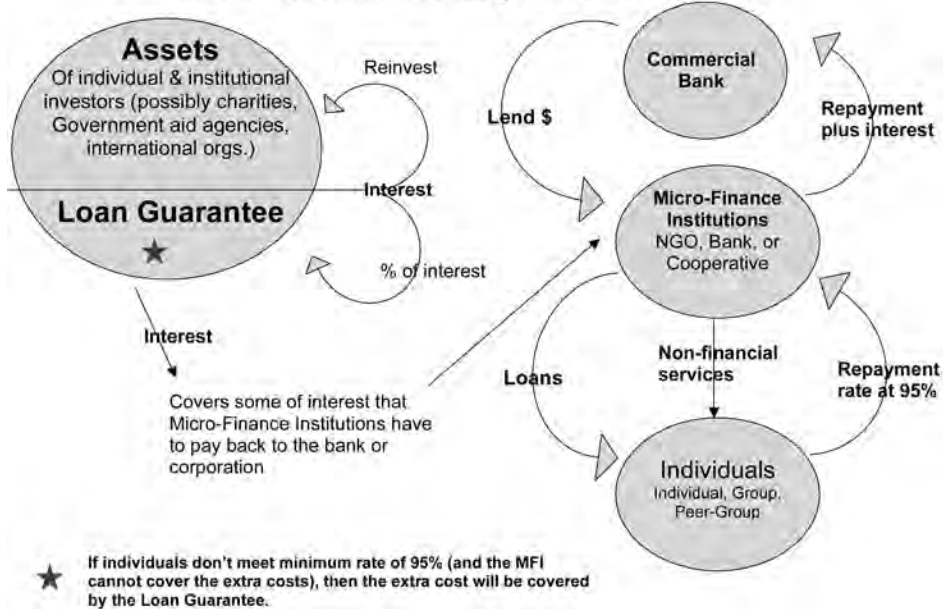

16. FOOD FOR THOUGHT

By Milly Barolette and Jennifer Bodenstab

Strategic Summary: *Increase food availability and decrease malnutrition in every food short region of the world by instituting school lunch programs; expand markets for local farmers while increasing school attendance, enrollment, and health of students.*

Introduction

Over 100 million school-age children do not attend school in the developing world. Many of these children are forced to drop out to earn money for their families so that food can be purchased. Some drop out because there is not enough food for them to eat, and attending school on an empty stomach is not viable.

Strategy

Feeding students while they are at school through a school lunch program will solve a number of problems as well as increase the capacity and well-being of the local economy. Students will be healthier as well as better students as they will not be distracted by hunger. Parents will have a strong incentive to send their children to school and the students will have an equally strong incentive to stay. In addition, local farmers and the local economy will benefit as farmers gain access to a reliable and steady market. The income they receive will cycle through the local economy as they purchase products with their new wealth.

Instituting school lunch programs in every school in food short regions of the world will go a long way towards eliminating hunger. This action will provide an important stimulus to the expansion of local commercial food markets by providing local farmers with an assured market for some of their crops, as well as improving the nutritional well-being of students. Markets for surplus crops are essential for providing incentives for local farmers to increase production. The added income from these markets will help reduce the level of poverty in rural regions and increase the capacity for further wealth generation. In addition to a school lunch program, hospitals, restaurants, and government offices could purchase additional surplus crops produced by local farmers. Such programs should have incentives so that small farmers have a competitive advantage in this budding market.



PART II

CLEAN
ENERGY
FOR ALL

CONTEXT/STATE OF THE WORLD ENERGY SYSTEM OVERVIEW AND PROBLEM STATE



The global energy system is characterized by the following:

- 6.8 billion people do not have access to an abundant, secure, clean, affordable, sustainable, energy supply
- 1.6 billion people do not have access to electricity, and 67% of these live in rural areas¹
 - Because the majority of the people who do not have access to electricity live in remote areas far from urban areas, connections to national grids to supply electricity are not the most practical or feasible way of providing access
- The current energy system pollutes the air, land, and water systems of the world
- Indoor air pollution kills 1.6 million people every year (four times the number of American deaths in WWII)
- 3 billion people are at risk from indoor stoves that burn biomass fuels² (WHO ranks indoor air pollution 8th among all environmental risks to human health). Women responsible for cooking and young children are most vulnerable
- Inefficient biomass fuels used for indoor stoves result in massive deforestation and cost families much of their income
- Having a clear vision of how things should be is essential for achieving that state. Having specific and measurable goals for the global energy system is critical for making those goals real.

Global Energy System Preferred State

The Global Solutions Lab's Energy Preferred State was developed from the values of the Lab's participants.

By 2030

20 years from the present, 100% of humanity has access to fuel,

electricity, and energy-related technologies that are:

- Sustainable
- Clean
- Ever-increasingly efficient
- Appropriately matched to local needs
- Affordable
- Abundant
- Reliable
- Adaptable
- Flexible
- Transparent
- Safe

- Secure
- Health promoting

The following are the major components of that vision:

- 100% of humanity's energy needs are met with safe, abundant, affordable energy supplies
- The production of energy is done in environmentally regenerative ways
- There is an ever increasing diversity of energy choices
- There is an ever increasing resource efficient energy system that is knowledge, rather than energy and materials, intensive
- There is ever increasing local self-reliance and global interdependence of our energy systems and sources
- National and local energy systems are subsidy-free and open-market based
- There are emergency backup systems and anticipatory crisis management systems in place
- Local and global energy systems are adaptable, flexible, and transparent
- Local and global energy systems are conflict free; energy is never used as a weapon or bargaining chip

- The global commons are managed for global wellbeing, not national, local or individual gain.

Eliminating energy shortages from the world, reaching the UN's Sustainable Development Goal for energy by 2030, and attaining the Global Energy System Preferred State from the previous page is a multi-dimensional and interrelated set of problems. Here are some of the broad brush-stroke actions needed:

To eliminate energy shortages and to ensure access to affordable, reliable, sustainable and modern energy, energy systems need to phase out carbon intensive energy sources and switch to renewable energy technology and sources. Investments are needed for:

- universal access to electricity and modern, clean cooking solutions in urban and rural areas
- increased power generation and transmission for industrial and other needs
- increased energy efficiency
- Increased energy research and development, aimed at increasing energy efficiency and decarbonization
- decarbonizing the energy system to keep the increase in global temperatures to less than 2°C above pre-industrial levels

The strategies that follow were designed to achieve the Sustainable Development Goals and the above Preferred State by 2030.

GLOBAL ENERGY STRATEGIES

**Sustainable Development Goal:
Affordable and Clean Energy**

**Global Solutions Lab Preferred State:
Eradicate* Energy Shortages completely
by 2030**

*Target: Reduce to zero, between 2020 and 2030, the number of people who suffer from energy shortages

Endnotes

- 1 http://hdr.undp.org/en/reports/global/hdr2007-2008/papers/gaye_amie.pdf
- 2 Ezzati, M., and D. M. Kammen.. “The health impacts of exposure to indoor air pollution from solid fuels in developing countries: knowledge, gaps, and data needs.” *Environmental Health Perspectives*. 2002



STRATEGIC AREA I: LOCAL ENERGY SYSTEMS

1. Powering the Future—Harvesting Human Mechanical Power/The Power of You
2. Improving Cooking in the Developing World
3. Electricity Rate Restructuring
4. Energy-In-A-Box
5. Green Energy: Recycling Waste from Thermal Energy Power Plants to Produce Biofuels
6. Urban Energy and Public Transit
7. Transition to Renewable Energy
8. Airvengers

“The green revolution is about how we produce abundant, cheap, clean, reliable electrons, which are the answer to the big problems we face in the world today. I would point to five problems, and they’re all related: Energy and resource supply and demand, petrodictatorship, climate change, biodiversity loss, and energy poverty. They all have one solution: abundant, cheap, clean, reliable electrons. The search for and the discovery of a source of those electrons is going to be the next great global industry. And I think the country that mounts a revolution to be the leader of that industry is going to be a country whose standard of living is going to improve, whose respect in the world is going to improve, whose air is going to improve, whose innovation is going to improve, and whose national security is going to improve.”

—Thomas Friedman

“If you don’t have a system, you don’t have a solution. Only a system will allow ordinary people to do extraordinary things. And if ordinary people can’t do extraordinary things, we have no chance to achieve the scale we need to address this problem.”

—Thomas Friedman

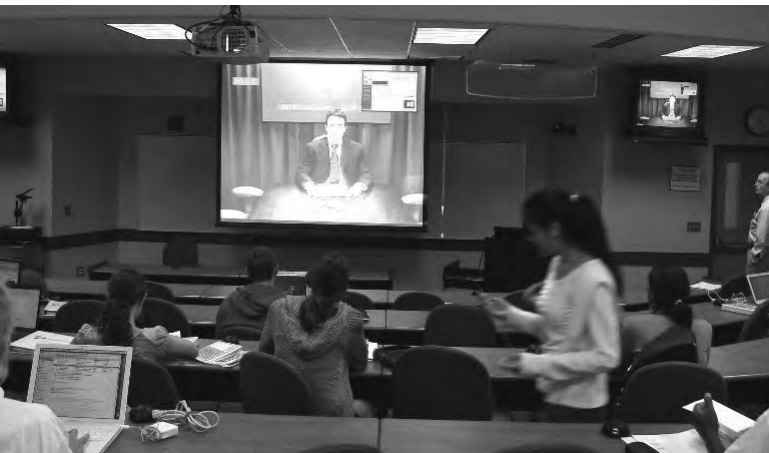

Teleconference briefing by UN officials.

1. POWERING THE FUTURE: HARVESTING HUMAN MECHANICAL POWER/ THE POWER OF YOU

By Komal Patel

Strategic Summary: *The human body has the capacity to generate useful amounts of energy in non-coercive, sustainable, and non-exhausting ways. Recent technology harnesses this power in ways that produce significant amounts of electricity that can power lighting and communications devices in areas of the world currently without any other reliable electricity supplies. This strategy shows that making high-tech devices that harvest human mechanical energy available to those who lack access to electricity holds enormous promise for meeting the electrical needs of individuals and families. Furthering development in rural areas by combining human energy harvesting and micro-finance techniques will increase the access to this form of electricity production.*

Introduction

People living in rural areas constitute nearly 80% of the 1.6 billion people without electricity in the world, and over 50% of these are small subsistence farmers.¹ Limiting factors for energy access and production for these people include no access to a national grid, little access to credit to put in place appropriate energy infrastructure, and lack of access to affordable energy supplies. *The Human Power:*

Electricity from Human Action Program proposes a creative strategy centered on some revolutionary new technology that harnesses the power of the human body.



Strategy

Decentralized methods of providing rural peoples with electricity need to be developed and implemented to improve the standard of living for rural people by providing them with a greater opportunity for communication and productivity. One method of

providing decentralized power to rural populations is to make available to them new technologies that harvest energy from human mechanical power that can then be used to power radios, flashlights, lights for home illumination during the night or to charge cell phones.

Biomechanical Energy Harvester

One of the newest technologies that captures energy from human mechanical power is a knee brace that converts power from muscles into electrical energy while a person walks.² The device uses a mechanism similar to that used by hybrid cars that recharge their batteries when the brakes are applied to the car.

The knee brace, called the *Biomechanical Energy Harvester*, was developed by scientists and weighs three and a half pounds. It generates up to 13 watts of power from each leg without requiring any additional human effort. Enough energy to power a cell phone for 30 minutes of talk time is generated for every minute of walking.³ Current estimates for the cost of the knee brace power pack are approximately \$1,000. It is estimated that with further development and mass production the price of the product will be able to be reduced to a more affordable rate that would make it a viable solution to providing electricity in rural areas.⁴ Additionally, the knee-brace is easily adaptable to an everyday life style, and it would also promote healthy living, as it is a means of exercise.

Adaptations of the *Biomechanical Energy Harvester* might also be developed for cattle and other animals, thereby greatly expanding the power available to rural families.

The *Pull-Cord Generator* weighs 14 oz. and has an average power output of 30 watts

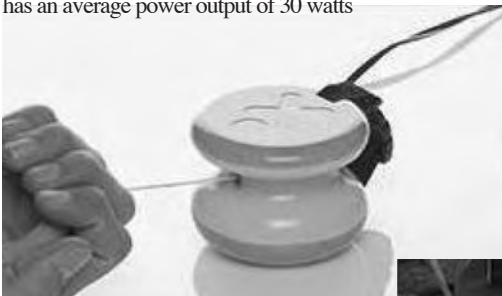

Pull-Cord Generator

Another piece of newly developed technology is the *Pull-Cord Generator* developed by Potenco Inc. The *Pull-Cord Generator* is a device that weighs 14 oz., has an average power output of 30 watts, and can produce enough energy to power a cell phone for 20 minutes of talk time, an iPod shuffle for 4 hours, or an hour of ultrabright-LED flashlight use with one minute of use.⁵ The device produces energy in a similar manner to hand-crank generators, but is much more efficient, compact, and portable.

The *Pull-Cord Generator* is not yet available on the market (as of late 2008) but field research is being done by introducing the product to rural communities in parts of Bangladesh, India, Africa, and Brazil.⁶ Potenco plans on partnering with the One Laptop Per Child program by providing a *Pull-Cord Generator* with each laptop so that children have a way to recharge their computers.⁷

The cost of the Pull Cord Generator is estimated to be between \$3 and \$5.

Suspended-Load Backpack

Another prospect for harvesting human mechanical energy is the *Suspended-Load Backpack* that generates power from the vertical oscillation of the pack that occurs while the person wearing it walks. Currently, the *Suspended-Load Backpack* requires loads between 40 and 80 pounds to generate a significant amount of energy and the marketing for these products is focused on soldiers and hikers.⁸ With further development, the *Suspended-Load Backpack* could be adapted to meet the needs of women in rural communities who carry their small children on their backs.

If the *Suspended-Load Backpack* could generate power with lighter weight loads and a safe carrier for children were created, rural women could

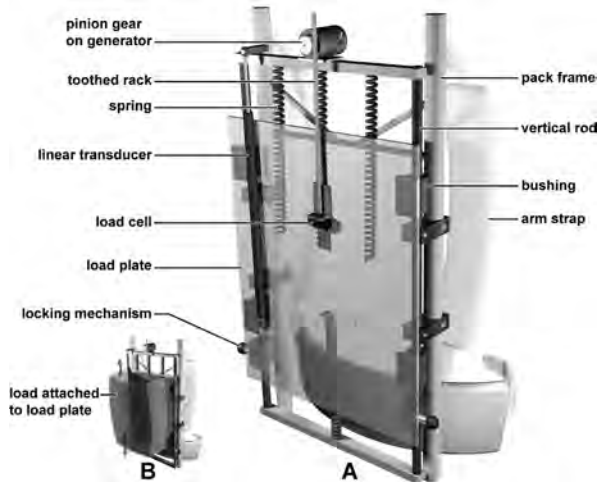

Baby carried on mother's back at the market in Chichicastenango, Guatemala, in a traditional backpack/sling.



produce electricity while carrying their children on their backs as they walk to perform their daily chores such as fetching firewood and water and walking to the market place.

MicroPower MicroLoan

In order to finance a project to give people in rural parts of developing nations access to devices that harvest human mechanical energy, a micro-finance scheme similar to that of the Grameen Bank in Bangladesh could be established to work specifically with the proposed technology. The basic framework of the *MicroPower MicroLoan* institution would be that small loans would be made to individuals in rural communities so that they could purchase either a *Biomechanical Energy Harvester* or *Pull-Cord Generator*. The individual who buys the device can then start a business by renting out the device to other members in the community who may need to harvest electricity to power their cell phones or the lighting in their homes. The income earned through the rental business would then be used to pay off the loan and additional earnings are kept as profits for the individual and their family, leading to an increased standard of living and development within the community.

Human Power: Electricity from Human Action

Financial Summary

Investment needed to reach ten million families with mass produced Pull-Cord Generator per year for ten years:

COSTS

YEAR 1

| | |
|---|--------------|
| Startup funding: | \$10,000,000 |
| Product (1 million units @ \$5 each): | \$5,000,000 |
| Business management/delivery logistics: | \$1,000,000 |

YEARS 2–10

| | |
|---|-------------------|
| Product (10 million units/year @ \$3 each): | \$30,000,000/year |
| Management/delivery logistics: | \$2,000,000/year |

INCOME**YEAR 1**

1 million units sold @ \$6.00 each: \$6,000,000

YEARS 2–10

10 million units sold @ \$4.00 each: \$40,000,000/year

Measurable Positive Results

After ten years, nearly 100 million families, approximately 500 million people, will have access to electricity for small-scale lighting, communication devices and battery recharging.

Conclusion

The *Human Power: Electricity from Human Action* strategy is an economically feasible way to directly target the energy needs of reaching the Sustainable Development Goals. It is a locally and globally viable strategy that is affordable and scalable. It can play an important part in reaching a future global preferred global energy system.



Endnotes

- 1 Elizabeth Becker, “Number of Hungry Rising, UN Report Says” *New York Times*, 12-8-04
- 2 J. M. Donelan, et. al., “Biomechanical Energy Harvesting: Generating Electricity During Walking with Minimal User Effort,” *Science*, Vol. 319, 2-8-2008 p. 807-809.
- 3 <http://news.bbc.co.uk/2/hi/technology/7226968.stm>
- 4 <http://blog.wired.com/wiredscience/2008/02/knee-brace-harv.html>
- 5 <http://www.potenco.com/whats-new/>
- 6 <http://www.potenco.com/products.html>
- 7 <http://blog.wired.com/gadgets/2007/09/potencos-yo-yo-.html>
- 8 <http://www.cnn.com/2005/TECH/09/09/backpack.power/>

2. IMPROVING COOKING IN THE DEVELOPING WORLD: A BLUEPRINT FOR A NEW COTTAGE INDUSTRY

By Kit Cali, Lauren Horneffer, Bartolomeo Misana, Michael Turri

Strategic Summary: One form of energy use that directly impacts the quality of life for everyone in the world is the energy we use to cook our food. In many parts of the developing world, the use of biomaterials such as wood and dung has large negative impacts on the health of families and the environment. There are current technologies that can replace existing inefficient and dangerously polluting cook stoves while also creating local industry and employment. This strategy shows how this can be done in three phases, leading to improved health, increased productivity and sustainable economic development.



Present State

Indoor air pollution kills 1.6 million people every year, primarily in the poorer parts of the developing world. There are more deaths each year from this cause than from AIDS. Three billion people are at risk from using biomass fuels in their indoor cooking stoves. In addition, the use of inefficient biomass fuels result in massive deforestation and cost families much of their time, income and health.

Many women and girls spend hours searching for firewood—which in some parts of the world exposes them to harassment, attack, rape or murder. There is also seriously damaging denudation of trees and other vegetation cover, which can, and has, led to soil erosion and desertification. And the problem is getting more serious as more

biomass is used for fuel, out stripping the environment's capacity for renewal, thereby leading to environmental destruction and longer and longer times to collect the firewood needed to cook food.

Overuse of biomass fuels for cooking also result in decreased animal grazing land; dry, dusty winds; and increased CO₂ emissions.

Preferred State

The Preferred State for developing country cooking stoves is a system that provides a convenient, affordable, clean, safe and easy way of cooking food in ways that are culturally appropriate and not damaging to the environment. For this to happen, the fuel source for cooking needs to be abundant, inexpensive, and usable by an efficient technology that is affordable. In addition, the preferred state for developing country cooking systems needs to be one that helps stop and then reverse desertification, does not increase the amount of CO₂ in the atmosphere nor produce indoor air pollution.

Strategy

East-African Cooking Technology¹

One technology that meets most of the above criteria, and would be a good transition to a solution that meets all the design goals of our preferred state, is the ceramic-metal jiko stove.

At the moment, 80% of urban families in East Africa use a traditional metal "jiko" charcoal stove. In rural families, 90% use a three-stone fireplace and wood stove. It is this technology that is doing the most damage to the most people's health and the surrounding environment.

The burning of wood is used for cooking, light and heat by 96% of the families in rural Tanzania, 90% of the families in rural Uganda, and 80% of the families in rural Kenya. An improved ceramic-metal jiko stove could reach all the families in these regions (and else where). One such stove is currently in limited use. Our strategy seeks to scale up and make its use pervasive.

Improved Ceramic-Metal Jiko²

This stove features an intuitive design derived from the familiar metal jiko. A single pot rests directly on the stovetop.

The familiarity of the design will help insure its rapid adoption. The

stove features an hourglass-shaped cladding manufactured locally from scrap metal and a perforated interior ceramic liner.

There is also a larger version—an institutional Jiko that incorporates a thin, insulating layer and a self-contained ash collection box.

Advantages of the ceramic-metal Jiko³

- Reduces charcoal use by 40%
- 50% more efficient
- Safer
- Affordable: domestic jiko sells for \$1–\$3 USD
(Fuel cost savings pay for jiko in two to three months)
- Fosters local economic growth (It can be fabricated locally from scrap and renewable materials—the ceramic parts can be made from readily available clay)
- Decreases cooking time (Boils water faster for longer)
- Durable; Lightweight: (3kg–6kg)
- High adoption rate: there are already 150,000 current users

Health benefits of the ceramic-metal Jiko

- Brings CO levels within WHO guidelines
- Substantially lowers airborne particulate matter

Environmental benefits

- Current users save 5,000 hectares of forest per year
- 100,000 tons of CO₂ emissions per year averted

Blueprint of a New Cottage Industry

There are four phases in our strategic plan for the development of a sustainable Ceramic-Metal Jiko stove cottage industry.

Phase 1: Increase Ceramic Jiko Adoption

Phase 1 introduces biomass briquettes to the target markets as a superior fuel source to the traditional use of gathered firewood. These biomass briquettes use agricultural and/or paper waste as feedstock. The resulting product is cheaper and cleaner burning. Its use will reduce deforestation.

The biomass briquettes burn 75% hotter than charcoal and are therefore more efficient and require less fuel. Two briquettes per person (250g briquette vs. 1.2kg charcoal) per day is needed to cook the average family's meals. Replacing charcoal and gathered wood with biomass briquettes will lead to the growth of a new cottage industry.

Traditional three-stone fireplace cooking



Above: Ceramic Jiko;
Above right: Ceramic-Metal Jiko;
Right: Old style metal Jiko



Production of
Ceramic-Metal Jiko

Ceramic-Metal Jiko

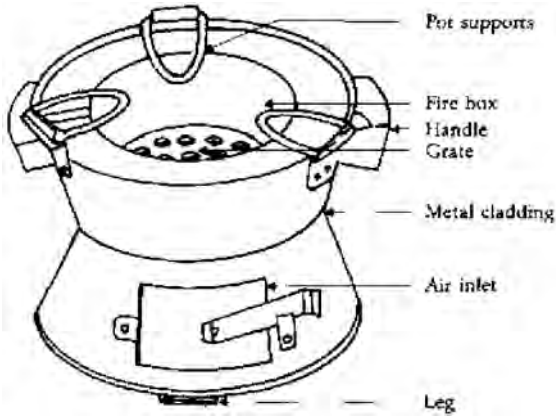

New Briquette Industry

The new cottage industry would be organized around the production of the biomass briquettes. Presses made from very simple, local parts are used for this operation. The basic fabrication process is clean and uses free or low-cost and renewable raw materials. A six-person team operates a single biomass briquette press. Such a press typically produces 750 to 1,000 briquettes per day—the amount needed to supply the daily fuel needs for 375 to 500 people.

Biomass Briquettes

Phase 2: Box-Type Solar Cooker

Phase 2 of the strategy features the introduction and widespread adoption of a box-type solar cooker. These solar cookers would supplement or replace the biomass briquette burning Ceramic-Metal Jikos when the sun was shining. This would reduce the emissions of CO₂ from the use of biomass briquettes.

The box-type solar cooker could be easily fabricated from jiko materials. It can easily reach 150°C (300°F) and so is therefore hot enough to cook any food. It is safe, and can allow unsupervised cooking, thereby allowing the food preparer to do other activities. The solar cooker requires minimal training to make it work effectively, can be used by a family or business, and can be used to pasteurize water or milk. And in combination with a Jiko stove, a family would be able to cook when the sun is not available, such as in the early morning, night, or when it is raining.

Phase 3: Scheffler Reflectors

Phase 3 of the strategy features the introduction and widespread adoption of Scheffler Reflector solar stoves. These solar powered stoves can be used indoors or out, and at times when the sun is not shining. Iron cylinders are used to store heat for night cooking.

There are a number of specialized designs of this type of stove. Most use simple materials and can be manufactured locally by a welder. They are ideal for large scale cooking such as is needed in institutions such as schools, hospitals and community center.

Phase 4: Community Solar Steam

Phase 4 of the strategy features the introduction and adoption of community solar steam plants that produce steam for electricity generation. The solar steam engine drives an electric generator that supplies the local area with electricity.

One solar steam engine currently in use is spreading throughout India. The Indian Ministry of Non-Conventional Energy is helping this happen. The device is popular for use in rural schools.

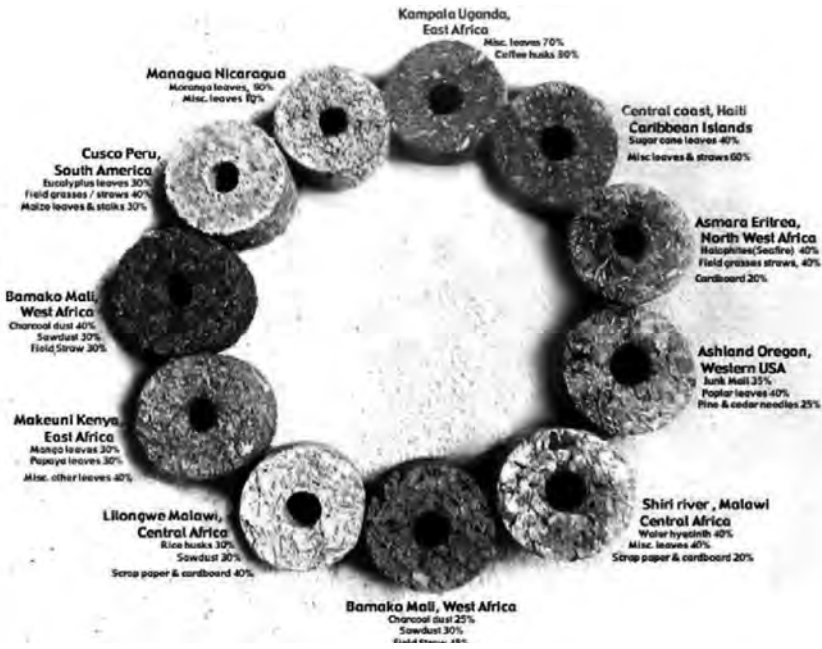

Solar steam power plant



Financing the Jiko System/Expanding/Bringing it to Scale

One way of generating the revenue needed to bring the Jiko cottage industry to scale is to generate funds by selling the Jiko stove in retail outlets in the developed world.

If a Jiko stove was sold for \$25 in US outlets like Home Depot or Target, it could generate enough funds to bring a new Jiko stove to four families in the developing world.

| | |
|----------------|--|
| \$ 2.50 | per jiko |
| \$ 2.50 | for shipping, packaging, etc. |
| \$ 5.00 | standard 100% profit to retailer partner |
| <u>\$15.00</u> | <u>tax-deductible donation</u> |
| \$25.00 | TOTAL |

This provides four stoves to needy families plus \$5.00 to the Solar/Steam Fund

Conclusion

The Improving Cooking in the Developing World: A Blueprint for a New Cottage Industry strategy is an economically feasible way to directly target the energy needs of reaching the Sustainable Development Goals. It is a locally and globally viable strategy that is affordable and scalable. It can play an important part in reaching a future global preferred energy system.

Endnotes

- 1 International Development Research Center “101 Technologies From The South, For The South” 1992
- 2 Ibid
- 3 EnterpriseWorks/VITA—Gyapa Charcoal and Wood Stoves Shell Foundation—Energy for Sustainable Development Journal

3. ELECTRICITY RATE RESTRUCTURING

By Dee Eggers, Alan Glines, Nancy Hodges, Janet Lowe, Stephanie Monson, Ari Zitin

Local energy strategies that could be implemented throughout the developed and developing world are needed if the world is to meet its energy needs in ways that do not undermine the planet's environment and climate.

One approach that the Global Solutions Lab took was that of the “stabilization wedges” described by Robert Socolow and S. Pacala of Princeton University.¹ This approach points out that “humanity already possesses the fundamental scientific, technical, and industrial know-how to solve the carbon and climate problem for the next half-century. A portfolio of technologies now exists to meet the world's energy needs over the next 50 years and limit atmospheric CO₂ to a trajectory that avoids a doubling of the preindustrial concentration and climate problem over the next half-century.” The Lab developed a local plan that goes down this path.

The wedge approach at the local level involved a series of actions. One was decreasing the reliance of electric utilities on fossil and nuclear fuels while increasing their use of renewable energy sources and energy conservation.

One way of doing this is to allow electric utilities to be in tune with undistorted market realities—rather than taking their cues from subsidized energy sources that lead to non-sustainable choices. One example of this is in Austin, Texas. Here, the local electric utility was allowed to offset new power plant construction by implementing energy conservation. It turned out to be far less expensive to save 1,000 MW of power through conservation and improvements in efficiency than it was to build a new power plant to meet peak load demands.

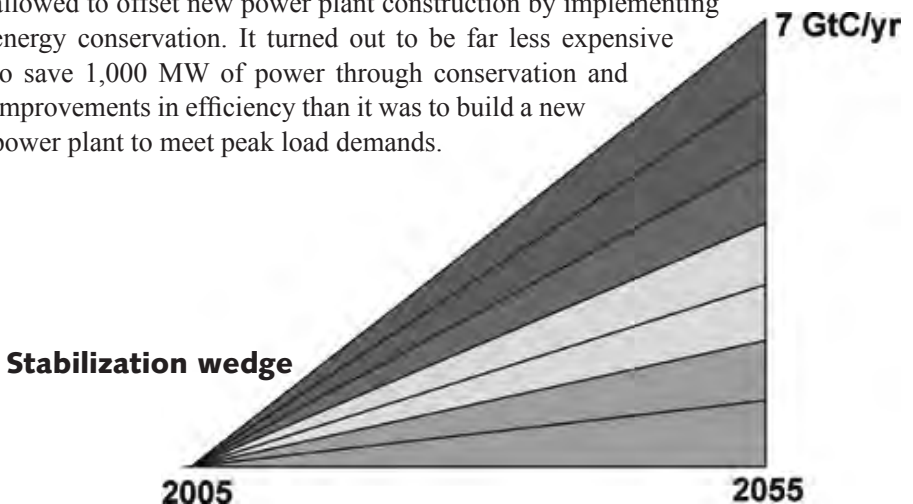

The utility implemented a rate structure that encouraged the driving down of peak use, and the use of conventional (fossil fuel) energy sources. New demand was, in effect, met with a “conservation power plant.” The results of this electricity rate restructuring included the avoidance of constructing an additional 600+ MW of electrical generating capacity. The utility also avoided over 50% of the cost of constructing a 600 MW power plant, as well as the pollution, health, and environmental effects that would have gone with it.

Austin’s utility was successful in doing this through a variety of actions and policies, including the encouragement of conservation, green buildings, district cooling, and education of the building trades (electricians, builders, plumbers, contractors).

If the US as a whole implemented the city of Austin’s energy program, it would, in 10 years, save over \$73 billion in electricity costs. Assuming half of this amount would run the conservation (and other) programs, there would be a net savings of approximately \$36 billion. Additional savings from avoided health care costs, improved crop yield, materials damage, etc., would also accrue.

Figure 1a. Historical carbon emissions with two potential pathways for the future

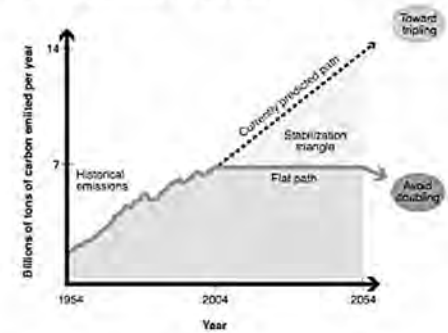

NOTE: Our currently predicted path (dashed black line) will probably lead to at least a tripling of atmospheric carbon dioxide (CO₂) relative to its preindustrial concentration, while keeping emissions flat (solid line) would put us on track to avoid a doubling of CO₂.

SOURCE: R. Socolow, R. Heitsch, J. B. Greenblatt, and S. Pacala.

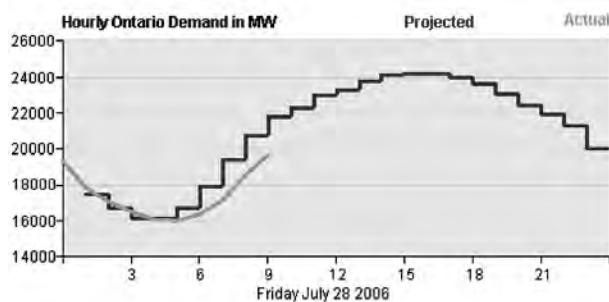

Note: Projected Ontario Demand uses a step graph to show the highest expected demand within the hour. Actual Demand uses a line graph to show average demand for that hour.²

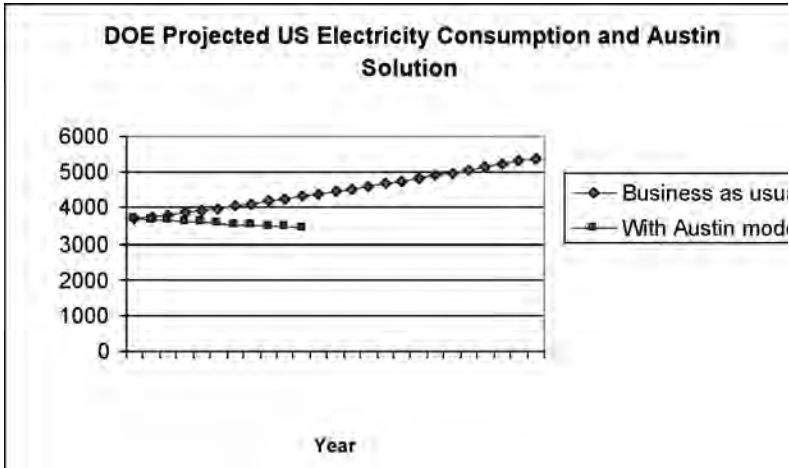

On a local level, for example in North Carolina, if the Austin energy program was implemented, it would result in the avoidance of building 9,000 MW of new power plants (about five coal and three nuclear plants) over the next ten years (saving over \$5 billion in plant construction alone). The net savings to rate payers in North Carolina would be \$2.5 billion. The return on investment for programs of this kind is substantial and rapid: most of Austin's energy projects paid back their initial costs in one to three years. Some of the projects took longer—but all were eight years or less. The return on investment in the form of decreased electricity costs makes these programs generate a net profit for the ratepayers quickly.

Endnotes

- 1 S. Pacala^{1*} and R. SocolowS. "Stabilization Wedges: Solving the Climate Problem for the Next 50 Years with Current Technologies." *Science*, August 13, 2004 Vol. 305.
- 2 IESO: http://www.theimo.com/imoweb/siteShared/demand_price.asp?sid=ic

4. ENERGY-IN-A-BOX

By Jonah Butcher, Peta Harrison

Energy-In-A-Box is a community education campaign that assists in baseline energy efficiency audits through providing the core essentials for increasing energy efficiency in the average dwelling. The “Box” contains all the ingredients and tools needed to implement the easiest energy efficiency improvements in all homes. Local home improvement suppliers would be one of the primary sponsors.

A demonstration project in the Asheville area of North Carolina has a target of reaching 10,000 homes in two years. 125 volunteers from surrounding colleges and technical schools, in partnership with local home improvement stores, will lead the effort. Savings of close to \$200/year per house (\$2 million total/year) are projected. Implementing the *Energy-In-A-Box* program in half of the households in the state could offset the need for a new coal fired power plant.

The Energy-In-A-Box kit includes:

- Four compact fluorescent light bulbs (which last more than ten times longer than incandescent bulbs and use a quarter of the electricity)
- Two bottles of non-toxic caulk and one caulk gun for sealing openings in walls, doors, or ceilings. Caulking is one of the easiest and most cost-effective means of reducing energy waste, allowing people to save up to 10–15% on heating and cooling costs annually
- One roll of weather-stripping tape for securing windows and exterior door frames from the elements. Drafty windows and door frames are one of the leading causes of unnecessary heating and cooling, and repairing this problem is quick, easy, and economical



- One surge protector to reduce phantom load or “vampire” power. This is the energy that is drained by electronics like televisions and computers even when they are not turned on. Plugging these electronics into a surge protector allows users to switch them all off easily, with the potential to reduce energy consumption by as much as 10–15%.



5. GREEN ENERGY

RECYCLING WASTE FROM THERMAL ENERGY POWER PLANTS TO PRODUCE BIOFUELS

By Katherine Tohanczyn and Sarah Raimondo

Strategic Summary: *Think Green. Think Algae.* Over the last one-hundred years, there has been a dangerous increase in carbon dioxide (CO₂) emissions into the atmosphere which is causing global warming. One of the main contributors of these emissions is the CO₂ released from the burning of fossil fuels in electric power plants and in transportation vehicles. The expanding use of biofuels, such as ethanol from crops, has been postulated as a help to mitigate fossil fuel caused environmental problems as well as to serve as a replacement for petroleum, whose natural supply is steadily decreasing. Biofuels derived from food crops have serious problems; biofuels derived from algae have several advantages that make them a greener fuel feedstock than crops like maize and wheat. Unlike conventional biofuels, algae can produce more fuel per area of land and can be grown on land that is not arable¹. If algae production facilities were retrofitted into existing coal and nuclear power plants, the use of waste energy, the recycling of water, and the selling of byproducts would lower environmental and economic costs of electricity production as well as provide increased employment.

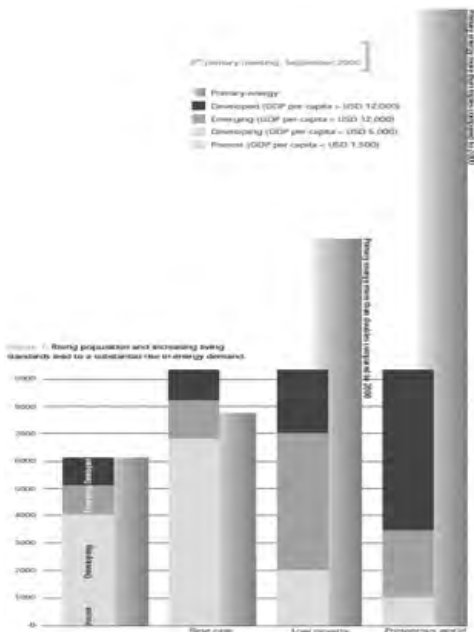

Introduction— Present State

Environmental Impacts: The Importance of Green Energy

The decline of the Earth’s environmental life-support systems can be seen in a number of ways, including increased air pollution, global warming, loss of biodiversity, quantities of waste, and inefficient land resource management. For ex-

ample, the environmental consequences of using oil include the impact from the searching, drilling, pumping, refining and transporting of oil to the end user who then emits CO₂ by burning it as fuel. In 2006, the world emitted a total of 11,219 million metric tons of carbon dioxide from the consumption of petroleum alone². This environmental impact, coupled with economic factors such as increased gas prices and military expenditures needed to secure reliable sources, not only affect the current state of the Earth but also its future.

Based on these issues, it becomes increasingly apparent that every country needs to cut down its dependence on fossil fuels and increase the resources used for developing alternative energy sources that are both cleaner and more efficient.

If we continue to use finite resources (such as petroleum) for energy, not only will the environment continue to deteriorate but we will also not be able to produce enough energy to meet the world's increasing demands. The figure below displays how an increase in population and living standards correlates to an increase need in energy.³ Ultimately, this rising energy demand will lead to increased competition for the world's dwindling reserves. Biomass, however, in particular algae, is a versatile and renewable resource that can fulfill a substantial amount of this growing demand.

Algae is a valuable resource for the living systems on the Earth, and can become one for industrial processes. Algae converts sunlight and carbon dioxide into oxygen. It is responsible for about 40 percent of the oxygen on Earth. Coupled with carbon-dioxide producing industrial processes, such as coal fired power plants, it could also be a major force in limiting our impacts on the atmosphere.

Preferred State

A preferred energy state to where the world is now, and towards which it is heading, consists of:

- Increasing the supply of energy that is both green, abundant and affordable
- Developing a viable, sustainable biofuel industry that enhances local, national and global energy security, provides environmental benefits, reduces global dependence on oil, and creates economic opportunities—all without infringing on food production capabilities

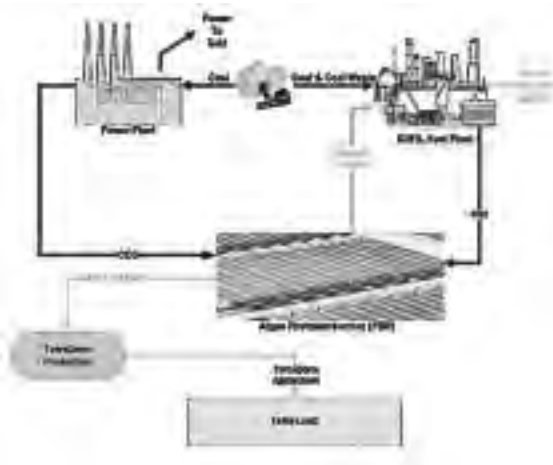

Figure 2: Source: <http://www.pottsmmerc.com/articles/2010/08/01/news/srv0000008941256.txt>

- Cost-effective production of electricity and biofuel achieved by utilizing waste heat from current thermal power plants as the energy feedstock for algae-producing facilities.

In order for this to be achieved, *Biosynergy Plants* (algae production / thermal power plant facilities) need to be implemented in all new thermal energy power plants in both developed and developing countries. In addition, *Biosynergy Plants* need to be aggressively retrofitted to all existing thermal power plants in the world.

Strategy

Our strategic plan calls for adding algae-producing facilities to existing nuclear and coal power plants. These new Biosynergy Plants would recycle water, waste heat, CO₂, and NO_x and turn them into biofuels produced from algae. In addition, the production of byproducts such as oxygen, hydrogen, fly ash, fertilizer, livestock feed, and aquaculture products would make these plants more productive and affordable by providing new resources, products and lowering the cost of production and maintenance of the facilities. For example, Hawaiian-based company BioEcoTek was able to lower the production costs of algae by retrofitting algae plants into existing wastewater systems through a combination of licensing, mergers, and acquisitions⁴.

There are over 2,700 power plants in the US⁵, and more than 50,000 in the world.⁶ Outfitting less than half of these with algae production facilities could produce enough barrels of oil to eliminate global gasoline consumption and significantly reduce oil consumption. One design being proposed for a Pennsylvania site will produce around 336,000 gallons of fuel per day (123 million/year).⁷ At \$3.00/gallon, that is \$370 million in sales per year—in just fuel sales. By-product sales will increase this revenue stream significantly.

Figure 2

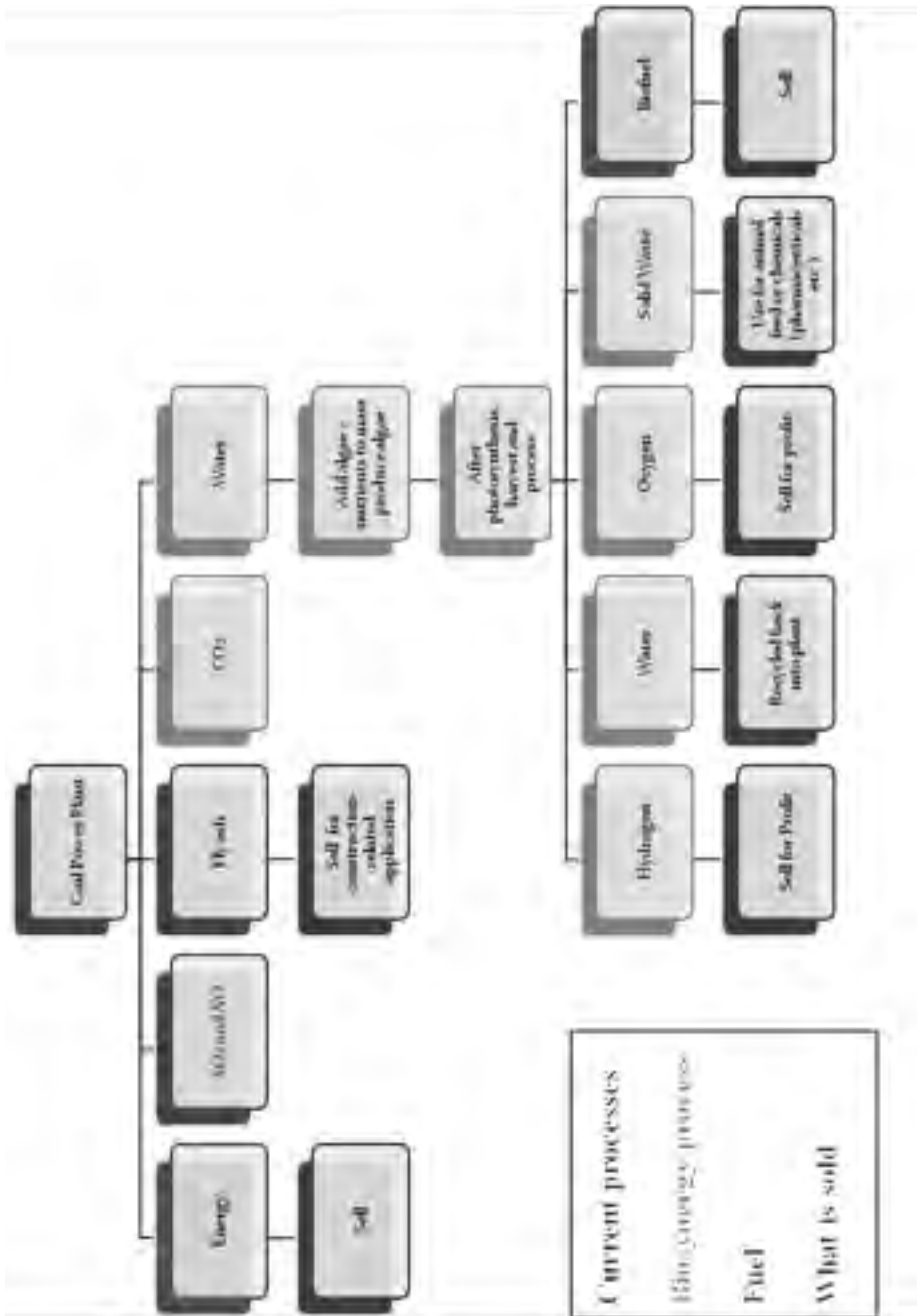
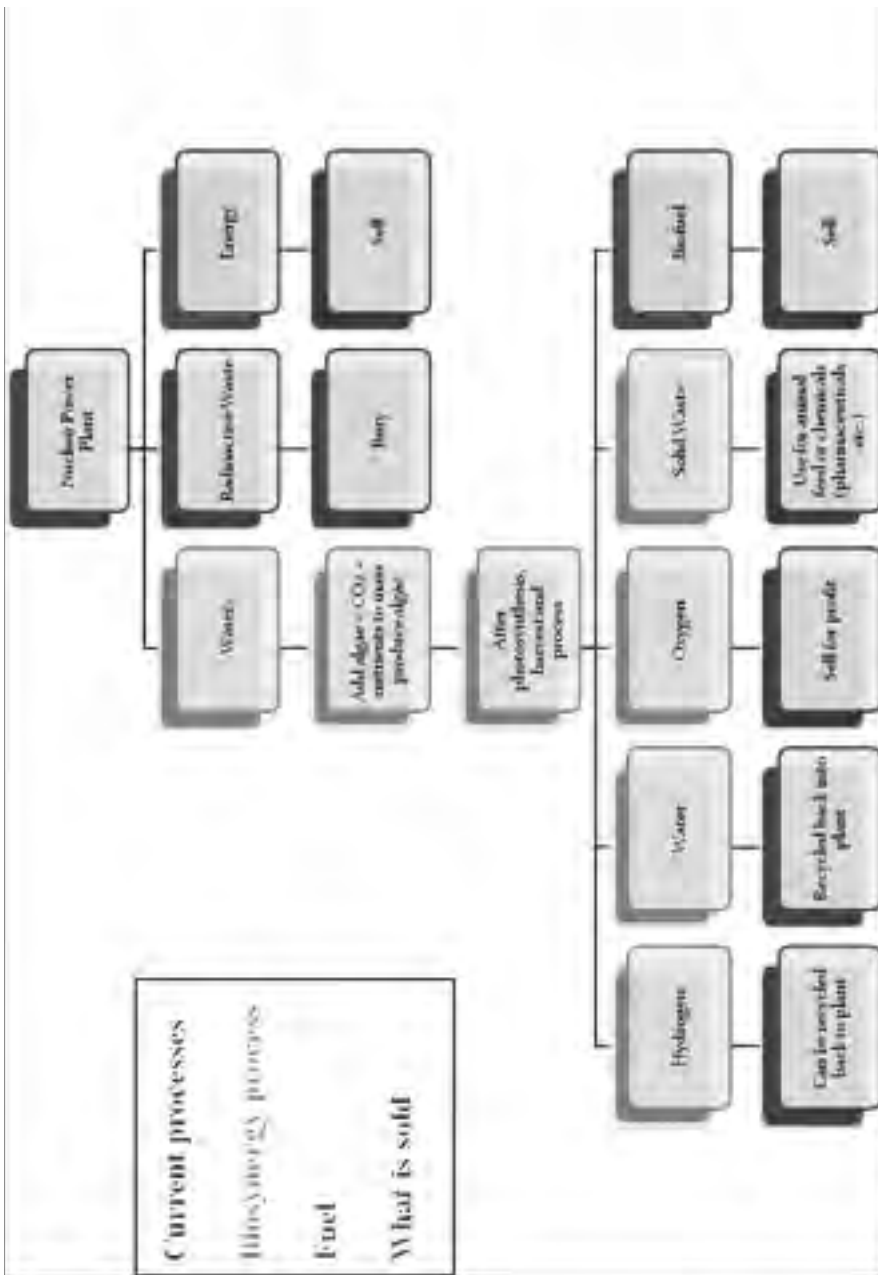

Figure 3



Yearly consumption of gasoline is around 142 billion gallons per year in the US.⁸ Twelve hundred of the above algae plants would produce over 147 billion gallons of fuel per year, more than matching total gasoline needs of the US.

Using a different algae production facility, Michael Briggs at the University of New Hampshire determined that 7.5 billion gallons of algae bio-diesel could be produced on roughly 500,000 acres (about 780 square miles). Using these numbers as benchmarks, it can be determined that the US would need roughly 9.5 million acres of land on which to grow algae to replace the oil needed for ground transportation needs. 9.5 million acres is less than 3% of the 450 million acres of land now used to grow crops. Furthermore, algae can be grown vertically as well as horizontally, which allows for even more efficient use of land.

Dr. Briggs also provided an estimate of \$12,000 per hectare (\$4,860 per acre) for operating costs. This figure includes power consumption, labor, chemicals, and fixed capital costs. The annual operating costs for a 250-acre algae farm would be \$1.25 million.⁹ Extensive research continues to lower this cost. In addition, the creation of jobs, reduction in CO₂ and additional economic benefits makes such investments compelling. For example, research done by the company, Inventure, indicates that CO₂ sequestering plants could generate over \$350 million in gross revenue each year with an absorption rate 70%.¹⁰ Such a profit is possible since this process allows for CO₂ reduction mandates to be met and thus, eliminating the need for carbon credits. In addition, the sale of chemicals and biofuel from algae quickly cover the cost of the facilities.

The following figures (Figures 2 and 3) demonstrate coal and nuclear power plant resources and components and resulting biosynergies. Both types of power plants share the common factor of heated water in their production of electricity. This energy flow can be recycled and applied to the production of algae. This leads to a decrease in the amount of water that coal power plants take from rivers and re-dump after usage. In addition, the coal power plant emits CO₂, which is a valuable resource in the algae's photosynthetic process. All algae are photosynthetic organisms capable of harvesting solar energy and converting CO₂ and water into O₂ and macromolecules such as carbohydrates and lipids.¹¹ By feeding the CO₂ released from the coal power plant to the algae production facility, there is less pollution emitted and more algae created.

In a similar fashion, Figure 3 demonstrates the same process for the nuclear plant except instead of utilizing CO₂, waste heat energy

is converted and used in the growth and maintenance of the algae. The algae is then processed and results in the following end uses:

- biofuel/biodiesel
- renewable hydrocarbons
- Oxygen and Hydrogen
- alcohols
- biogas
- co-products such as: animal feed, fertilizers, industrial enzymes, bioplastics, etc.¹²

Why Algae Over Other Biofuels?

One only has to look at the recent BP oil spill in the Gulf of Mexico; or the destruction of wildlife and biodiversity, loss of fertile soil, and degradation of farmland cause by oil production in Nigeria; or the thin layer of oily film that covers the Caspian Sea—to realize that a new form of fuel is necessary. One new form of fuel that many are turning to is biofuels. The question then becomes, which is the best choice for the feedstock for biofuels? Examining production figures leads to algae. There are four reasons: algae is abundant, affordable, efficient, and sustainable.

Algae is better than first generation biofuels (such as corn) due to the fact that it does not reduce traditional food supplies and which has led to inflation in food prices in many parts of the world. In addition, it can be grown year round and at a faster pace than most feedstock. Finally, it produces between seven and thirty times more energy (or quantity of oil) per acre than the next best crop, the Chinese tallow tree.¹³

The synergy between algae and thermal plants works in a variety of ways depending on the configuration and type of power plant. Different configurations are a result of geographical variations and resource availability between the type of plant. These differences can have a considerable impact on reducing costs.

The optimal design for a Biosynergy Plant is for it to be constructed as near a CO₂-emitting plant as possible. Diverting CO₂ from power plants to algae could reduce emissions by as much as 85% according to a project done at the Massachusetts Institute of Technology in 2008.¹⁴ Availability, recycling, re-usage, and waste utilization of water will further contribute to the efficiency and functioning of the plants.

No Longer a Thing of the Future

Many people believe that research and technology for the use of algae to create fuel is years away. Recent developments in this field prove that this is not the case. Research has been conducted for years by many different organizations, including those in academia, national labs, and private industry. This work, and corporate investment, demonstrates that fuel derived from mass production of algae is economically viable with present day cutting edge technology. For even more biosynergies to be created, additional research and development needs to be conducted into additional by-products and efficiencies of scale.

The advancements in this area are also being put into practice in a number of countries. For example, in 2009, the American energy company, Sapphire Energy, created the first car to operate on algae-based biofuel known as Algaeus. A Toyota Prius Hybrid completed a 3,750-mile trip from San Francisco to New York City.¹⁵ That same year, Continental Airlines, in collaboration with CMF International and Honeywell's UOP, conducted a test flight of a Boeing 737 Next-Generation aircraft over the Gulf of Mexico using algae derived jet fuel. The airplane ran on a combination of algae biofuel and traditional jet fuel.¹⁶ In addition, the European Aeronautic Defence and Space Company flew a slightly modified Austro AE300 in June 2010 equipped with dual engines, one operating on standard jet fuel, the other using pure algae biofuel. The test flight proved not only that algae biofuel is more environmentally friendly but also that it is more efficient by using 1.5 fewer liters per hour for the same performance.¹⁷

Cost

Two of the main obstacles hindering the advancement of algae biofuels are the initial start-up costs of the algae plant and the power that is needed in harvesting, extracting, and maintaining the algae. In addition, other costs include water and fertilizers, as well as land prices.

It is important to note that both public and private sectors have been substantially increasing the amounts of their investments in algae fuel-producing capabilities. Improved biological productivity and fully integrated production systems could bring the cost down to a point where algal biofuels could compete with petroleum at approximately \$100 per barrel.¹⁸ Exxon Mobil and Synthetic Genomics have already

invested \$600 million in the production of algae-based biofuels and are expected to invest billions more to globally scale up the technology and bring it into commercial production.¹⁹

Funding

In addition to the Exxon investment, funds are also being invested through various government entities worldwide. The US Department of Energy (DOE) with the input of more than 200 scientists, engineers, industry representatives, research managers, and other stakeholders, is presently studying the state of technology for algae-based fuels at a commercial scale.²⁰ European Union subsidies have provided half of the funding for a project called MiSSiON (Microalgae Supported CO₂ Sequestration in Organic Chemicals and New Energy) started by Swedish energy group Vattenfall. In July 2010, Vattenfall launched a major project using algae to absorb greenhouse gas emissions from a coal-fired power plant in Eastern Germany.²¹

With their growing demand for energy, big emerging markets such as Brazil, India, China and Africa have also invested in algae and have used the global economic recession as a stepping stone to join in the market, attract capital, and scale up their enterprises in algae investments. This has included the dedicated research, development, collaboration and diversification needed to prepare for rapid, transitional changes in regulations, mandates, markets, technologies and subsidies.²² Funding for algae production has also been through the combination of university-industry partnerships. For example, the University of Toledo has created a pilot-scale facility which is part of a research project linking research capabilities of Ohio colleges, universities, and nonprofit research institutions with the needs of industry in the state.²³ This allows state businesses involved in the energy industry to collaborate and use the facility to conduct research, grow algae using different multiple growth systems, as well as to convert algae to fuel. The result is a collaborative effort to perfect algae growth and extraction at a reduced and affordable rate.

Achieving the Sustainable Development Goals

The development of an alternative energy source that is green, abundant and affordable can help countries achieve almost all of the Sustainable Development Goals (MDGs), especially eradicating poverty and sustaining the environment. More specifically, the use of Biosynergy Plants can help accomplish the first MDG by enhancing food security, increasing labor productivity and creating employment. Biofuels derived from algae/thermal

power plant combinations can help fulfill the MDG of environmental sustainability because they are more efficient and renewable.

Endnotes

- 1 Michael Gross. "Algal Biofuel Hopes". <http://www.cell.com/current-biology/fulltext/S0960-9822%2807%2902431-1>
- 2 <http://www.eia.gov/emeu/international/oilother.html>
- 3 World Business Council for Sustainable Development. Facts and Trends to 2050: Energy and Climate Change. www.wbcsd.org
- 4 "BioEcoTek Hawaii". <http://www.bioecotek.com/>.
- 5 www.eia.doe.gov/cneaf/electricity/ipp/html1/ippv1te1p1.html
- 6 Carbon Monitoring for Action <http://carma.org/>
- 7 Evan Brandt, "Berks lawmaker courts algae farms for Pennsylvania" *The Mercury*, Pottstown, PA Aug. 1, 2010 <http://www.pottsmmerc.com/articles/2010/08/01/news/srv0000008941256.txt>
- 8 US Energy Information Agency, http://tonto.eia.doe.gov/oog/info/twip/twip_gasoline.html#demand
- 9 <http://www.americanenergyindependence.com/algae farms.aspx>
- 10 http://www.inventurechem.com/co2_sequestering.html
- 11 http://www1.eere.energy.gov/biomass/pdfs/algal_biofuels_roadmap.pdf. pg. 11.
- 12 http://www1.eere.energy.gov/biomass/pdfs/algal_biofuels_roadmap.pdf. pg.v.
- 13 <http://www.wired.co.uk/news/archive/2010-06/30/algae-biodiesel>
- 14 "German Power Plant Testing CO2-scrubbing Algae". http://www.spacedaily.com/reports/German_power_plant_testing_CO2-scrubbing_algae_999.html.
- 15 <http://www.sapphireenergy.com/press-article/67367-algae-fueled-car-completes-3-750-mile-cross/22046-events>
- 16 http://www.boeing.com/aboutus/environment/environmental_report_09/inc/flash-2-3-1.html
- 17 http://www.avweb.com/avwebflash/news/algae_fuel_diamond_da42_berlin_efficient_202700-1.html
- 18 http://www1.eere.energy.gov/biomass/pdfs/algal_biofuels_roadmap.pdf. pg 104.
- 19 "Exxon Sinks \$600M Into Algae-Based Biofuels in Major Strategy Shift". *NYTimes*. July 14, 2009
- 20 http://www1.eere.energy.gov/biomass/pdfs/algal_biofuels_roadmap.pdf. pg i.
- 21 Ibid. "German Power Plant Testing".
- 22 "Algae Investment Trends & Advanced Biofuels Insight" By WILL THURMOND, Columnist, *Biofuels Digest* Monday, March 1, 2010.
- 23 <http://toledocatalyst.com/index.php/2010/06/ut-receives-grant-to-build-algae-biofuels-research-facility-at-scott-park-campus/>. "UT receives grant to build algae biofuels research facility at Scott Park Campus." By Innovation Enterprises, *The University Of Toledo*, June 29, 2010.

6. URBAN ENERGY AND PUBLIC TRANSIT

By Melissa Day, Christine Hebert, Tri Nguyen, Uyen Nguyen, Michael Smith

Strategic Summary: *High population density in cities means that energy usage is often more efficient per person than in sprawling suburban or rural environments. Urban transportation, however, is still a significant energy sink. Traffic congestion wastes time and fuel; the emissions also negatively impact human health and the environment. Streamlining public transportation and increasing ridership is therefore an important strategy for reducing a city's energy demand while increasing public health. This strategy proposes tactics that incentivize public transit.*

Introduction

Cities house over half the global population and have a profound effect on this planet. The 21 megacities in the world, each home to 10 million or more people, occupy only 2% of the Earth's surface but command 75% of the global energy demand¹. In the United States, a full quarter of all energy use derives from transportation². This is the second highest energy consumption sector after electricity generation and one in which large gains in efficiency are not only possible, but immediately technologically feasible. Transportation is therefore a smart area to target for cities looking to conserve their energy demand.

Problem and Present State

At its present state, urban transportation produces a number of undesired side effects, including increased emissions, reduced air quality and poor public health. Road transportation alone emitted 10.5% of the world's

greenhouse gases in 2005³. Besides contributing to climate change, emissions pose a risk to public health. Traffic congestion-related emissions in 83 U.S. cities caused approximately 4,000 premature deaths in 2000. During the same year, these communities paid an estimated \$60 billion in congested-



related cost of wasted time and fuel⁴.

One approach to dealing with these issues in an urban environment lies in effective public transportation systems. According to the American Public Transportation Association, residents that live closest to public transportation drive an average 4,400 fewer miles a year than those who do not live near bus or rail lines. This effectively reduces the nation's carbon emissions by 37 million metric tons a year, which is equivalent to the electric power used by 4.9 million households⁵.

While public transportation systems have the potential to dramatically reduce the harmful effects of private transportation, these systems must be designed carefully to achieve this potential. In *Why People Don't Use Mass Transit*, it is said "the only way to diminish reliance on the automobile is to create a mass transit system that is superior to the automobile by the standards of automobile users"⁶. In many cities, public transportation does not save enough time or money and is not as safe or dependable as private transportation. These factors must be addressed in order to design truly effective public transportation systems in urban environments.

Preferred State

The preferred state of urban transportation is one in which there is attractive, effective, clean, affordable and sustainable public transportation op-

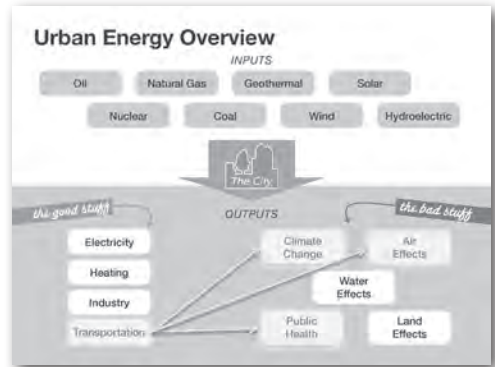

Present State: Energy and Transportation

Estimated U.S. Energy Use in 2009

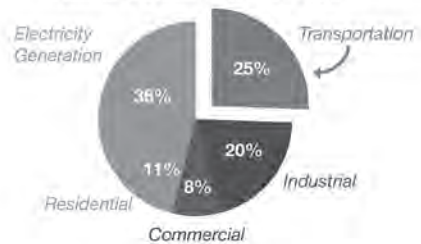

Present State: Health

In 83 U.S. cities, traffic congestion-related emissions caused about

4,000
premature deaths
in 2000.



Present State: Money

These communities paid an estimated
\$60 billion
in congested-related cost of
wasted time and fuel
during the same year.



tions that result in beautiful cities with high air quality, increased personal travel, and reduced traffic congestion, accidents and transportation-related public health incidents.

Strategy

To achieve the preferred state, this strategy calls for a public transit experience that is the most desirable transportation option. To provide a starting context, the public transportation system of Philadelphia, PA is used as a case study.

Based on research, the following set of goals were developed to accomplish the design challenge:

- A cost-effective, time-effective, dependable, and safe public transit system
- An attractive user experience
- Added incentives to ride.

System upgrades

The first two aspects of the overall strategy can best be addressed by minor system upgrades. A mass-transit system needs to be cost-competitive, dependable, timely, and safe. Analysis of the fee structure against other options (personal transit, bus, train, etc.) would be completed and

adjustments made accordingly. Routes should be re-evaluated based on the percent of the urban population living within walking distance of the stops, peak ridership congestion, adoption of routes and ease of transport to major sights and businesses. These routes should not require significant (>15 minute) wait times at peak travel hours. To minimize confusion, transit stations need clearly posted and understandable schedules and maps. Street corner stops need to be labeled with the associated bus lines. Incorporating a barcode option for smartphone users to look up more information would be implemented. Status indicators, including time to arrival and departure,

Present State: Philadelphia

Philadelphia, PA

- Population: 5.3 million
- Peak Travelers: 3.0 million

Congestion Costs Per Capita

- Annual Travel Delay: 39 hours
- Excess Fuel Consumed: 30 gallons
- Cost: \$919



Design Overview

End goal:

Reduce the number of cars in cities.

Design Challenge:

Create a public transit experience that is the most desirable option.

Case Study:

Philadelphia, PA

will be installed at major stops. Key routes will operate at all hours; if this is not possible, bike rental kiosks and a transit partnership with major taxi companies would reduce difficulty and increase ridership. Increased lighting, rules of conduct and law enforcement around transit sites and on the vehicles themselves will increase safety and perceived safety for riders. Finally, increasing the user experience of longer-haul transit options through comfort (spacious seating, work surfaces, privacy screens), amenities (wi-fi, outlets), and activities (texting games) will make transit more attractive. Implementation of these improvements will be split between retrofits and implementation of a newer fleet as old vehicles are aged out. Introducing energy-efficient vehicles will also increase the public's affinity towards the transit system.

Incentives Program

In addition to making bus rides an enjoyable and interactive experience, this strategy proposes three additional incentive programs to further persuade commuters, students and the general public that the public transportation system is superior to private transportation.

Since Philadelphia is a thriving metropolis with over 80 universities and higher education institutions and students that need to move around the city, one strategy is to work with these institutions to encourage students to leave their private transportation at home and rely solely on public transportation. Such a scheme has already been put in place by Ripon College⁷. In exchange for leaving their cars at home and pledging

Considered Design Interventions

■ *Dependability*

- More buses/trains
- Available GPS data for buses/trains
- Status indicators at stops
- 24-hour routes
- Taxi partnership



Considered Design Interventions

■ *Riding Experience*

| | | |
|-------------------------|-------------------|--------------------|
| Comfort: | Amenities: | Activities: |
| Spacious seating | TVs | Games |
| Tables/working surfaces | Wi-Fi | Exercise |
| Privacy screens | Outlets | |
| Refreshments | | |



ten hours of community service, Ripon students are rewarded with a free bicycle. Unlimited bus passes will also be incorporated in the Philadelphia program.

Concurrently, the strategy will work with businesses within Philadelphia to put in place incentives for public transit commuter programs for employees. In this way, businesses will subsidize public transportation to discourage congestion and eliminate unnecessary parking spaces⁸.

Finally, another incentives program will reward individuals for “good deeds.” For instance, doing things that benefit society, such as recycling or paying tickets on time, would be rewarded with free transportation tickets. This type of strategy has been used very effectively in Brazil⁹. Individuals will also be rewarded with subsidized public transportation if they trade in their private transportation vehicles, which would encourage people to move away from private vehicles more quickly.

Expected Benefits

The benefits of transitioning to a more comprehensive and sustainable transportation system are widespread. A safe and accessible transportation system that is appealing to all will greatly reduce the energy demanded by Philadelphia and ideally, after scaling to other cities, by the world in general. A society that is less reliant on private transportation will also decrease its air pollution and experience increased environmental health. In addition, the new and more expansive transportation system will greatly benefit Philadelphia’s economy. It has been estimated that for every dollar invested in public transportation, approximately four dollars are gained in economic returns¹⁰.

Furthermore, the incentives programs will not only encourage the use of the new and improved transportation system, but will have extensive social benefits. As citizens are rewarded for paying tickets on time and cleaning up the city, the city will become a more beautiful, healthy and efficient place to live. This buoys both property value and personal well-being – a win-win for the city and its occupants.

Implementation

The following timeline visualizes the proposed implementation. Over the first six months, the plan will secure funding and implement the systemic changes, including schedule and route adjustments. The incentive programs will also be tested during this time. Over the next

five years, the plan calls for the rebranding of SEPTA, Philadelphia’s primary public transportation provider. The goal is to remove the negative stigma attached to public transportation and encourage people to think of buses, trains and other public transit options in a more positive way.

Concurrent with the rebranding campaign, the strategy calls for the introduction of the new system. Rather than replacing the entire existing infrastructure in Philadelphia at once, the strategy will add an additional 300 energy-efficient buses to the current SEPTA system. It will replace old and inefficient buses with the most cost effective and environmentally friendly vehicles available. In the future, it will scale up to other cities, and eventually, reach a worldwide public transportation partnership. In this preferred state, private transportation will no longer be the most attractive option, and public transportation will be the preferred choice of the majority of all city residents.

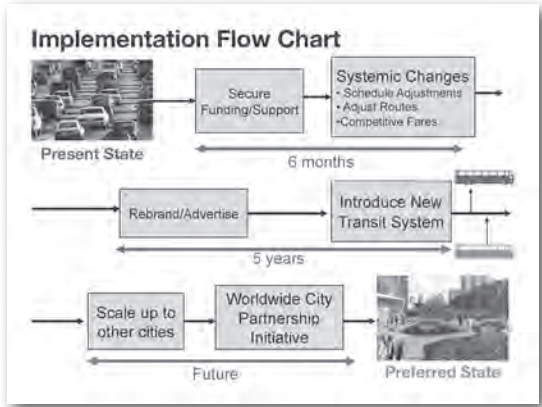

Costs of Implementation

There are a number of current options for new buses. The cost of the initial 300 buses called for by this strategy is revealing. The current cost of diesel buses, in comparison to hybrid buses and solar alternatives such as the Tindo bus being used in Adelaide, South Australia,¹¹ points to a number of options. With the 80% of the total cost covered by the Federal Transit Administration (FTA) and the 90% of the incremental cost of alternative fuel buses covered by the federal Clean Fuels Grant Program, the costs of hybrids or Tindo solar-electric buses as compared to

Bus Options

- Diesel buses*
• 300 buses = \$18 million
- Hybrid buses*
• 300 buses = \$25 million
- Tindo solar electric buses*
• 300 buses = \$36 million

Note: Philadelphia spends \$3.3 billion per year on congestion.

diesel buses are as follows: Currently, the city of Philadelphia spends \$3.3 billion annually on congestion alone¹². In comparison, the cost of this strategy scheme is minimal, given current subsidies for public transportation and for fuel-efficient transportation. A city that is less reliant on private transportation saves even further in terms of increased environmental health and decreased congestion.

Expenses and financing

SEPTA currently employs approximately 9,000 employees, has a fleet of 2,295 vehicles, and has a total operating cost of \$1.1 billion¹³. Including the cost for an extra 300 hybrid buses and an additional 600 drivers (assuming two shifts per day), in addition to a blanket 10% for system upgrades, the extra cost for this strategy would be approximately \$30 million if the least-cost diesel option is chosen.

This is a significant but not insurmountable sum. One way of raising some of the additional funds could be to form strategic partnerships with green businesses, or businesses looking to project their environmental stewardship to the community. Step one of this process would be to identify these businesses. Increased advertising revenue from additional bus sideboards and station space would be available. Once the system shows some success in terms of ridership, jobs created, and fewer cars and congestion, parking meter and lot fees could be increased for further revenue. This also serves as an incentive to consumers to continue their public transit ridership. Finally, if the United States enacted a \$19/ton CO₂ carbon tax, \$105 billion in revenue would be generated for green initiatives such as urban transportation¹⁴. Even if performed just at a local scale, this would be a major source of potential funding for transit initiatives. Pursuit of a combination of these options will result in funding for this strategy.

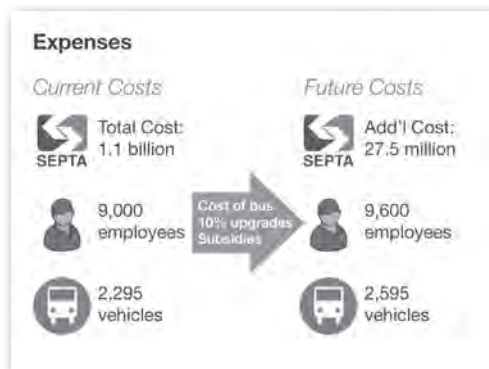

Conclusion

Urban public transportation is an investment in health and business. Fewer private vehicles leads to reduced air pollution, congestion, and energy waste. The ability to make public transit highly competitive has never been greater. A cost-effective, time-effective, dependable and safe public transportation is the key to increased ridership. Increased ridership is essential to making mass public transit sustainable. Providing an enhanced user experience, in addition to incentive programs, further aids the cause, costs the city very little and has significant returns.

Endnotes

- 1 Oliver, Rachel. All About: Cities and energy consumption. CNN.com, December 31, 2007. <http://edition.cnn.com/2007/TECH/12/31/eco.cities/index.html>
- 2 Estimated U.S. Energy Use Flowchart, Lawrence Livermore National Laboratory, DOE/EIA-0384 (2009), August 2010. https://flowcharts.llnl.gov/content/energy/energy_archive/energy_flow_2009/LLNL_US_Energy_Flow_2009.png
- 3 World Greenhouse Gas Emissions in 2005, World Resources Institute, http://www.wri.org/image/view/11147/_original
- 4 Levy, Jonathan; Buonocore, Jonathan; von Stacelberg, Katherine. The Public Health Cost of Traffic Congestion: A Health Risk Assessment. Harvard Center for Risk Analysis, Environmental Health 2010, 9:65. <http://www.transportationconstructioncoalition.org/Docs/TCC-Harvard-Traffic-Congestion-Report-Final.pdf>
- 5 Jones, Charisse. Transit systems travel 'green' track. USA Today, 5/8/2008. http://www.usatoday.com/news/nation/environment/2008-05-07-greentransit_N.htm
- 6 Dutch, Steven. Why People Don't Use Mass Transit. Created July 27, 2005. <http://www.uwgb.edu/dutchs/pseudosc/masstransit.htm>
- 7 College bike program entices new students to 'just say no' – to cars. Ripon College, February 12, 2008. http://www.ripon.edu/news/2007-08/velorution_021208.html
- 8 Conlin, Michelle. Suddenly, It's Cool to Take the Bus. Bloomberg Businessweek, April 23, 2008. http://www.businessweek.com/magazine/content/08_18/b4082000049320.htm
- 9 Interview with Jaime Lerner. SustainableCitiesCollective, March 7, 2011. <http://sustainablecitiescollective.com/dirt/21822/interview-jaime-lerner>
- 10 Facts at a Glance. American Public Transportation Association, ©2011. <http://www.publictransportation.org/news/facts>
- 11 Tindo: The World's First Solar Electric Bus. Adelaide City Council. http://www.adelaidecitycouncil.com/adccwr/publications/guides_factsheets/tindo_fact_sheet.pdf

- 12 Performance Measure Summary – Philadelphia PA-NY-DE-MD. Texas Transportation Institute, Texas A&M University (TAMU). http://mobility.tamu.edu/ums/congestion_data/tables/phila.pdf
- 13 Fiscal Year 2010 Operating Budget. SEPTA (Southeastern Pennsylvania Transportation Authority). <http://www.septa.org/reports/pdf/opbudget10.pdf>
- 14 Friday Infographic: Carbon Tax and the U.S. Federal Deficit. Weathervane, Resources for the Future. 5/20/2011. <http://www.rff.org/wv/archive/2011/5/20/friday-infographic-carbon-tax-and-the-u-s-federal-deficit.aspx>
- 15 Performance Measure Summary – Philadelphia PA-NY-DE-MD. Texas Transportation Institute, Texas A&M University (TAMU). http://mobility.tamu.edu/ums/congestion_data/tables/phila.pdf

7. TRANSITION TO RENEWABLE ENERGY

A global solution locally applied

by Ayuen G. Ajok (South Sudan), Rabia Sana (Pakistan), Anne Schiffer (Germany/ UK), Yosuke Tanabe (Japan)

Strategic Summary: *The global transition from a linear energy model of extraction, consumption and emissions to a regenerative or circular one relies on a complete switch to renewable energy sources. The team members chose their countries of origin, or ones with which they have significant experience, to develop local strategies for this global aim: South Sudan, Pakistan, The Gambia and Japan.*

This transition also requires a shift away from mono- and oligopolies of energy markets to empowerment of individual people and communities [1]. Therefore, the team decided to develop strategies from the bottom up, focusing on the individual and community level.

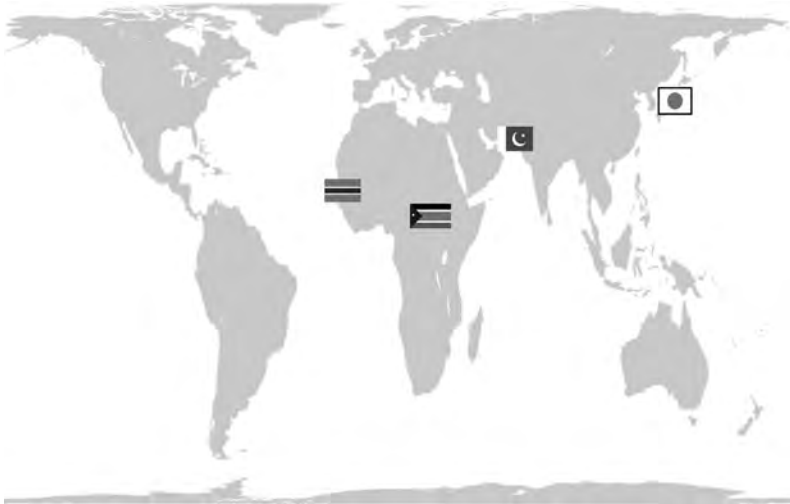

Peters projection highlighting the countries chosen for this project.²

Problem State

Globally, the majority of energy appropriated for human consumption is generated following a linear model that heavily relies on large scale



Global Problem State.^{3,4,5}

infrastructure and non-renewable fuels. Symptoms of this model include environmental degradation, climate change and fuel poverty.

The following section outlines the major energy challenges facing the specific contexts that were chosen by the team members.

South Sudan *by Ayuen G. Ajok*

The 22 year long civil war between north and south Sudan has left the newly founded country of South Sudan severely underdeveloped.⁶ Over the course of the conflict industries and infrastructure including entire road networks were destroyed and the country has so far not managed to rid itself of a chronic state of poverty.⁷

South Sudan is rich in oil resources but this has also led to an economic dependency on these: Ninety-eight percent of the country's revenue comes from oil exports.⁸

In the city of Juba, as in many cities across the country, the majority of electricity is produced by diesel generators [9]. Contradictory to the fact that South Sudan is rich in oil, the country has to import refined fuel which makes electricity production using generators very costly. In addition, this method is polluting to the environment and damaging to human health.¹⁰

Pakistan by *Rabia Sana*

Pakistan has been suffering from a severe energy crisis resulting in long hours of load shedding (power cuts) throughout the country. Compressed Natural Gas (CNG) filling stations remained closed for three days a week in Punjab Province which has had a significant impact on industries located in the region and the wider economy. Load shedding has resulted in violent riots throughout the country.

High dependence on aid from the World Bank and the International Monetary Fund (IMF) is causing inflation and increased energy prices. Furthermore, a general lack of energy supply including transport fuel and electricity is exacerbating the situation.¹¹

Approximately 81 percent of electricity production in Pakistan is based on oil and natural gas. The huge potential for renewable energy is currently totally ignored.¹²

The Gambia by *Anne Schiffer*

In this West African nation wood fuels still form the most important source of energy. The use of firewood and imported charcoal includes cooking, smoking fish and brewing Ataya, a local tea. A growing population is putting increasing pressure on these resources which are no longer regenerating as quickly as they are being depleted (pers. communication).

The country is increasingly dependent on imported fossil fuels for electricity generation and transport. Rising costs and unreliable or lack of electricity supply are exacerbated by a fast growing demand for electronic devices, particularly in the area of communications technologies.

Mass charging
of mobile
phones in
Gambian
village.¹³



Japan by *Yosuke Tanabe*

Ninety-six percent of primary energy resources consumed in Japan are imported.¹⁴ Nuclear power has been regarded as a major player to become more self-sufficient because uranium can be regarded as long lasting energy due to nuclear reprocessing technology.¹⁵ Amongst Japanese nuclear power enjoyed the reputation that it is cheap, reliable and safe. The Fukushima Daiichi nuclear disaster which was induced by an earthquake that measured magnitude 9.0 on the Richter scale, brought the flaws of nuclear power to the awareness of the Japanese. It revealed that the true cost should include protection against natural disasters and terrorism, disaster management, postdisaster recovery and the long-term management of radioactive waste. Following the explosion at Fukushima Daiichi 74% of people favoured a complete phasing out¹⁶ and 60,000 people demonstrated against nuclear power at a rally in Tokyo.¹⁷

Preferred State

The preferred global state of energy follows a regenerative or circular model inspired by nature. In this vision 100% of energy needs are met, energy is abundant and affordable, all solutions rely on renewable energy sources and a global state of energy justice is reached.

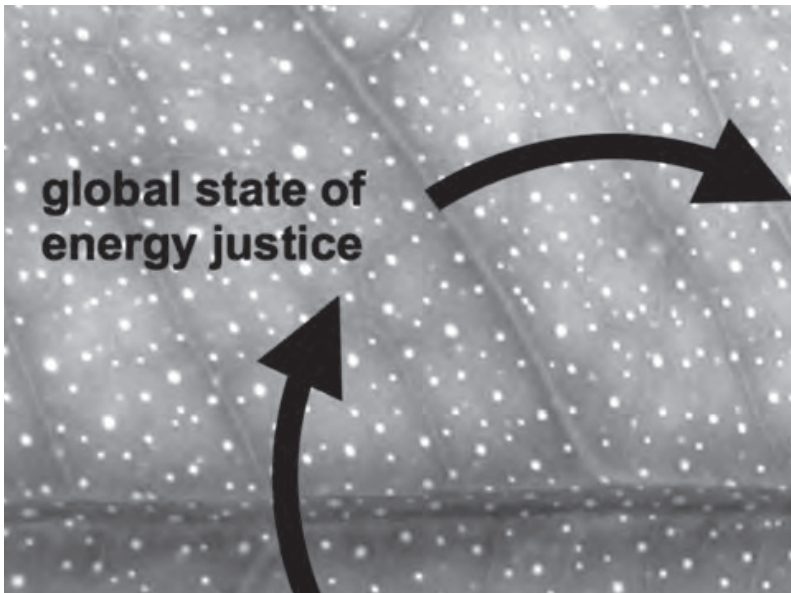

Preferred state.¹⁸

Local Strategies for a global solution

South Sudan by *Ayuen G. Ajok*

Due to the current difficulties in the area of energy development in South Sudan, Juba, the capital city, was chosen as the geographical area to develop a local strategy. This underdevelopment of the city means a strategy based on renewable energy can be designed and implemented without competing against existing infrastructure.¹⁹

Currently, residents in Juba are dependent on the use of diesel generators for electricity which is very expensive.²⁰ Developing an energy system that is cost efficient or better yet, economically beneficial to residents would help decrease the level of poverty in the city.²¹ There is great potential to develop solar and wind energy schemes in Juba which would eradicate the cost of fuel.²² Juba is located on the border of the White Nile, so there is also potential to install micro-hydroelectricity systems on smaller arms of the river.

The benefits from the implementation of renewable energy would include²³:

- Reduced dependency on generators to produce electricity will cut pollution and hazards to human health.
- Juba's infrastructure will improve drastically in the long run.
- Following the Stiftung's Solar Energy in Ethiopia model, explained below, will create training and employment opportunities.
- Economic benefits to residents through fuel cost reduction and business opportunities such as mobile phone charging or other services that rely on electricity.
- In the long-term, the potential to export of electricity to other parts of the country.

Off-grid solar system.²⁴



Neighbouring Ethiopia offers a template for the spread of renewable energy systems in Juba. The Solar Energy Foundation (Stiftung Solarenergie), a German charity, partnered with the Ethiopian town of Rema in 2008 to bring solar electricity to the community. Instead of merely installing solar systems, the foundation helped to set up a training centre for off-grid systems. The result is social development and economic prosperity with more than one million people who have benefited from the scheme so far. Replicating this system in Juba will generate electricity for local communities.²⁵

Every installation consists of the following components²⁶:

- A photovoltaic module which generates electricity from sunlight
- A rechargeable battery to store electricity so it is available both day and night
- A charge controller which prevents the battery from being overcharged or deep discharged.

The cost of a solar system is approximately \$260, including manufacturing and installation. A basic fee to pay the local technicians for regular maintenance work costs each household between \$0.09 and \$1.20.²⁷

Funding to replicate this system in Juba can come from:

- Diversion of oil profits towards renewable energy systems

Installation of off-grid solar energy by Solar Energy Foundation.²⁸



Micro-finance Partnership with NGOs and the World Bank

Pakistan by Rabia Sana

Pakistan’s energy supply currently comes primarily from indigenous natural gas which amounts to 45% of the energy mix. Oil imports contribute 35%, hydro power 12%, coal 6% and nuclear power 2% respectively.²⁹ Our strategy calls for this predominately fossil fuel reliance to give way to a diverse portfolio of renewable energy supplies that provide green jobs and sustainable supplies of relatively clean energy.

Steady growth in renewable energy sources including micro-hydro, solar and wind needs to become the foundation for a diverse energy mix to maximise Pakistan’s economic and social wellbeing.

There are 50,000 villages in Pakistan that are not connected to the national grid according to a report by the Solar Energy Research Centre (SERC). Due to distances to grid infrastructure, providing these households with a solar system would be more cost-efficient than connecting them to the distant grid. This would empower people both economically and socially.^{30, 31}

Direct
Normal Solar
Radiation.³²

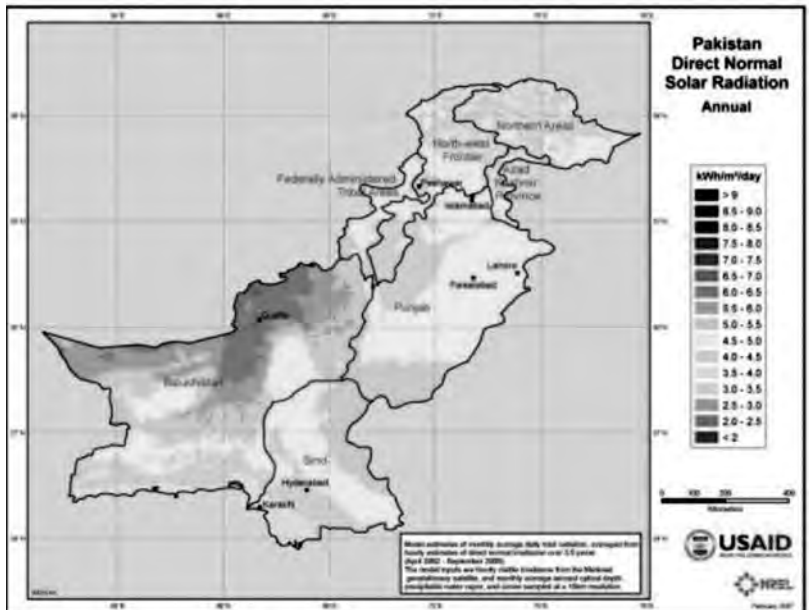

Being an agrarian economy, Pakistan generates vast amounts of agricultural waste which is currently burnt, left in the fields or used as fodder. There is an opportunity to turn this waste into a valuable resource in the form of bio-fuels. Research conducted by the University of Agriculture, Faisalabad, indicates that Pakistan has almost 3,000 MW power generation potential in just the sugar industry through biogas production from sugar cane waste. At the moment, the sugar cane industry is producing some 700 MW. In addition, it is estimated that Pakistan has almost 159 million animals that produce almost 652 million kilograms of manure daily from cattle and buffalo only, which can be used to generate 16.3 million-cubic-meters biogas per day and 21 million tonnes of bio fertiliser per year. It can easily compensate around 20 per cent of nitrogen and 66 per cent of phosphorus requirement in the crop fields as well. [footnote]

Similar to solar energy and biofuels potentials, Pakistan has an enormous potential for wind energy. According to data published by Miriam Katz of the Environmental Peace Review, Pakistan is fortunate to have something many other countries do not, which is high wind speeds near major cities. Near Islamabad, the wind speed varies from 6.2 to 7.4 meters per second (between 13.8 and 16.5 miles per hour). Near Karachi, the range is between 6.2 and 6.9 (between 13.8 and 15.4 miles per hour). However, purchasing wind turbines from foreign manufacturers is costly. An alternative strategy would be the development of an industrial sector in Pakistan which is able to manufacture wind turbines. This could reduce the capital investment required for large scale deployment of wind power plants and also create employment opportunities along the way.

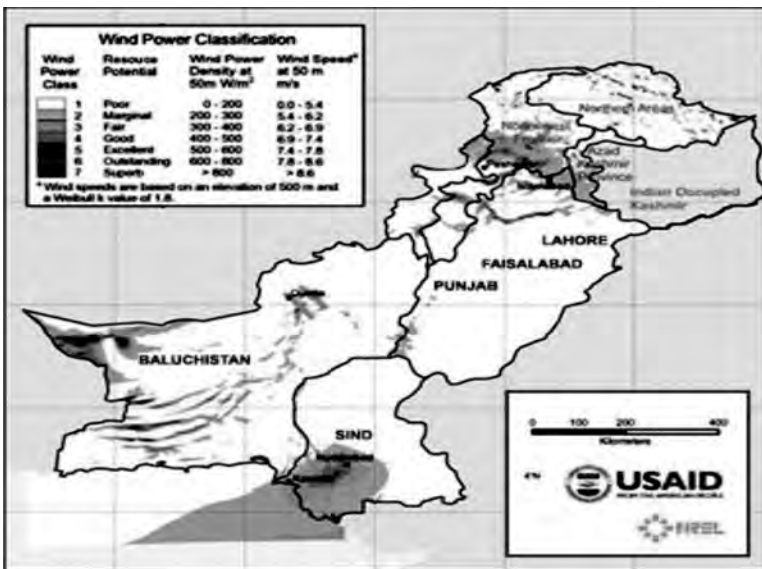

Wind Power Classification³³

Apart from drastically increasing the effort to spread renewable energy technologies that benefit individuals and communities, society needs to increase the efficiency of energy usage. A local Pakistani organisation conducted audits of 25 textile mills and suggested improvements in their energy management systems. This resulted in savings of 10 MW or Rs400 million (equivalent to \$4.25 million) for these 25 mills combined. The total investment of these mills to improve their energy management systems and conducting energy consumption audits was only \$532,000.

The Gambia by *Anne Schiffer*

The coastal town of Kartung in the south of the country has been chosen for the development of a local energy strategy. Two of the major concerns regarding energy in Kartung are an over-consumption of natural resources and a lack of infrastructure to provide a growing demand for electricity.

Locally there is an appreciation for the human impact on the natural habitat. Groups have formed with an interest to reverse these trends through such means as the restoration of mangrove forests.

Stand alone photovoltaic solar systems have been introduced into the community and are used both domestically and to power vital services such as Kartung's water supply.

Within the foreseeable future Kartung will be connected to national grid infrastructure. As the electricity provided through this will come from a diesel generator, it is likely to be costly and may not be available 24 hours a day. However, it does offer an opportunity to create a mini-grid based on renewable energy in Kartung that in turn is connected to the larger grid. The benefits of this include:

- promotion of renewable energy in Kartung that is based on solar energy
- an alternative to electricity storage in batteries
- an opportunity for Kartung to export electricity through a feed-in tariff scheme
- balancing out the intermittent supply of renewable energy particularly during the rainy season.

A similar scheme has already been pioneered approximately 30km north in the town of Batakunku and could be used as a template for Kartung. Batakunku is home to West Africa's first large wind turbine (150kW) which powers a mini grid that is connected to national grid infrastructure.



150kW wind turbine, in Batakunku, The Gambia.³⁴

To be able to build upon these trends and opportunities, and design a coherent energy management system it is necessary to first measure and estimate present and future demand for and availability of energy resources. At present, there is no accounting methodology used in Kartung to quantify these. Therefore the proposed strategy focuses on this first step and advises a partnership between local groups and an external expert to develop an appropriate methodology to account for energy resource demand and availability.

This will be accomplished in the first six months of the overall strategy. The goals include:

- generation of quantitative data to monitor energy supply, needs, and resource availability
- empowerment of local decision makers
- local employment for the development and maintenance of the energy management system
- development of a tool that can be used in other parts of the global south to help meet energy needs in sustainable ways.

The approximate cost for a six month project of this kind is \$8.600. (Table 1).

| | |
|--|--------|
| Wage for local expert and external energy consultant over six months | \$1560 |
| Transport of energy consultant | \$2000 |
| Equipment | \$2000 |
| Miscellaneous | \$1000 |
| Dissemination of methodology | \$2000 |
| Total | \$8560 |

Table 1: Cost of six month project to develop an energy management system for Kartung

The following points may be explored during the development of an accounting methodology:

- The high dependency on locally sourced wood fuel in Kartung and the fact that forest areas are in direct competition with other activities including rice cultivation, grazing livestock and the expansion of housing, suggests a methodology that quantifies areas of land available for energy resources. This also has the benefit that the methodology can be transferred to other essential issues such as local food production and energy systems become an integrated part of overall land management.
- In addition the methodology has to account for fuel and services imported into the community which could be measured in economic terms. Potential export of electricity and the current sales of wood fuels to urban areas may also be considered here.
- On the demand side, cost for imported energy fuels and services, the amount of wood fuels consumed per capita and the number of households without electricity supply should be considered.
- The emphasis is on developing a methodology from the bottom-up to ensure local ownership and usability.

Japan by *Yosuke Tanabe*

Under severe pressure from the public, the Japanese government introduced a national Feed-in Tariff on the 1st July 2012. Under this scheme individuals and co-operatives are able to generate electricity and sell this to the national grid. This is an opportunity for a radical change in mindset where economic gain from the electricity generation is no longer reserved for large corporations³⁵ but accessible to individuals³⁶.

Japanese people have real power to change the country's energy system:

1. The Japanese Feed-in Tariff is funded by a surcharge added on electricity bills.³⁷ In other words, it relies on the capital of individual people.
2. The average household pays \$102.35/month (\$1=JP¥80) for conventional electricity.³⁸ If 100,000 people who took part in the anti-nuclear rally³⁹ decided to invest the money they spend on energy bills in renewable energy it would amount to \$10 million investment each month.

What is urgently needed is comprehensive information that enables individuals and community groups to exploit the Feed-in Tariff to help

Japan achieve the transition to renewable energy sources. Our strategy proposes to develop a free *Guide to Renewable Energy in Japan*. It would be available online and as a document that the electric company would distribute to all its customers. The following is an outline of the *Guide*:

Guide to Renewable Energy in Japan⁴⁰

1. Towards Renewable Energy

The introductory chapter outlines a vision of Japan based on renewable energy with a strong emphasis on community schemes and the role of this guide in promoting that vision.

2. Current Energy State in Japan

This chapter describes the current state of energy in Japan. A deeper understanding of the problem provides an incentive for a quick transition to the renewable energy. This section will be updated regularly to reflect ongoing changes in the energy system.

3. Action as Individual

Chapter three offers practical tips for individual households such as energy saving and understanding domestic energy consumption. This chapter is simple and fun in order for the reader to enjoy challenges to improve the energy consumption in their home.

4. Getting Together

Armed with information from chapter 1-3, chapter four will guide the reader to start a group with people who share a similar interest in energy issues. It is intended to inspire the reader to think big and beyond the limitations of their home.

5. Community Generation in Renewable Way

This chapter offer guidance on how to sustain group action. The reader will learn how to make the most of the Feed-in Tariff with different renewable energy technologies.

6. Make It

Chapter six will help the reader test the feasibility of ideas and offer practical advice to move theoretical plans into reality.

7. Case Study

This chapter offers case studies from Japan and across the world with helpful links to find more information. This section will be updated frequently.

8. Resources

This section lists essential resources, including books, websites and relevant organisations.

The approximate cost for a six months project to develop the *Guide to Renewable Energy in Japan* portal and document is \$15,000 as shown in Table 2.

| | |
|--|-----------------------|
| Wage for web designer | USD 1000 |
| Wage for local staff to maintain web page (2 person) | USD 2000/month |
| Miscellaneous | USD 2000 |
| TOTAL | USD 3000 + 2000/month |

Table 2: Cost to establish *Guide to Renewable Energy in Japan*

Conclusion

The renewable energy advocate Hermann Scheer recognised that a transition to a global state of renewable energy needs a decentralised supply that matches decentralised consumption and shifts power to individuals and communities.⁴¹ In line with this, the key strategies developed by the team are as follows:

South Sudan

Setting up solar energy training centre to spread solar technology and shift dependency away from oil.

Pakistan

Creating a diverse energy mix based on renewables.

The Gambia

Developing an appropriate energy accountancy methodology to inform the design and management of sustainable electricity and wood fuel systems.

Japan

Creating an online information portal that will help individuals and co-operatives implement renewable energy systems and make use of the newly introduced Feed-in Tariff.

Sources

- 1 Scheer, H. (2010) *Der Energethische Imperative: 100 Prozent jetzt: Wie der vollständige Wechsel zu erneuerbaren Energien zu realisieren ist*. München, Verlag Antje Kunstmann.
- 2 *Peters Projection (without flags)*. (n.d.) [Online Image]. Available from: <http://upload.wikimedia.org/wikipedia/commons/thumb/f/f5/Peters_projection_blank.svg/1024px-Peters_projection_blank.svg.png> [Accessed 22 July 2012].
- 3 *Coal mine*. (n.d.) [Online Image]. Available from <http://www.news-business.net/wp-content/uploads/2010/05/Mining_Companies.jpg> [Accessed 22 July 2012].
- 4 *Nuclear power plant*. (n.d.) [Online Image]. Available from <http://www.jstevenwood.com/images/UK05_085.jpg> [Accessed 22 July 2012].
- 5 *Effects of global warming: drought* (n.d.) [Online Image]. Available from <http://www.instablogsimages.com/1/2011/08/26/drought_and_heat_wave_7lbyg.jpg> [Accessed 22 July 2012].
- 6 http://pdf.usaid.gov/pdf_docs/PDACP157.pdf
- 7 http://www.ifdc.org/Nations/South_Sudan
- 8 Ibid
- 9 Ibid
- 10 Ibid
- 11 qbal S., 2012 *Energy crisis, causes & remedies*, Pakistan Observer. <http://pakobserver.net/detailnews.asp?id=35838>
- 12 Khalid A., 2012, *5 steps to solving Pakistan's energy crisis*, The Express Tribune Blogs. <http://blogs.tribune.com.pk/story/10507/5-steps-to-solving-pakistans-energy-crisis/>
- 13 Schiffer, A. (2010) *Mass charging of mobile phones in Gambian village* [Photograph].
- 14 Agency of Natural Resources and Energy 2010, *Energy in Japan 2010*, Fig.10, page 9, *Ministry of Economy, Trade and Industry*. <http://www.enecho.meti.go.jp/topics/energy-in-japan/english2010.pdf>
- 15 Agency of Natural Resources and Energy 2010, *Energy in Japan 2010*, page 11, *Ministry of Economy, Trade and Industry*.
- 16 Renewable Energy World Editors, 2011, *Japan Poll: Switch to Renewables, But Take it Slow*, *Renewable Energy World.com*. <http://www.renewableenergyworld.com/rea/news/article/2011/08/japan-poll-switch-to-renewables-but-take-it-slow>
- 17 Willacy, M., 2011, *Tokyo anti-nuclear rally draws thousands*, *ABC News*. <http://www.abc.net.au/news/2011-09-20/tokyo-anti-nuclear-rally-draws->

- thousands/2907108
- 18 *Chlorophyll* (n.d.) [Online Image]. Available from <[[http://rpfmedia.ask.com/ts?u=/wikipedia/commons/thumb/a/a1/Citrus_leaf\(crop\).jpg/140px-Citrus_leaf\(crop\).jpg](http://rpfmedia.ask.com/ts?u=/wikipedia/commons/thumb/a/a1/Citrus_leaf(crop).jpg/140px-Citrus_leaf(crop).jpg)]> Accessed 22 July 2012.
- 19, 20, 21, 22: http://www.ifdc.org/Nations/South_Sudan
- 23 <http://www.stiftung-solarenergie.org/Pilot-Solar-village-Rema,602.html>
- 24 [Online Image] Available from <<http://www.greenpowerup.com/wp-content/uploads/2012/05/Indigo-South-Sudan2.jpg>>
- 25 <http://www.stiftung-solarenergie.org/Pilot-Solar-village-Rema,602.html>
- 26, 27: <http://www.planetedentrepreneurs.com/planete/?p=910&lang=en>
- 28 [Online Image] Available from <http://farm3.staticflickr.com/2786/4132138328_78e1d00b0b_z.jpg>

PAKISTAN

- 29: *Pakistan Energy Conference*, April 10-12, 2011, Sarena Hotel, Islamabad. <http://www.pakistanenergyconference.com/>
- 30 Kartz M., 2012, *The feasibility of renewable Energy in Pakistan*, Triple Bottom-Line Blog. <http://www.tbl.com.pk/the-feasibility-of-renewable-energy-in-pakistan/>
- 31 Munawar A., Solar Energy, *Energy and Renewable Energy Scenario of Pakistan* Page 5, Pakistan Council of Renewable Energy Technologies. [www.research.org.pk/Energy and renewable energy scenario in pakistan.pdf](http://www.research.org.pk/Energy%20and%20renewable%20energy%20scenario%20in%20pakistan.pdf)
- 32 [Online Image] Available from <<http://www.cleanbiz.asia/image/pakistans-solar-energy-potential>> 27 July 2012.
- 34 Schiffer, A. (2010) *Batakunku wind turbine* [Photograph].
- 35 Kaneshima, H. and Yamauchi, R., 2012, "Feed-in tariff energy system gets under way", *Daily Yomiuri Online*. <http://www.yomiuri.co.jp/dy/national/T120702004231.htm>
- 36 Asahi Shimbun Writer, 2012, "No more Nuke: Farm group in Fukushima starts production with Solar energy", *The Asahi Shimbun Digital*. <http://www.asahi.com/special/10005/TKY201207170113.html> (in Japanese)
- 37 Johnston, E., 2012, "New feed-in tariff system a rush to get renewable in play," *The Japan Times ONLINE*.
- 38 Statistical Research and Training Institute, 2012, "Report of family budget survey 2011", Table I-1-2, page 7, *Ministry of Internal Affairs and Communication*. www.stat.go.jp/data/kakei/sokuhou/nen/pdf/gk01.pdf (in Japanese)
- 39 Tabuchi, H., 2012, "Tokyo Rally is Biggest Yet to Oppose Nuclear Plan", *The New York Times*. <http://www.nytimes.com/2012/07/17/world/asia/thousands-gather-in-tokyo-to-protest-nuclear-restart.html>
- 40 Clark, D. and Chadwick, M., 2011, *THE ROUGH GUIDE to Community Energy, ROUGH GUIDES*. http://roughguide.to/communityenergy/RG_Community_Energy.pdf
- 41: Scheer, H. (2010) *Der Energetische Imperative: 100 Prozent jetzt: Wie der vollständige Wechsel zu erneuerbaren Energien zu realisieren ist*. München, Verlag Antje Kunstmann.

8. AIRVENGERS

by Kaycee Flore, Hillary Fronk and Heather McAdams

Strategic Summary: *Air pollution causes more deaths than AIDS and malaria combined. Green walls and roofs are an efficient and effective way of dealing with this problem that is affordable. Benefits include the removal of particulate matter from the air as well as other harmful toxins that can cause health issues such as repertory illness, asthma, cancer, and can even lead to death. The technology is available and the workforce is ready. What are lacking are the incentives to move forward. Through a set of tax and other incentives, cities can quickly implement enough green roofs and walls throughout their area to impact the quality of air and the health of their citizens.*

Introduction

According to the World Health Organization, approximately 3.3 million people died in 2013 from outdoor air pollution. This makes air pollution the source of more deaths than AIDS and malaria combined.¹

One of the most dangerous forms of air pollution is particulate matter. This pollutant can be broken down into two subclasses, PM10 and PM2.5. The subclasses of particulate matter differ by particle size and the way that they enter the body; PM10 enters the body through the lungs and PM2.5 enters the body through the blood stream.² Unfortunately, there appear to be no safe exposure levels for particulate matter (PM2.5 and PM10).

In addition to particulates, there are toxins in the air that very dangerous. These include formaldehyde (CH₂O), which is found in plastic products. It enters the indoor environment through natural sources such as forest fires and certain human activities, including burning tobacco, gasoline and wood. It is present, in its breathable gas form, in virtually all homes and buildings. Studies have suggested that people who are exposed to low levels of formaldehyde for long periods of time are more likely to experience asthma-related respiratory symptoms, such as coughing and wheezing. In higher amounts formaldehyde is known to cause cancer of the nasal cavity.³

Volatile organic compounds (VOC's) are found in all petroleum products. The main reason to be be worried about VOCs is because they are the primary precursor to the formation of ground level ozone

and particulate matter in the atmosphere which are the main ingredients of the air pollutant referred to as smog. The negative health effects of smog are well documented.⁴

Carbon monoxide (CO) is present in high concentrations in cigarette smoke and vehicle exhaust. Low level exposure causes dizziness and headaches while more acute exposure can lead to death because CO actually prevents the delivery of oxygen to the body's cells.⁵

Benzene (C₆H₆), Toluene (C₇H₈) and Xylene (C₈H₁₀) are found in the vapor of products such as gasoline, oils, paints, glues, inks, plastics, and rubber. They are skin and eye irritants and are known carcinogens, in connection to human leukemia.

According to the Environmental Protection Agency, “people living and working in buildings of manmade materials inhale over 300 contaminants every day.” Concerns about these contaminants arise from the hypothesis that, when combined, the toxicity of hundreds of different chemicals can add up to create major health hazards.⁶

An ancient Chinese proverb states “*If we do not change our direction, we are likely to end up where we are headed*”. The below graph illustrates the predicted global killers in 2010, 2030 and 2050 if we continue at are current levels of pollution without mitigation.⁷

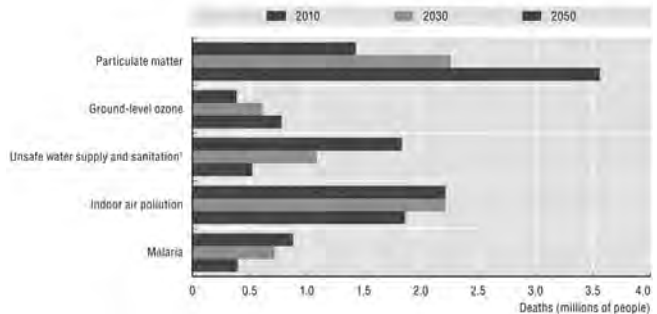

Strategy: Green Walls and Green Roofs

As a way of dealing with many forms of air pollution, including particulate matter, our strategy calls for the widespread use of green walls and roofs. These are building walls covered in plants that transform the barren wall in to a living wall. Green walls are self-sustaining vertical gardens attached to the exterior or interior of a building. Green roofs are self-sustaining rooftop gardens.

The benefits include the removal of particulate matter from the air as well as other harmful toxins that can cause health issues such as respiratory illness, asthma, cancer, and can even lead to death.



Other benefits of green walls and roofs include the filtering and removal of toxins. They also add energy rich oxygen. This reduces repertory illness related to air pollution. In addition, recent reports carried out at American and European Universities show that simply having a view of plants in a working environment provides

positive physiological responses. This translates into greater employee efficiency that results in increased earnings for a company. A study carried out at Washington State University had participants' blood pressure and emotions monitored while completing a simple, timed computer task in the presence or absence of plants. It concluded that when plants were added to this interior space, the participants were more productive (12% quicker reaction time) and less stressed (lower blood pressure).⁸

Utilizing green walls and green roofs reduces the "urban heat island effect." Instead of storm water running off of the building it is collected by the green wall, thereby providing thermal insulation and cooling the air. In addition to also collecting water and creating a cooling effect green roofs also keeps the buildings warm in the winter because the added soil provides an extra layer of insulation that keeps some of the heat from escaping through the top of the building.



Cost-Benefit Analysis

Tax and other policy options can encourage the widespread utilization of green roofs and walls as a way to mitigate the complex environmental problems facing urban centers in developing and developed countries.

Green roofs and walls are not used more because they have a high installation cost which deters initial investment.⁹ Looking at the benefits of green roofs and walls and not just the costs leads to a more balanced rationale for their immediate and widespread use. Specific benefits that should be noted are roof longevity, reduced storm water runoff, decreased energy consumption, biodiversity benefits, reduced urban heat-island effects, and air pollution mitigation.¹⁰

One study, conducted at the University of Michigan, showed *annual* health benefits of \$895 to \$3,392 for a 2,000 square meter vegetated roof for the removal of just nitric oxide from polluted air. This study also assessed large-scale roof greening within the Detroit and Chicago metropolitan areas. Greening ten percent of metropolitan roofs

would result in 15,300 to 18,500 Mg of NO_x reduction (from direct and indirect uptake) reducing annual public health costs between \$25.8 million to \$97.7 million in Detroit and between \$31 million to \$118 million in Chicago.¹¹



Funding Green Roofs and Walls

The public sector can provide incentives to small and large corporations, and private apartment houses and residences to incorporate green roofs and walls into their buildings. Tax breaks and rate reductions for public utilities would be the primary tools for this.

Case Study

In order to demonstrate the need and utility of green walls, we performed a case study comparing Philadelphia (United States) and Ludhiana (India). Both cities are affected by smog and possess similar population sizes (both hold about 1.5 million people), but Ludhiana is one of the most polluted cities in the world.

Green walls have recently come to Philadelphia through an advanced green wall program. The state of the city in terms of air pollution required this—it is one of the most polluted cities in the United States, with 35 “unhealthy” days in 2012 (according to the Air Quality Index), and hundreds of thousands of people plagued by lung diseases (there are 150,000 cases of asthma, 50,000 cases of chronic bronchitis, and 20,000 cases of emphysema).¹² Philadelphia is an attractive location for a green wall center. It has 49 skyscrapers, which have the flat surfaces and roofs ideal for green walls.¹³

In rough comparison, there were 620,000 air quality related deaths in 2009 in India. That same year, environmental degradation cost India \$80 billion, or 5.7% of its GDP.¹⁴ In Ludhiana specifically, 200 people die prematurely due to air pollution every year. Unlike Philadelphia, which has 35 unhealthy days per year, most of Ludhiana’s year qualifies as unhealthy—its particulate matter concentration averages two to four times the healthy limit.¹⁵ The smog in the city is attributed



to boilers, thermal power plants, and cars. Meanwhile, the condition is exacerbated by seasonal rain and excessive dust.¹⁶

Ludhiana is an ideal city to implement green walls for a number of reasons. It is just recently beginning to develop in terms of skyscraper number, so the green walls can be added as the skyscrapers are built, rather than as retrofits. It also consists mostly of buildings with flat roofs and walls, making it easier to install green roofs on existing buildings.

Green Roofs and Walls Website

One facet of our strategy for spreading the use of green roofs and walls is the development of a *Green Roof and Walls website*. Its purpose is to inform the public, policy makers and the business community about the problems and severity of particulate matter in the air—and the options afforded by green roofs and walls. The site will provide a list of air pollutions for each city (utilizing in the U.S. the *Toxic Waste Inventory* that the US EPA maintains) as well as which plants remove those pollutants. There will be a list of which companies output what air pollution. This will allow individuals to see which industries are the main polluters and encourage informed consumerism and enabling transparency in the marketplace.

The website will provide a list of cities implementing green walls and their progress. It will sponsor a competition to see which city has the most green roofs and walls. In addition there will be information-based games related to green walls and roofs that will help inform and engage youth. The website will feature a meter that counts how many people in the world suffer from respiratory illness related to air pollution, as well as the number of green walls and roofs. There will be a section on which plants are the most effective to keep around the house for indoor clean air, as well as facts, tips and ideas for people to create a clean air living environment.

The Future

The implementation of green walls and green roofs in urban environments will bring with it economic, environmental and social benefits, including:

- The reduction of smog and airborne pollutants
- The addition of jobs and long-term employment opportunities
- A decrease in expenditures on air pollution related illnesses
- A decrease in expenditures on waste water management.

Endnotes

- 1 <http://www.who.int/ceh/risks/cehair/en/index.html>
- 2 <http://www.who.int/mediacentre/factsheets/fs313/en/index.html>
- 3 <http://greenovergrey.com/green-wall-benefits/overview.php>
- 4 Ibid
- 5 Ibid
- 6 Ibid
- 7 <http://www.oecd.org/env/indicators-modelling-outlooks/49846090.pdf>
- 8 Ibid
- 9 http://www.erb.umich.edu/News-and-Events/colloquium_papers/Clarketal.pdfAdam
- 10 <http://0go.galegroup.com.bianca.penlib.du.edu/ps/i.do?action=interpret&id=GAL E%7CA334277799&v=2.1&u=udenver&it=r&p=ITOF&sw=w&authCount=1>
- 11 http://www.erb.umich.edu/News-and-Events/colloquium_papers/Clarketal.pdfAdam
- 12] <http://blogs.phillymag.com/bewellphilly/2012/04/25/tenth-polluted-city/>
- 13] <http://www.emporis.com/statistics/most-skyscraper-cities-worldwide>
- 14 <http://blogs.worldbank.org/endpovertyinsouthasia/indias-air-pollution-woes>
- 15 <http://www.tribuneindia.com/2010/20100331/punjab.htm#4>
- 16 <http://india.blogs.nytimes.com/2012/02/01/indias-air-the-worlds-unhealthiest-study-says/>



STRATEGIC AREA II:

**REGIONAL
ENERGY SYSTEMS**

**9. Rural Electrification via
Small Scale Wind Power**

10. Tidal Power for India

9. RURAL ELECTRIFICATION VIA SMALL SCALE WIND POWER

by Angela Burcham and Daniele Seldomridge

***Strategic Summary:** There are over 1.6 billion people in the world without access to electricity. Nearly 80% (1 billion) of these people live in rural areas where the electric grid does not reach. Decentralized electricity production devices could make an enormous contribution in these regions. Small-scale wind generators, as outlined in the following, could meet many areas' electricity needs.*



Problem State

Almost all of rural Africa does not have electricity to meet basic needs. Electricity is unavailable, and when it is available, it is unreliable and not affordable by the people who need it the most.

Preferred State

Less developed areas of the world will have access to clean, safe, affordable, and renewable sources of energy.

Strategy

Motorwind is a small-scale wind powered electric generator capable of powering lights, radios, mobile phones and re-chargers for numerous battery powered devices. It is lightweight, easy to use, adaptable, modular and mobile.

***Motorwind*
Turbines in
Hong Kong**

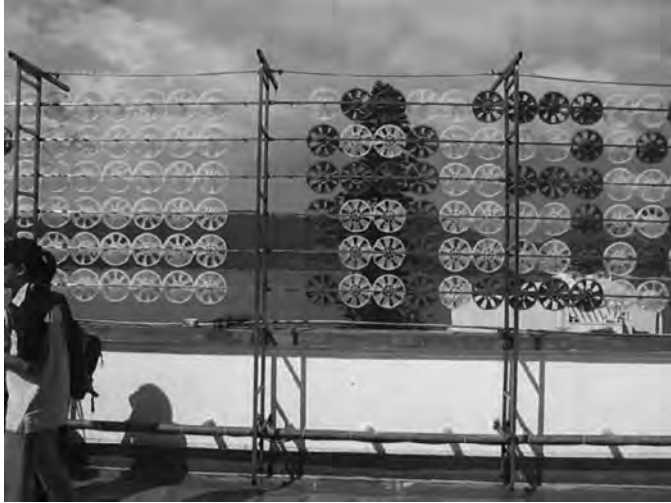

Very importantly, it works without being connected to the grid and its low cost makes it affordable for many areas of the world.

The *Motorwind* generator works in a minimum wind speed of 2m/s (4.47mile/hour) and can work in high wind speeds as well. It is a fairly low-tech device that can also store excess power in batteries. It is made from recycled plastics and is recyclable when its three- to five-year life span is over.

The cost for a set of eight *Motorwind* turbines is currently \$150. Cost will be reduced when the units are mass-produced.

This strategy calls for the mass distribution of *Motorwind* turbines to

rural areas in Africa by economic development non-governmental organizations. The costs of the devices will be borne by the recipients of the power. The initial capital to purchase the devices will come from mi-

Power collected with 20 turbines = 1 square meter

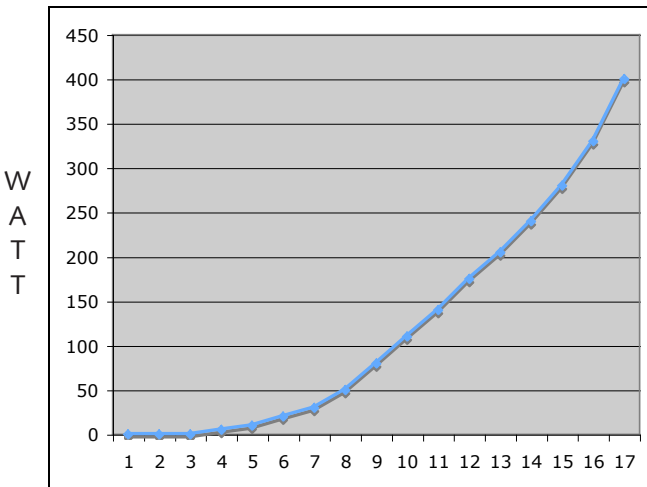

Wind speed in meters per second

From Basic Installations to supplementing the grid:¹

Electrical installation for basic lighting

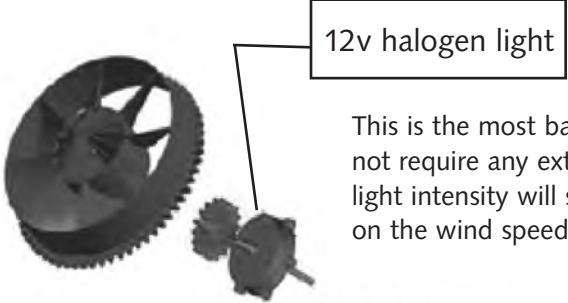

12v halogen light

This is the most basic installation. It does not require any extra components. The light intensity will simply vary depending on the wind speed.

Motorwave

Electrical installation for basic lighting

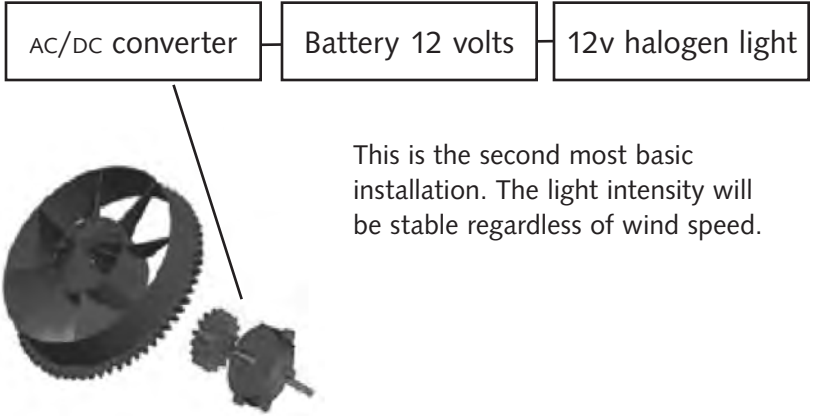

AC/DC converter — Battery 12 volts — 12v halogen light

This is the second most basic installation. The light intensity will be stable regardless of wind speed.

Motorwave

croloans. These will be paid back through the sale of electricity and the recharging of batteries to surrounding neighbors and other electricity using organizations and people.

Electrical installation with switch to the grid for unstable winds

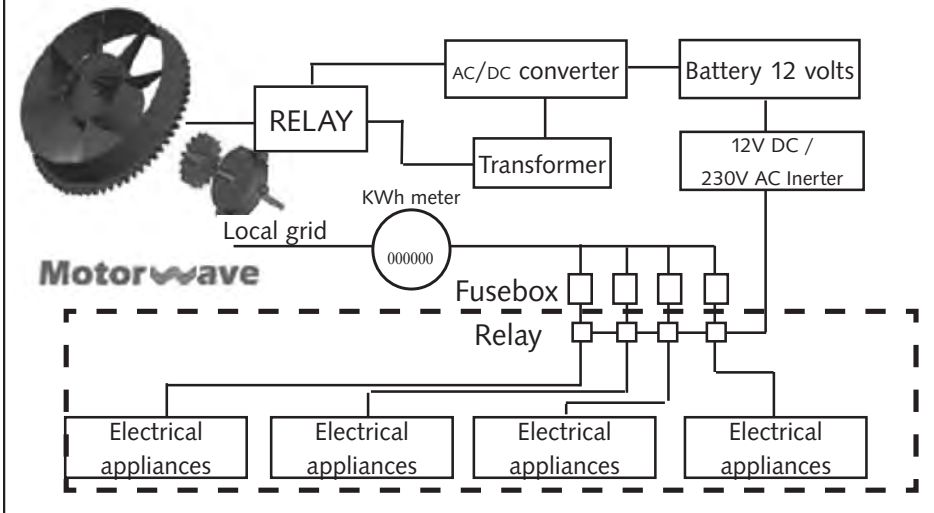

To supply a million families with basic electricity per year for ten years, so that approximately 50 million people are reached, would cost about \$100 million per year.²

Tanzania Case Study

In Tanzania, the average annual wind speed is 19 miles per hour. A single Microwind turbine will generate approximately 6.5 kWh/year in wind speeds of 5 meters per second (11 miles per hour). In wind speeds of 18mph, 25 kWh per year is generated. A 20 Microwind turbine installation would generate 500 kWh per year in Tanzania.³ A million Microwind installations in Tanzania would generate 500 million kWh of

Motorwind Power Output

| | | | | | | | | | |
|---------------------|-----|-----|---|----|------|------|----|----|-----|
| Wind speed m/sec. | 2 | 3 | 4 | 5 | 6 | 7 | 8 | 9 | 10 |
| Wind speed miles/hr | 4.5 | 5.5 | 9 | 11 | 13.5 | 15.5 | 18 | 20 | 22 |
| kWh w/ 8 turbines | 0.4 | 1.3 | 3 | 6 | 10 | 17 | 25 | 36 | 50 |
| kWh w/ 20 turbines | 1 | 3.3 | 8 | 15 | 27 | 42 | 64 | 91 | 125 |

electricity. This is 41% of Tanzania's total current consumption of electricity.⁴ As such, this amount would have a profound impact of the availability of electricity in the country.

Endnotes

- 1 Serengeti Genesis www.serengetigenesis.org, African Wind Energy Association t, Sustainable Africa www.sustainable.org.za
- 2 Each Motorwind turbine unit prices at \$100/unit
- 3 As measured in wind tunnel tests by Microwind
- 4 Total electricity consumption is 1.199 billion kWh in 2008 (*2008 CIA World Factbook*)

10. TIDAL POWER

HARNESSING AN INFINITE RESOURCE—INDIA AND BEYOND

By Emily G. Gleason

***Strategic Summary:** Tidal energy is a vast untapped energy source that could provide significant amounts of energy throughout the world. It can do this without increasing carbon inputs into the atmosphere. This strategy shows how developing nations, in particular India, can increase their electricity supply through tidal power.*



Present State

India is growing. Its population is at 1.1 billion people,¹ and an increasing amount of resources are needed to sustain its booming population and economic growth. India's energy demand grew by 6.8% in 2007, the third largest growth after China and the United States.²

One of the most significant energy resources needed is electricity. So far, India has approached this problem largely through coal power. India's coal consumption grew by 6.6% in 2007, compared to the average global rise of 4.5%.³ Thirty-eight percent of India's energy consumption is coal powered.⁴ In 2007, India consumed 208 million metric tons (in oil equivalent) of coal.⁵ India's overall energy demand is 404.4 million metric tons (in oil equivalent).⁶ Sectors that consume the most coal in India are the industrial sector at 29.4 thousand metric tons, the commercial sector at 2.9 thousand metric tons, and the public services and residential sector at 2.7 thousand metric tons (in oil equivalent).⁷

We have known for decades that coal combustion, although inexpensive in today's current monetary accounting systems, is very expensive in other areas. For example, it is unhealthy for the environment and detrimental to human health. Every year an average coal plant generates 3.7 million tons of carbon dioxide, 10 thousand tons of sulfur dioxide, 10 thousand tons of nitrogen oxide, 720 tons of carbon monoxide, as well as significant amounts of arsenic, mercury, lead, and airborne particles.⁸ These emissions have been proven to cause fatal illness such as respiratory disease and cancer. Sulfur dioxide is a source of acid rain that degrades the environment; carbon dioxide acts as a heat-trapping gas in the atmosphere and is the major contributor to global warming.

Preferred State

A preferred state to the current energy situation in India is one where India has a clean, abundant, affordable, and reliable supply of electricity that is produced in a sustainable manner.

Strategy

Tidal power electricity generation has minimal environmental impact, unlike coal and other fossil fuel power generation. It requires no fuel, and generates no pollution. Unlike wind turbines, there is little visual impact, as the turbines are submerged under water. Unlike hydroelectric dams, tidal turbines do not alter the flow of the current, block migration paths, nor require flooding and displacement of populations on surrounding

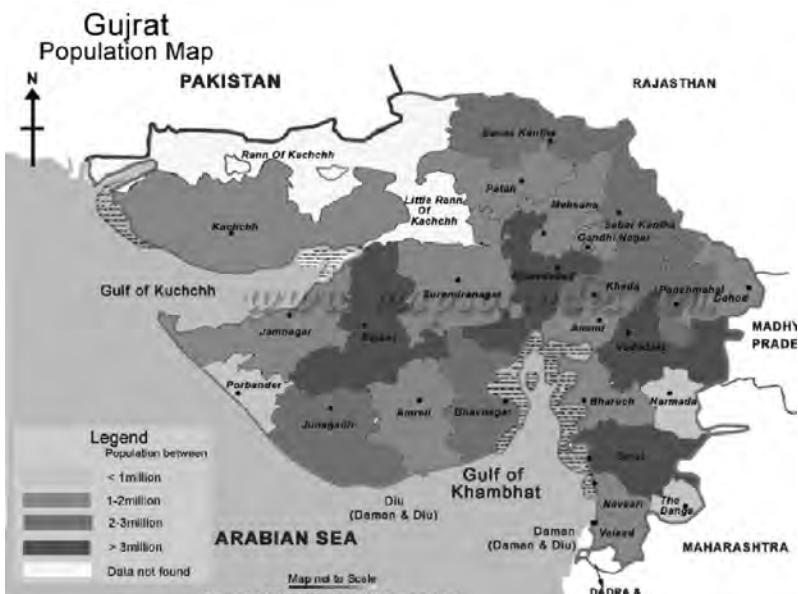

land. Some scientists even suggest that the turbines can become hubs of aquatic life as small organisms latch on the turbine attracting larger species.

Negative environmental effects are possible, such as sediment stir-up in the water, possible collisions with the moving blades by fish, and also a restriction on boat movement, depending on water depth. The major disadvantage of tidal power is that the technology for harnessing it has, up to now, been only suitable for large-scale tidal sites, and there are relatively few of these in the world.

Tidal power—the energy harnessed from the in and out-flows of the currents and tides—is a old energy source. But new technology for harnessing that energy source, made possible by advances in materials, turbines, and wind power, is now available. Some of the technologies are available now, others are in the testing stages.

One new technology is a turbine that is anchored to the sea or riverbed. Blades turn with the flow of the tidal (or river) current, which then turns a generator that feeds electrical current through a cable to a grid. These new tidal power turbines are comparable to wind turbines in design and mechanics.

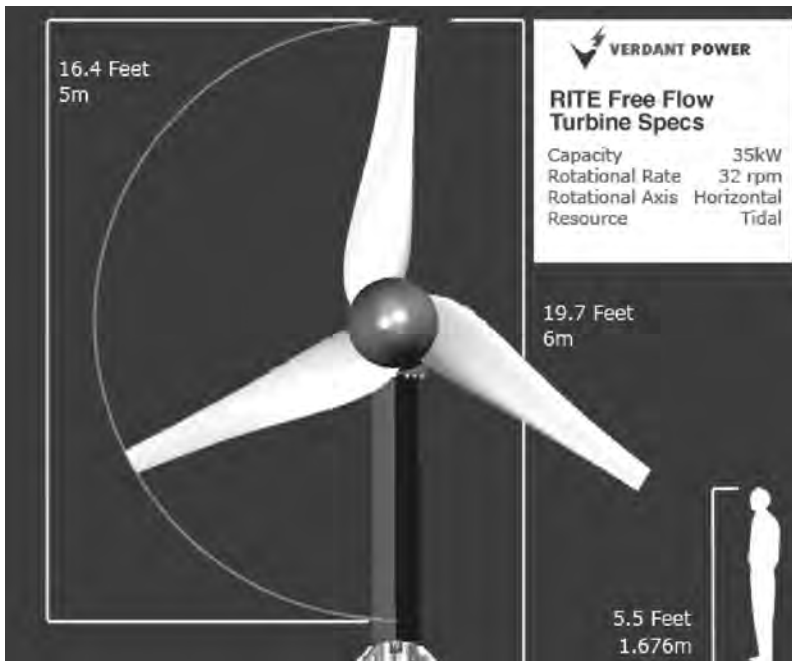

India Case Study

India could remedy its contributions to global climate change and reduce health risks to its citizens by reducing reliance on coal as an electricity source. This reduction should be part of a long-term plan to completely phase out coal as a source of electricity, and replace this energy with clean and sustainable energy. Although India has invested in wind turbines and a hydroelectric dam, a vast waterpower resource is left un-tapped in its two western gulfs: the Gulf of Kutch, and the Gulf of Khambhat. Both gulfs possess large tidal ranges and offer ideal environments for tidal power deployment.⁹

At its current stage of mechanical and economic development, tidal power is ideal to power small residential areas with a relatively low electricity demand—such as in the area around the Gulfs of Kutch and Khambhat.

There are several tidal power prototypes that have proven successful. A New York company, Verdant Power, has six three-blade tidal power turbines currently deployed in the Manhattan East River. The project was initiated in 2006, and completed in May 2007. The turbine units are six meters tall, with blade diameters of roughly five meters. Rated at 35 kilowatts, each turbine produces 665 kilowatt-hours running nineteen hours per day. The cost to consumers is 7 cents per kilowatt-hour. The cost per *prototype* turbine unit is \$4,800 per kilowatt. This high per-kilowatt amount will be lowered with mass-production of the turbines.¹⁰

The electricity generated by the turbines is being used to power a local grocery store, Gristede's Supermarket. The company projects that further expansion of turbines in the East River can produce up to 10 megawatts, enough to power 8,000 New York City homes.¹¹

Given enough space, the number of turbines can be increased to generate far greater amounts of electricity. The deployment of 1,000 turbines would produce 243 million kilowatt hours per year. Such an installation would cost an estimated \$70 to \$85 million, depending on the economics of turbine mass production.

Current prices for tidal turbine units are high relative to coal fueled power plants, but this cost discrepancy is expected to come down with mass production of the turbines, the removal of subsidies to the coal industry, and the added operating costs of coal plants when carbon emissions are figured into total costs.¹²

Government subsidies of tidal power and green energy could also help to cut costs significantly. Over all, tidal power right now costs less

in the long term, as it does not require fuel with its associated monetary and environmental expenses. Coal power, like other fossil fuel power generation, faces carbon taxation that will further hinder affordability. Coal, unlike tidal power, is a finite resource with serious environmental impacts and should therefore not be relied upon and invested in for the future.

With the goal of lowering India's coal dependence, and providing electricity for a growing population and economy, a tidal power plant could be installed in the Gulf of Kutch and the Gulf of Khambhat, using Verdant Power Inc.'s or similar technology.

Ideally, the Verdant Power tidal turbines would utilize and train local labor in installation and maintenance of the power system. One great advantage of the Verdant tidal power system over previous tidal power systems is that it can be expanded modularly. This will allow the tidal power system to grow as need expands.

In order for this tidal power project to have the most positive and sustainable impact on the local population, and India in general, the community needs to be informed and involved from the very beginning. Besides local employment opportunities, informational "town hall" type of meetings need to be held to answer questions and describe changes and opportunities the project will bring about.

Funding for the project could be obtained in a number of ways. Private investment, or a government or foundation grant to Verdant Power, or a similar company, would reduce their risk. Assistance from the Indian government could also provide incentive and reduce risk. Private investors with an interest in green energy could also be a funding source. The NGO community could be of help working with local citizens and insuring their interests and needs were fulfilled.

Beyond India

The governments of wealthy polluting nations, such as the United States, need to assume responsibility for their current and past environmental impacts. One constructive way of doing this that helps both a country such as the US, developing countries such as India, and the rest of the world, is for the US to fund, either outright or as a subsidy, the expansion of green energy technology in developing countries.

Through economic aid to energy-short developing countries and economic incentives within the US for an expanded use of green energy, a worldwide green energy revolution is feasible

Endnotes

- 1 Population Council. "Population." Asia:India. 2008. [3 August 2008] <http://www.popcouncil.org/asia/india.html>.
- 2 BP p.l.c. BP Statistical Review of World Energy 2008. Beacon Press, 2008. Pg. 2
- 3 Ibid, 3
- 4 International Energy Agency. "Share of Total Primary Energy Supply in 2005." 2007. [3 August 2008]
- 5 Ibid, 35
- 6 Ibid, 40
- 7 International Energy Agency. "2005 Energy Balances for India." 2007. [3 August 2008]
- 8 The Union of Concerned Scientists. "Environmental Impacts of Coal Power: Air Pollution." 2005. [3 August 2008]
- 9 India Energy: http://www.kpmg.co.il/Events/india/conference/thought%20leadership/IndiaEnergy_07.pdf
- 10 New York Tidal Project <http://www.reuk.co.uk/New-York-Tidal-Power-Project.htm>
- 11 Verdant Power Inc. "The RITE Project." 2008. [29 August 2008] <http://www.verdantpower.com/what-initiative>
- 12 Coal power plants produce electricity for about 5¢ to 8¢ per kWh. This cost will go up considerably when carbon has a cost associated with it and coal plants have to pay for dumping it into the atmosphere

Facing page: Large Aperture Trough, engineered by Gossamer and 3M, sets a new benchmark in solar collector technology for the concentrated solar power industry. (Photo: Gossamer Space Frames)

STRATEGIC AREA III: GLOBAL ENERGY SYSTEMS

- 11. Market Driven Energy Strategies**
- 12. Global Energy Corps**
- 13. Caron Subsidy Removal**
- 14. EmPower Book**
- 15. REST: Revamping the Energy System Today**

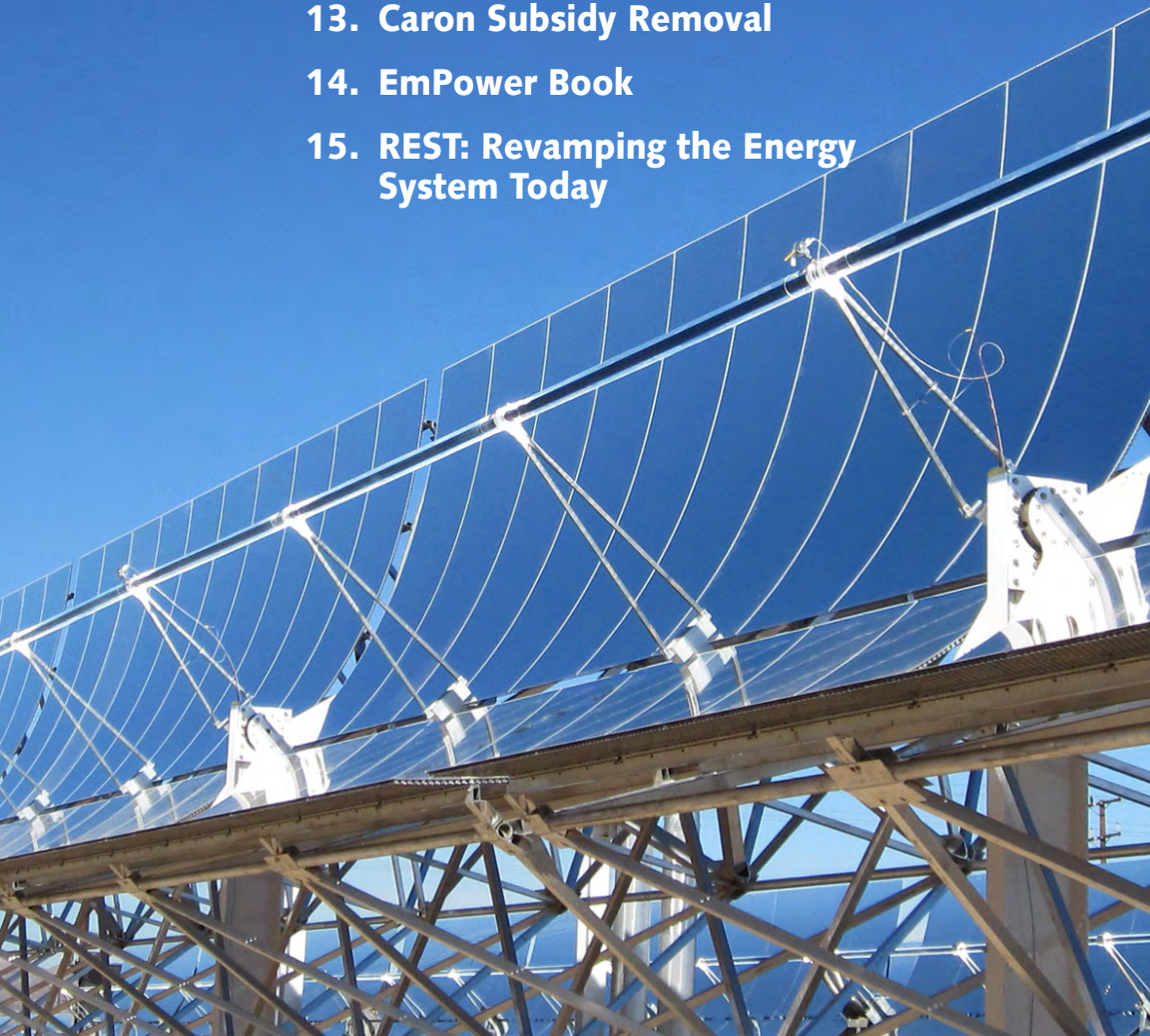

11. MARKET DRIVEN ENERGY STRATEGIES: CONVERTING CONVENTIONAL TO SUSTAINABLE

By Karen Guwuriro and Sam Little

***Strategic Summary:** The global energy market is one of the most important tools for providing manageable energy solutions to communities around the world. Through the removal of subsidies to the unsustainable and carbon-intensive sectors of the energy system, market forces will be able to assist in the transformation of the world's energy system.*

Present State

The current problems of the global energy system market include:

- Government subsidized energy supplies that mask the true costs of energy to the users of energy and its impacts on the environment
- Lack of incentives to invest in renewable energy
- Failure to internalize environmental and social costs in price of energy
- Unbalanced distribution and use of energy worldwide
- Overall low efficiency and high pollution of world energy market
- Newer, more sustainable energies with higher costs are in competition with subsidized conventional energies.

In summary, the current global energy system and market is centered around and held in place by artificial props in the form of monetary and other subsidies. The result is an artificially expensive, high profit for the few inefficient, polluting, non-sustainable industries that do not meet the energy needs of the world.

Preferred State

A global energy system and market that would be preferable to the current system is one that:

- Meets the needs of 100% of humanity
- Systematically reduces emissions and pollution and increases efficiency of energy generation, delivery and use
- Provides affordable energy for everyone from metropolitan areas to developing rural areas
- Is based on sustainable, renewable, clean and affordable energy sources.

Strategy

Globalizing Renewable Potential: Part 1

Markets tend to make better decisions the more informed they are. To make the transition from conventional carbon-intensive energy systems to sustainable, cleaner energy systems, the global energy market place will need some adjustments that, minimally, level the playing field so that renewable energy sources can compete.

Step 1: Subsidy Eradication

Step 1 in this process is to begin the phase-out of all subsidies to carbon-intensive energy systems. Currently these worldwide subsidies are \$250–\$300 billion for conventional energy sources. World coal receives \$63 billion.¹ Subsidies are provided to large energy companies for producing energy, and they are given by governments to promote the consumption of energy. Table 1 provides a glimpse of the positive impacts that could occur if these subsidies were removed.

We propose that this subsidy removal be done over a five-year period, with a 10% reduction immediately, a 25% reduction in year two, a 25% reduction in year three, a 25% reduction in year four and a 15% reduction in year five.

Step 2: Global Inventory and Assessment

Step 2 calls for a global inventory and assessment of best practices in the efficient use of energy in the industrial sector. Incentives for corporations to reduce their energy consumption by half or more will be set in place.

Table 1 Impact of the removal of energy consumption subsidies

| Country | Average rate of subsidy (% of market price) | Annual economic efficiency gain (% of GDP) | Reduction in energy consumption (%) | Reduction in CO ₂ emissions |
|--------------|---|--|-------------------------------------|--|
| China | 10.9 | 0.4 | 9.4 | 13.4 |
| Russia | 32.5 | 1.5 | 18.0 | 17.1 |
| India | 14.2 | 0.3 | 7.2 | 14.1 |
| Indonesia | 27.5 | 0.2 | 7.1 | 11.0 |
| Iran | 80.4 | 2.2 | 47.5 | 49.4 |
| South Africa | 6.4 | 0.1 | 6.3 | 8.1 |
| Venezuela | 57.6 | 1.2 | 24.9 | 26.1 |
| Kazakhstan | 18.2 | 1.0 | 19.2 | 22.8 |
| Total Sample | 21.1 | 0.7 | 12.8 | 16.0 |
| Total World | N/A | N/A | 3.5 | 4.6 |

Step 3: Global Efficiency Standards

Step 3 will set up high efficiency standards for all energy-consuming appliances, buildings and vehicles—and establish incentives and penalties for achieving these standards in ten years.

The *United Nations Framework Convention on Climate Change Technology Subprogramme* is a clearinghouse on technology transfer. We propose that an expansion of this system be used in the greening revolution needed to make the transition to a clean global energy system.

This UN program seeks to improve the flow of, access to, and quality of the information relating to the development and transfer of environmentally sound technologies.² By expanding and focusing it on green technologies, and specifically renewable energy harnessing and efficiency technologies, the market will be able to have access to reliable energy-related information.

Energy Assessments

Another part of the strategy is for development banks to offer voluntary energy saving assessments for all energy-intensive industrial sectors. For example, the European Bank for Reconstruction and Development (EBRD) instituted a system of “Polluter Pays” —a system that charges pollution emitters according to the cost of cleaning up their pollution, and that also provides compensation to non-emitters.

Fixed Feed-in Tariffs

Another tactic is the “Fixed Feed-in Tariffs” (FITs) that have been widely adopted in Europe. These have proved extremely successful in expanding wind energy in Germany, Spain, and Denmark. A feed-in tariff promotes renewable energy technologies that are not currently cost-competitive with subsidized fossil fuels. It does this by requiring electric companies to buy electricity that is produced from renewable energy producers at fixed prices over a fixed time period. This purchase price is fixed by estimating the cost of production or by paying a premium over the cost of subsidized fossil fuel electricity production. The additional costs of this electricity from renewable energy sources are passed on to the consumer in the form of higher end-user prices.³ Chart 2 documents the results of this strategy in Germany.

Germany gets more than 12% of its total electric energy from renewable power at a cost of about \$2.20 per month per home.

Chart 2 Development of the feed-in of renewables to the power grid in Germany

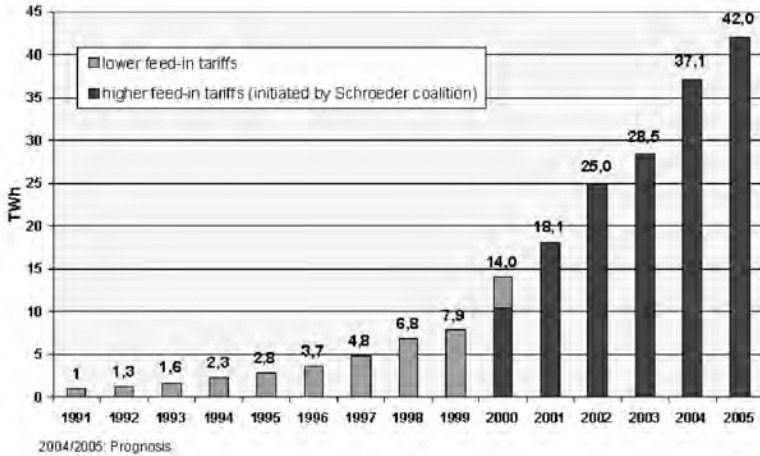

Globalizing Renewable Potential: Part 2

Renewable Targets

Establishing legally binding targets for renewable energy in large energy consuming countries will help undo the harm of decades-long subsidies to fossil fuel consumption. Using the EU's "Renewable Energy Roadmap" as a guideline, every country will establish similar binding targets for renewable energy.

The EU targets are:

- Renewable sources make up 12% of energy use by 2010
- Renewable sources to provide 21% of all electricity consumed by 2010
- Biofuels used in transport to reach 5.75% by 2010
- Electricity production from renewable sources will increase from the current 15% (in Europe) to approximately 34% of overall electricity consumption in 2020.

Endnotes

- 1 “Reforming Energy Subsidies: An Explanatory Summary of the Issues and Challenges in Removing or Modifying Subsidies on Energy That Undermine the Pursuit of Sustainable Development” UN
- 2 <http://ttclear.unfccc.int/ttclear/jsp/index.jsp>
- 3 “How Have Feed in Tariffs Affected Renewable Energy Production in Germany?”
<http://www.colby.edu/personal/t/thtieten/Nair.htm>

12. THE GLOBAL ENERGY CORPS

By Robert Fink

Strategic Summary: *A Global Energy Corps will be formed. It will be open to anyone from any country willing to make an 18- to 24-month commitment. Its mission will be to train members to be skilled green workers that can go into any part of the world and install renewable energy harnessing technology.*

Problem State

Affordable or clean energy supplies are not accessible by 100% of humanity. There is widespread inefficient consumption of energy resources. There are high emissions of CO₂ and other by-products of inefficient energy use. There is a lack of skilled workers able to install green technology and there is a lack of overall global communication and effective coordination among nation states concerning the global energy system.

Preferred State

One hundred percent of humanity has access to affordable, clean and abundant energy resources and these resources are used efficiently. As renewable energy is developed and fossil fuels are phased out, employment opportunities are made available to millions of people worldwide.

Strategy

A *Global Energy Corps* is set up with funds from governments, foundations, and investors. Continuing funding will come from an extremely small (0.001%) tax on all energy resource company's profits. In 2007 such a tax would yield over \$80 million.¹

The Corps recruits members who are then trained in reducing energy consumption through efficiency as well as in the installation of solar, wind, hydro, geothermal, and other renewable energy harnessing technology. These projects will be funded by the country where the projects are located and that benefits from the projects. If the country(s) does not have the financial capability to fund the project, the Global Energy Corps will provide a loan. This loan will be paid back from revenue provided by the new energy installation.

The Global Energy Corps is simultaneously organized around different regions of the world and different energy sources. Solar workers would be in touch with all other solar workers around the world—while “African solar workers” would be in touch with all other workers in Africa.

Endnotes

- 1 In 2007 Exxon/Mobil reported that it beat its own record for the highest profits ever recorded by any company, with net income rising 3 percent, to \$40.6 billion in 2007. If the Global Energy Corps taxed just the top ten petroleum refining corporations .001% of their profits, the Global Energy Corps would receive \$84,361,000 to fund its global renewable energy job training projects. <http://www.nytimes.com/2008/02/02/business/02oil.html>

13. CARBON SUBSIDY REMOVAL

By Ryan Martin, Bamini Balaji, Ross Brockwell, Kasia Chmielinski, Douglas Diaz, Victoria Farmer, Alexandra Heeney, Charles Sheldon

Fossil fuels receive many subsidies from governments around the world. These are in the form of price supports, tax breaks, low to no-cost licensing fees, publicly funded research and development, military expenditures in strategic locations to keep favorable governments in power and energy supplies secure, and unaccounted environmental and social costs. The amount of these subsidies is in the range of \$250 billion per year.²

A key strategy in reaching the preferred energy state is the phasing out of subsidies to fossil fuels so that they more accurately reflect their real costs to society and the global economy. This would include:

- Five year graduated (from current levels to zero) removal of all government subsidies to coal, oil, and natural gas
- The reallocation of R&D funds from fossil fuel industries to renewable energy industries
- Economic incentives that encourage investment in renewable energy and energy conservation.

The results of these moves would be a savings to global society of over \$200 billion in current expenditures on subsidies, plus, in just the US, a \$30 billion utility bills savings, \$6 billion in additional rural income, 90,000 new jobs (twice that from fossil fuels), plus less smog, acid rain, mercury contamination, and water use.³ On top of this the U.S would have a burgeoning industry of the future that can sell its products worldwide.

14. EMPOWER BOOK

By Ross Brockwell, Bamini Balaji, Kasia Chmielinski, Douglas Diaz, Victoria Farmer, Alexandra Heeney, Ryan Martin, Charles Sheldon

The *EmPower Book* is a local energy development manual. Its goal is to make energy-saving and -producing technology available in the developing world. It is a comprehensive guide/resource catalogue/manual that helps individuals and communities obtain access to energy and the conservation of energy—in its many forms and technologies. The “book” comes in a variety of forms—an actual paper book or online website and search engine with appropriate links to micro-loans and other services.

Funding would come from manufacturers whose products are listed in the EmPower Book and from ad revenue generated at the website by energy product companies whose products might be sold through the site. Micro-financing for obtaining the needed energy products will be part of the services offered by the EmPower Book.

Recipients of loans could sell the energy they produce to surrounding communities, thereby making enough money to repay the loan and to earn a steady income.

“The removal of fossil fuel subsidies has been advocated as the first order of priority in instituting economic policies to protect local and global environments.”

—World Bank

15. REST: REVAMPING THE ENERGY SYSTEM TODAY

“Without a shift to cleaner energy supplies it will be impossible to adequately tackle climate change.”

— U.N. Secretary General Ban Ki-moon¹

By Tariq Ausaf, Chris Cepil, Luca Dragani, and Dennis Yeh

***Strategic Summary:** With the world population continuing to grow, and expected to grow until at least 2050, and with modern, affordable, clean and reliable energy supplies still unavailable to a good percentage of that total population, there is need for more efficient and greener energy system. This strategic plan encompasses changes in the public sector and utilization of current technologies to generate an abundance of clean energy.*

Introduction

There are problems in the current energy system that is over-reliant upon fossil fuels. The system is economically, and environmentally unsustainable. It has high emissions, is inefficient in energy transmission and use, and has huge government subsidies. In addition, much of the rural and some of the urban areas suffer from shortages in electric energy that cause rolling blackouts year-round. In other parts of the world, energy is available but costly, inefficient, and polluting. A byproduct of this form energy usage is air pollution.

Problem State

Sixteen out of the twenty most polluted cities in the world are in China.² The most polluted city in terms of air quality is by far Linfen. Located in the Shanxi Province, Linfen is also the source of more than two-hundred unregulated coal mines. Once the coal has been mined, skipping the refining and cleaning phases that would reduce pollution, it passes directly to the coal-fired power plants where it produces electricity. As expected, this process creates pollution. When coupled with the fact that coal fired power plants produce half of China’s energy,

the problem becomes as serious concern to the entire planet. Pollutants deriving from this process include carbon monoxide, nitrogen oxides, particulate matters 2.5 and 10, sulfur dioxide, arsenic, lead, ammonia, and fly-ash.³ Adding to the list, more than 50% of well water was found to be so toxic that it could not be purified.

Statistics cannot describe how the citizens live every day, but this anecdote might begin to illustrate the underlying issue: Linfen was formerly known for its crystal spring water, arable agriculture, and diverse flowers. In its present state, a citizen of Linfen cannot even hang laundry outside for drying because the clothing turns black from fly-ash. Furthermore, three million people living in Linfen are affected by pollution caused by polluting energy sources.

Present State

Fossil fuel subsidies, according to the International Monetary Fund, are currently \$1.9 trillion per year.⁴ More than 2.5 billion people have inadequate access to energy to meet their needs.⁵ Of these, almost 830 million are without electricity, never having flicked a switch to turn on a light. In addition, every year, \$25 billion is lost in the transmission of fossil fuels.⁶

Biofuels, considered clean by most, consume about 6.5% of the world's grain and 8% of its vegetable oil.⁷ With so many still hungry, biofuels cannot be considered an ethical source of energy. In addition, burning biofuels produces greenhouse gases, including nitrous oxide, carbon monoxide, and carbon dioxide.

There are many causes for this situation. A lack of willingness in policy makers to challenge current energy subsidies and policies contributes to the problem. The development and start-up costs of new, cleaner energy solutions are too high due to the lack of subsidies for clean energies. The electric grid has not been updated in over fifty years. As a result, electricity cannot be transferred more than 1500 miles.

A number of experts expect the world population to exceed 9 billion by 2100.⁸ Currently, the power sector struggles to safely provide energy to 4 billion people. The power sector cannot expect to provide for more than double current consumption without innovation and cleaner energy solutions.

Preferred State

The preferred state that our group envisions is a world where: energy is *abundant* for all nations; it is *efficient*—the power grid loses less than 3% of its electricity over the course of 1500 miles; it is *affordable*—it is priced competitively and run by the private sector; it is *sustainable*—cities are self-sustaining, able to export supplies to other regions when necessary; it is *clean*—air pollution is kept to a minimum as fossil fuel usage is phased out; and, finally, it is *safe* and *reliable*.

Progress towards this preferred state will be measured in terms of the number of people with access to power, the number of blackouts and brownouts each year per area, the prices of clean versus unclean energy sources, relative pollution rates, and total and averaged reliable available power.

Strategy: Introduction

The sun is responsible for powering all life processes on Earth. Fossil fuels represent stored solar energy that has been collected by life forms more than two million years ago.⁹ It would be more efficient, and significantly safer to collect energy directly from the source. The entire human race uses about 400 quads Btu per year.¹⁰ Each year though, an excess of 8.2 million quads Btu reaches us on the surface of the Earth. This is more than 10,000 times the energy that all fossil fuel combustion in the world equal, in a year.

Strategy 1: Solar Windows

Solar Windows are a transparent solar panel that is four times more efficient at producing electricity than regular solar panels. These panels also act as insulators much like a heat sink, absorbing the heat from sunlight. Pythagoras Solar, based in Israel, manufactures them.¹¹

Solar Windows are ideal for cities with a high density of skyscrapers. Tall buildings are ideal. For example, the Willis Tower in Chicago (formerly the Sears Tower) has already started using solar glass. The south facing windows on the 56th floor of the Willis Tower were replaced with Solar Windows in November of 2011.¹² Each window, about 1 square meter, is capable of generating an excess of 120W of electricity. Each square meter costs about \$1500. Each year, the one



south facing side of the 56th floor of solar panels not only provides power for multiple floors and reduces heat indoors, but also saves the Willis Tower \$2 million on their energy bills. The glass pays for itself within five years.¹³

Assuming New York has 500 skyscrapers (it has more than this), there are at least 645 square kilometers of south facing surface area



on which solar glass can be placed. These 500 skyscrapers alone could produce 1,000 Kwh of electricity, enough to power 50,000 average American homes. In the top 100 skylines in the world, there are 76,117 skyscrapers.¹⁴ Globally, there are more than 200,000 skyscrapers. To produce *all* the electricity that the world currently uses, Solar Windows would only require about 100,000 skyscrapers.

There are obvious economic benefits to utilizing Solar Windows on skyscrapers.

- Saving an average of \$2 million per year per floor
- Solar Windows come with a lifetime guarantee
- Solar Windows pay themselves off completely within five years of installation, also guaranteed.

Strategy 2: Solar Farms

Dr. Gerhard Knies and Franz Trieb noticed that in just six hours of daylight, more energy reaches the Sahara than the entirety of mankind uses in one year.¹⁵ This research is the basis for DESERTEC, a non-profit foundation dedicated to creating cleaner and abundant energy supplies. The aim of this foundation is to generate renewable energies for the world through solar power in the Sahara Desert.

DESERTEC's solar farms are applicable all over the world. The vast deserts that have been previously considered barren can now be considered abundant sources electricity. The Sahara desert (9,400,000 km²), Arabian Desert (2,330,000 km²), Gobi Desert (1,300,000 km²), Kalahari Desert (900,000 km²), Patagonia Desert (670,000 km²), Great Victoria Desert (647,000 km²), Syrian Desert (520,000 km²), Mojave Desert (124,000 km²).¹⁶ occupy most inhabited time zones. Solar panels can be placed in these various deserts based on population and energy demand in nearby populated regions. About one percent of the Sahara desert (94,000 km²) would exceed all current human energy usage.

The Mojave and Patagonia deserts have slightly higher altitudes than most deserts, and because of this, have higher average wind speeds. This wind sweeps up the sand, which will in turn corrode and weather solar panels. Under proper conditions and optimal climate, solar panels will only last about twenty five years.¹⁷ Under harsh desert conditions with high winds, solar panels will probably last half as long. To compensate for this, the solar panels in zones that are deemed, "high risk," can be treated with a nanoparticle coating that would keep them from weathering and increase efficiency.¹⁸

Solar power can only be collected twelve hours a day on average in each time zone. In addition, some areas will have "bad weather," meaning clouds blocking sunlight, not permitting the collection of solar power. This presents a problem involving a need for excessive energy production during sunlight hours to power time zones during nighttime. There are two feasible options to provide for this: energy storage and an updated "smart grid."

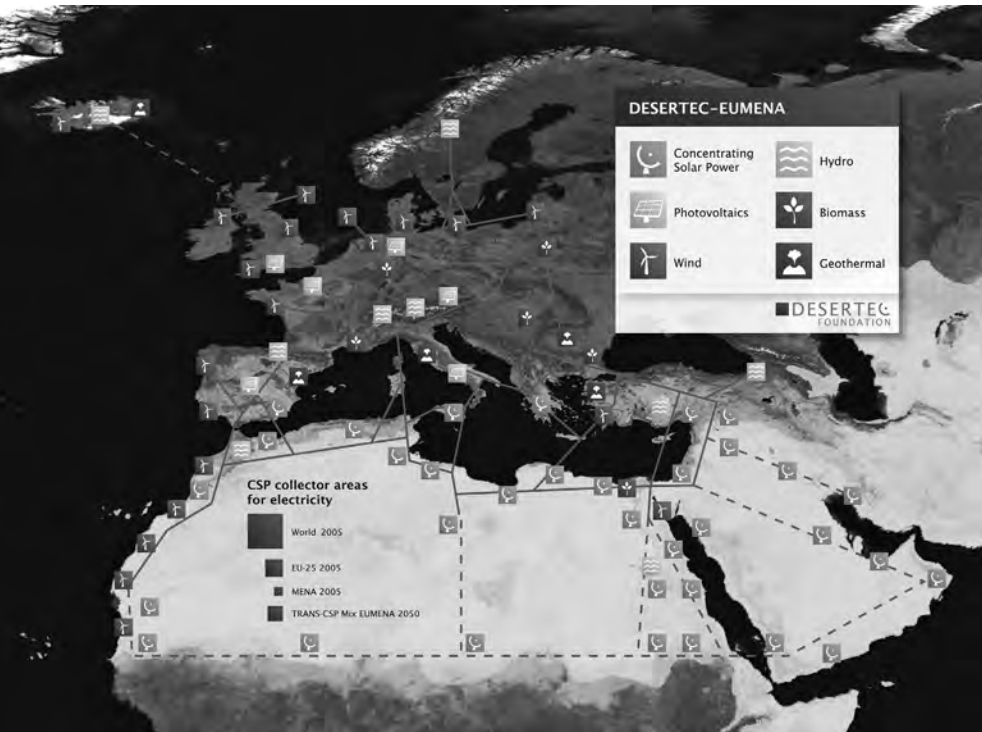

Strategy 3: Energy Storage

Conventional energy storage methods, i.e. current batteries, will not be able to economically store excessive amount of energy produced by Solar Windows and solar farms when implemented worldwide. Many other unconventional methods of energy storage are far too expensive and require nonrenewable resources. However, there are two methods, less expensive and more efficient, that will work when storing massive amounts of electricity for reuse: pumped-storage hydroelectricity and thermocline energy storage.

Pumped-storage hydroelectricity is a method widely tested and used. It involves pumping water back into the reservoir, using surplus energy and storing it (as water in the reservoir) for later use. Pumped-storage hydroelectricity works with between 80% and 87% efficiency, meaning that at least 80% of initial energy invested will be available for consumption.¹⁹ This is highly efficient compared to other methods of energy storage. (For example, electromechanical methods of energy storage are less than 75% efficient²⁰, super capacitors are around 60%

efficient, and the majority of other methods are between 70% and 75% efficient.²¹⁾

The cost of using pumped-storage hydroelectricity would be less than \$100 per kWh, far less than sodium ion flow batteries, which cost more than \$400 per kWh.²² Additionally, the more hydroelectric storage is used, the less it costs per kWh. This method is also completely green, reliant only upon water.

Because pumped-storage hydroelectricity takes advantage of pumping water back up into a reservoir, it can be implemented anywhere there is an already existing dam. More than 80 countries host dams already pumped-storage prepared or capable of being turned into a pumped-storage dam. These dams have the combined ability to store more than half a year's worth of the world's energy consumption. Additionally, the cost of implementation is low because these already existing dams can easily be turned into pumped storage systems for storage huge amounts of energy. No people need to be relocated in order to flood a river at this point; more than enough dams are in working order for implementation.

Thermocline energy storage is another efficient and less expensive energy storage system. It costs \$.078 per kWh.²³ To give you an idea of how inexpensive this is, the US Department of Energy goal is \$15 per kWh. The average efficiency of the thermocline energy storage system is 93.7%. There are currently two methods of thermocline tank storage: single tank systems and double tank systems.²⁴

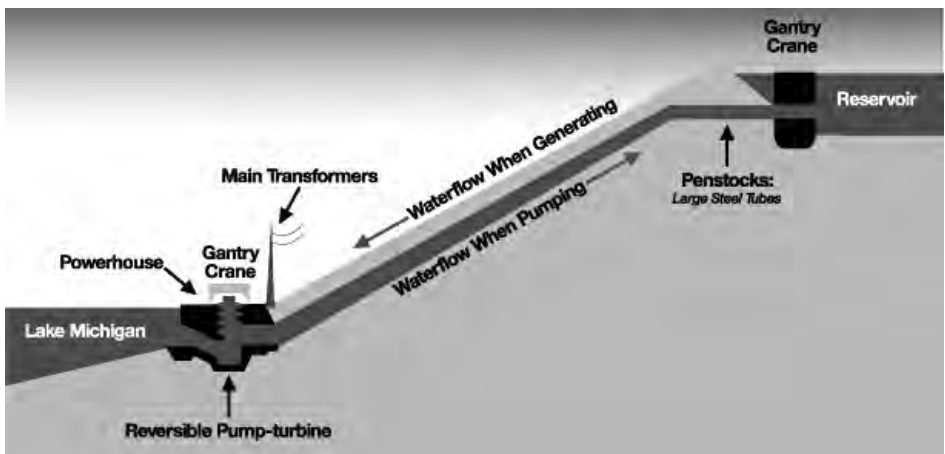

In a double tank thermocline system, the hot and cold liquids, which are typically molten salts, are stored in separate tanks. Energy is stored by transferring excessive heat from the hot to the cold tank. When energy is extracted, the process is reversed and heat is turned back into electricity and delivered to the power block. Single tank thermocline systems prove to be more efficient and cost-effective than double-tank systems by integrating both tanks into a single unit where electricity is not lost in the transfer of heat between tanks. In this system, the cold remains at the bottom while the hot remains at the top. The one tank system is thus most effective and should be used in tandem with our system.

The thermocline energy storage one tank system was developed with implementation in mind. One-tank systems were meant to store energy specifically from solar farms. At each solar facility there can be a storage area where thermocline tanks have been installed and connected to a power block for maximum efficiency.

Strategy 4: The Smart Grid

The current U.S. electrical grid was designed between 1900 and 1920, when it was built and connected individual power utilities to each other after already connecting to households.²⁵ It has been over fifty years since this grid, has been system wide updated. Current weaknesses include occasional blackouts and brownouts, the inability to transmit electricity further than 7000 km, loss of 4.2% of electricity ever 100 mi, and a host of other issues.²⁶ Although the system was designed to

transmit electricity from areas with excess to areas with minimal electrical production, it no longer can meet the needs of our electrical system.

More than 500 companies run the current energy grid in the United States. Government regulation is needed to insure that there is complete coverage, adequate supplies and investment and no price fixing.



Multiple levels of integration—interoperability
 Distributed Generation Renewable Generation Storage Demand Response

Our group's aim is more comprehensive than just an update of the current system of electrical transmission. The system we are proposing would be automated with efficient transfer of energy between nations and cities to keep all regions amply powered. It would be a system that connects the world to solar desert collection centers, Solar Windows outfitted cities, pumped-storage hydroelectric and other energy storage facilities.

A feasible goal for this is high-voltage direct current (HVDC) energy transfer is where less than 3% of energy is lost every 1500km, which has been researched extensively and proven cost effective in Germany. Our system would make the grid more reliable, flexible and economical. Our Smart Grid system would allow and incentivize current energy companies to transition into the new green system, which is addressed in our next section.

Strategy 5: The Transition

The Smart Grid can be implemented anywhere, existing power grid or not. The first focus for the smart grid is to implement it in developing countries, mainly where power grids are not already in place. Developing countries with no power grids in place are generally the ones without power to begin with—thereby addressing our goal to supply those without any power first. Excess power can be supplied to those in need first, before being stored.

There are at least three ways the Smart Grid and other facets of our overall strategy could be implemented. The private sector could pay for the solution, the government could, the private individual or family could pay for their part of the grid—or there could be a combination of the three. Whoever pays for the grid, it should be a public utility and regulated as such. There could be energy usage limits per household, mandatory installation of smart grid capable meters and other requirements.

Strategy 6: Costs and Subsidies

“Who is going to pay for these solutions?”

One recommendation set forth by the UN in Agenda 21 was a tax on fossil fuels in order to develop and implement “environmentally sound technologies.”²⁷ By taxing an average of \$50 per ton of fossil fuels in the U.S., more than \$500 billion could be generated each year.²⁸

Subsidies are responsible for great inefficiencies in the global energy system. Fossil fuel subsidies are extraordinary: \$1.9 *trillion* according to the IMF. Subsidies supporting green technologies are comparatively

nonexistent. Part of our strategy is to increase subsidies for green technologies. Over time, the fossil fuels subsidies need to be reduced to nothing, while subsidies for green technologies can gradually increase, and then, once established, dramatically decrease.

After implementation of green technologies, much less is required for upkeep than in fossil fuels, and subsidies will not be needed to keep the technologies cost effective. What is being paid for by subsidies after implementation of green technology is development and eventual revision of green technologies. Saving money in the long term is the outcome of subsidizing green technology.

Some of these subsidies could be focused on grants and programs incentivizing current companies harvesting fossil fuels to move toward completely green technology. In this way, the fossil fuel industry would not want to hinder the program, but capitalize on it.

Projected Timeline (2013–2050)

The strategies described here will take at least twenty years to implement fully. Our implementation timeline runs from the present day to 2030 to from the present day to 2050. It is our contention that the Preferred State could be reached by 2030 if an all-out effort was undertaken.

The UN's Sustainable Development Goals are focused primarily on developing countries. The energy system strategies described here should, based on the notion that those in greatest need should have priority, be implemented in the developing world before the wealthy world.

According to the UN, 68% of the population of developing countries lack access to reliable supplies of electricity.²⁹ We think our strategy is better implemented in places without reliable energy. It will have the biggest impacts in these locations. Developing, energy-short countries could use additional energy for better irrigation, power for equipment in schools and health centers, lighting, heating and cooling, and communication technologies.

The idea is not to replace the current market for energy. It is to transform and expand it. Overlap is also likely and will occur between technologies being implemented.

Phase 1: Example Argentina (2015–Dec. 2020)

To illustrate how our energy strategy will work, we will use Argentina as a demonstration.

Argentina is an ideal country to implement the testing phase of REST. Thirty percent of the population of Argentina is without power. There are many thousands of square miles of unused space in Argentina coupled with skyscrapers capable of hosting solar glass. The climate is mixed enough to test solar farms, with much of the Patagonia Desert's flat lands located in the western part of the country. The population, at 41 million, about 13% the population of the U.S., is large, but not overwhelming. Implementation in a country without an existing power grid might be easier, but Argentina's large power grid will serve as a test ground for implementation under tight economic conditions. 75% of the electricity sector of Argentina is owned by the private sector, so it could serve as a test of government and private sector cooperation and ownership of electrical utilities. In addition, hydroelectric dams are already in place where energy can be stored.

How it could work:

Working with the Argentina government and private energy sector, convene an *Energy Strategic Planning Consortium*. This would start with an Energy Sector Strategic Plan Workshop. This event would introduce REST to Argentinian government and private industry owners that are looking to expand economically and meet the energy needs of their country.

After this, there will be the need to formulate and implement policy changes over a two-year period (2015-2017). Developing incentives and subsidies that urge market forces to move in the direction of the Argentina Energy Preferred State that is developed at the Energy Sector Strategic Plan Workshop is essential. One way to fund the program would be a 1% tax on fossil fuels. This would be used to finance the energy transition described here.

- 1. Solar Windows (2015-2020).** The first technology to be implemented is Solar Windows. With 50% or more of the skyscrapers in Buenos Aires and other large cities in Argentina fully using Solar Windows, cities will become increasingly electricity self-reliant, if not self-sufficient (and possibly electricity exporters). The 1% Fossil Fuel Tax will be used to as a revolving loan fund to get the Solar Windows facet of our strategy off the ground and rapidly implemented.

2. **Smart Grid (2015-2018).** The smart grid would be implemented between solar glass and energy storage, as it is necessary for effective transportation of electricity between solar farms, energy storage, and rural areas. The way this would happen is the current grid governing agency, Fondo Fiduciario para el Transporte Eléctrico Federal, would have increased funding (from the 1% Fossil Fuel Tax), that would pay for the implementation of the new Smart Grid.
3. **Energy Storage (2017-2019).** Argentina has a lot of hydroelectric power. They have 19 hydroelectric dams and facilities capable of being converted into energy storage systems. The Yacyreta dam alone is capable of storing 3,400 MW of electric energy. Thermocline energy storage would also work well in Argentina.
4. **Solar farms (2017-2019).** More than half the eastern side of the Patagonia Desert would be a perfect place to test not only solar farms, but also the nanotechnology films resistance to wind and particulate matter that would ordinarily stick to the panels or damage them.

Consequences

Hydroelectric dams block the natural flow of water, as well as necessitating the relocating of people, wildlife and ecosystems in some areas. Dams, although rarely, can overflow and cause damage to the environment. They require attention and maintenance. Solar Windows and solar panels require energy to produce silicon. These solutions still use natural resources, and require an initial energy investment and monetary investment. These alternatives aren't blemish-free, but they are less expensive and environmentally destructive.

Simultaneous with rollout in Argentina, the energy strategy would be tested and improved in at least two additional countries—for example, the Philippines and South Africa. Implementation would be similar to Argentina, with the process tweaked to accommodate the unique opportunities and challenges in these countries.

The Philippines would be ideal for testing solar farms and glass in a tropical climate. Because of the scattered island geography, test the implementation of the smart grid and electrical storage systems. South Africa is slightly larger economically than Argentina. It will be a good start on the African continent.

Conclusion

Revamping the Energy System Today is economically feasible and would ensure a greener future for following generations. Global goals for energy should include universal access to modern, clean, abundant, secure, safe, and affordable energy supplies for all. The REST system is capable of meeting these goals.

Endnotes

- 1 United Nations. "ENERGY, DEVELOPMENT AND SECURITY: Energy issues in the current macroeconomic context." United Nations Industrial Development Organization. www.unido.org/fileadmin/user_media/Publications/documents/energy_development_and_security.pdf (accessed July 10, 2013).
- 2 World Bank Group. "Environment—Cost of Pollution in China: Economic Estimates of Physical Damages." The World Bank. <http://web.worldbank.org/WBSITE/EXTERNAL/COUNTRIES/EASTASIAPACIFICEXT/EXTEAPREGT/OPENENVIRONMENT/0,,contentMDK:21252897~pagePK:34004173~piPK:34003707~theSitePK:502886,00.html> (accessed July 10, 2013).
- 3 The Blacksmith Institute. "Linfen, China." Worst Polluted. www.worstpolluted.org/projects_reports/display/22 (accessed July 11, 2013).
- 4 Lipton, David. "Energy Subsidy Reform: The Way Forward" Presentation by David Lipton, First Deputy Managing Director, International Monetary Fund." International Monetary Fund. <http://www.imf.org/external/np/speeches/2013/032713.htm> (accessed July 11, 2013).
- 5 El-Badri, Abdallah Salem. "Striving for Stability in Global Energy Markets." Organization of the Petroleum Exporting Countries.
- 6 National Energy Technology Laboratory for the U.S. Department of Energy. "MODERN GRID BENEFITS." The NETL Modern Grid Initiative. www.netl.doe.gov/smartgrid/referenceshelf/whitepapers/Modern%20Grid%20Benefits_Final_v1_0.pdf (accessed July 11, 2013).
- 7 Walsh, Bryan. "Food Prices: Crisis Deepens as Biofuels Consume More Crops." TIME Science & Space. <http://www.time.com/time/health/article/0,8599,2048885,00.html> (accessed July 11, 2013).
- 8 Discovery Communications. "Population to Bulge, But Will Hit Ceiling." Discovery News. <http://news.discovery.com/human/population-boom-110729.htm> (accessed July 11, 2013).
- 9 University of California, San Diego. "The Electromagnetic Spectrum." Intro to Astronomy: The Live-Giving Sun. earthguide.ucsd.edu/virtualmuseum/ita/07_1.shtml (accessed July 12, 2013).
- 10 EcoWorld Media. "How Much Solar Energy Hits Earth?" EcoWorld Nature & Technology in Harmony. <http://www.ecoworld.com/energy-fuels/how-much-solar-energy-hits-earth.html> (accessed July 13, 2013).
- 11 Pythagoras Solar. "Pythagoras Solar Announces Photovoltaic Glass Unit (PVGU), First Green Building Material to Combine Energy Efficiency, High Density Solar Power Generation and Transparency." Pythagoras Solar. <http://www.pythagoras->

- solar.com/news/pythagoras-solar-announces-photovoltaic-glass-unit-pvgu-first-green-building-material-to-combine-energy-efficiency-high-density-solar-power-generation-and-transparency/ (accessed July 13, 2013).
- 12 Halverson, Nic. “Chicago’s Willis Tower to Harness Sunlight.” Discovery News. <http://news.discovery.com/tech/alternative-power-sources/chicagos-willis-tower-to-harness-sunlight-110328.htm> (accessed July 14, 2013).
 - 13 Pythagoras Solar. “Corporate Backgrounder.” Pythagoras Solar. www.pythagoras-solar.com/wp-content/uploads/2012/11/Pythagoras_Backgrounder_final2-1.pdf (accessed July 14, 2013).
 - 14 EMPORIS GMBH. “Skyline Ranking.” EMPORIS—Building data and construction projects worldwide. <http://www.emporis.com/statistics/skyline-ranking> (accessed July 29, 2013).
 - 15 Knies, Gerhard, and Franz Trieb. “Sun cheaper than Oil.” Franz Alt SONNENSEITE.com. www.franzalt.com/index.php?pageID=60&article:oid=a5823&template=article_detail.html (accessed July 15, 2013).
 - 16 Geology.com. “Largest Desert in the World—Desert Map.” Geology.com Geoscience News and Information. <http://geology.com/records/largest-desert.shtml> (accessed July 15, 2013).
 - 17 CivicSolar. “How Long Do Solar Panels Last?.” CivicSolar. <http://www.civicsolar.com/resource/how-long-do-solar-panels-last> (accessed July 16, 2013).
 - 18 Tolley, Laura. “UH PHYSICS RESEARCHER DEVELOPS NANOPARTICLE COATING FOR SOLAR PANELS.” University of Houston. <http://www.uh.edu/news-events/stories/2012/august/0813SolarPanelCoating.php> (accessed July 19, 2013).
 - 19 Jacob, Thierry. “Pumped storage in Switzerland—an outlook beyond 2000.” Stucky a Gruner company. www.stucky.ch/en/content/pdf/Pumped_storage_in_Switzerland_Dr_Jacob.pdf (accessed July 20, 2013).
 - 20 Mempin, Genaro. “Modular Electromechanical Batteries for Cost-Effective Bulk Storage of Electrical Energy.” Industrial Partnerships Office. https://ipo.llnl.gov/?q=technologies-modular_electromechanical_batteries (accessed July 21, 2013).
 - 21 The Economist Newspaper Limited. “Energy storage: Packing some power.” The Economist. <http://www.economist.com/node/21548495> (accessed July 21, 2013).
 - 22 Mandel, Jenny. “DOE Promotes Pumped Hydro as Option for Renewable Power Storage.” The New York Times. <http://www.nytimes.com/gwire/2010/10/15/15greenwire-doe-promotes-pumped-hydro-as-option-for-renewa-51805.html?pagewanted=all> (accessed July 21, 2013).
 - 23 Barile, Christopher. “Solar Thermal Energy Storage Systems.” Stanford University Physics Department. <http://large.stanford.edu/courses/2010/ph240/barile2/> (accessed July 29, 2013).
 - 24 Flueckiger, S. M., Z. Yang, and S. V. Garimella. “Design of Molten-Salt Thermocline Tanks for Solar Thermal Energy Storage.” Perdue E-Pubs. docs.lib.purdue.edu/cgi/viewcontent.cgi?article=1191&context=coolingpubs (accessed July 20, 2013).
 - 25 Borberly, A. and Kreider, J. F. (2001). *Distributed Generation: The Power Paradigm for the New Millennium*. CRC Press, Boca Raton, FL. 400 pgs. (accessed July 20 2013).
 - 26 Paris, L., G. Zini, M. Valtorta, and G. Manzoni. “Present Limits of Very Long

- Distance Transmission Systems.” Global Energy Network Institute. <http://www.geni.org/globalenergy/library/technical-articles/transmission/cigre/present-limits-of-very-long-distance-transmission-systems/> (accessed July 20, 2013).
- 27 United Nations. “ENERGY, DEVELOPMENT AND SECURITY: Energy issues in the current macroeconomic context.” United Nations Industrial Development Organization. www.unido.org/fileadmin/user_media/Publications/documents/energy_development_and_security.pdf (accessed July 10, 2013).
- 28 Spross, Jeff. “Bombshell IMF Study: United States Is World’s Number One Fossil Fuel Subsidizer.” ClimateProgress. <http://thinkprogress.org/climate/2013/03/29/1791811/bombshell-imf-study-united-sates-is-worlds-number-one-fossil-fuel-subsidizer/> (accessed July 21, 2013).
- 29 Watkins, Kevin. United Nations Development Programme. “Human Development Report 2007/2008 Fighting Climate Change: Human Solidarity in a Divided World.” Human Development Reports. hdr.undp.org/en/media/HDR_20072008_EN_Complete.pdf (accessed July 21, 2013).

16. CLIMATE CHANGE: TURBINES, FILTERS, TREES, AND INCENTIVES

By An Nguyen (Vietnam), Fawwaz Ali Khan (Pakistan), Gurinder Singh (India)

Strategic Summary: *Climate change is measurable changes in weather patterns over the years. Current changes to Earth's climate are primarily caused by the addition of excessive amounts of greenhouse gases into the atmosphere. These gases are mainly caused by the use of carbon-intensive, inefficient, wasteful and long-term expensive production of energy, food, industrial processes, transportation, combustion of fuels, improper waste management and other factors. The impacts of climate change are global and severe. Human health is compromised, food production undermined and the global economy damaged to the tune of over \$2 trillion per year. Impacts are most severe in the poorer regions of the world and upon people who have had little to nothing to do with changing the climate.*

The processes of climate change can be slowed and even reversed if environmental health and sustainability are prioritized, and industrial, energy, and materials use practices are changed.

The following strategy deals with the causes of climate change and is divided into two phases. Phase One focuses on cleaner energy production using underwater turbines and the use of new filter membranes on smoke outlets in industries that reduce climate change chemicals released into the atmosphere. Phase Two focuses on a) improving existing conditions of the environment by installing giant air purifiers and filters in heavily polluted areas of urban environments throughout the world; b) global school and curriculum based tree-planting programs that involve the students of the world; and c), serious penalties for climate change pollution and significant tax-break incentives for industries working in the field of green energy production.

Problem State

The severity of climate change and its impacts can be measured by:

- The *temperature* of the Earth and how it has changed over the years. The Earth naturally goes through cycles of warming and cooling but the difference has never been so large this quick.¹
- *Melting of glaciers* and ice sheets causing a *rise in global sea levels* which impacts hundreds of millions of people living near the sea shores.²
- *Seasonal and severe weather disruptions* around the world. Irregular monsoons, increased size and wind speeds of hurricanes, droughts and floods are some of the impacts of global rising temperatures.
- *Rising levels of air pollutants* and smog that it is affecting the health of millions of people around the world.³
- *Deforestation* is causing the loss of wildlife and also increases the carbon content in the atmosphere.

One measure of the cause of climate change is the amount of CO₂ and methane in the atmosphere. The following charts makes clear the historical severity of where our world is and is heading:

Global atmospheric concentration (ppb) over the years

CO₂ during ice ages and warm periods for the past 800,000 years

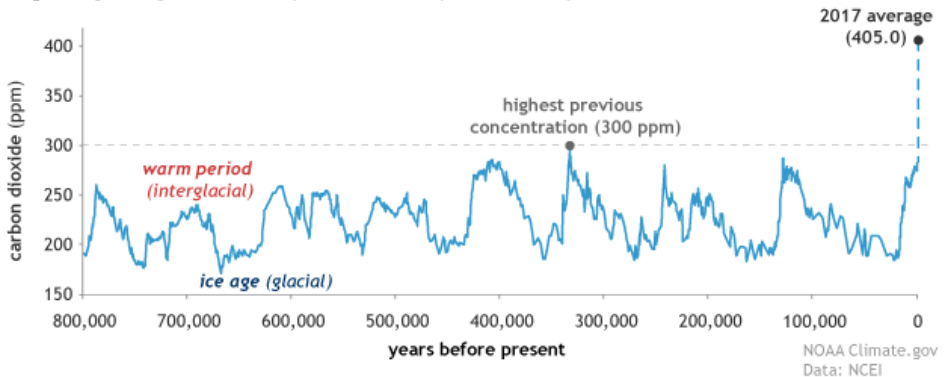

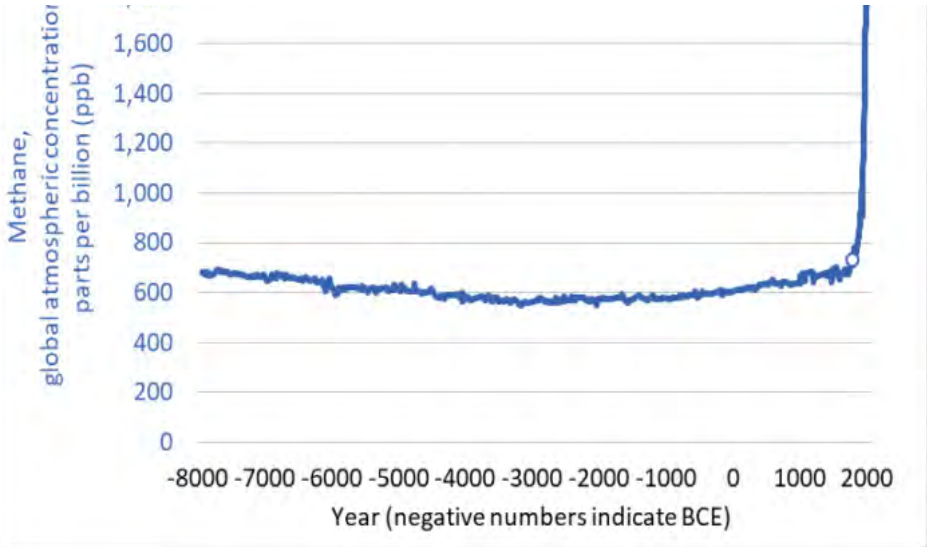

SATELLITE DATA: 1993-PRESENT

Data source: Satellite sea level observations
Credit: NASA Goddard Space Flight Center

RATE OF CHANGE

↑ **3.3**
millimeters per year

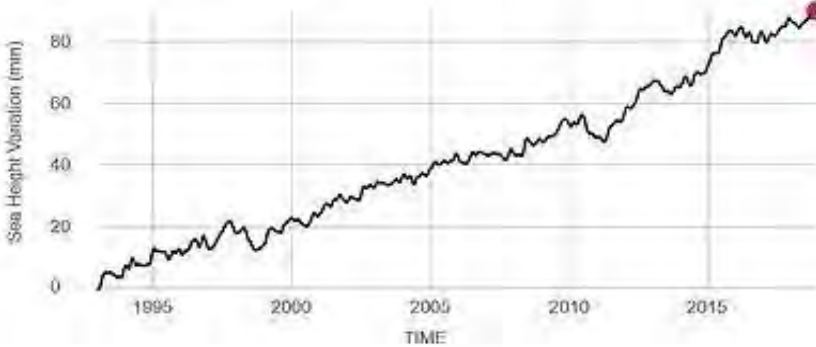

Variation in sea levels

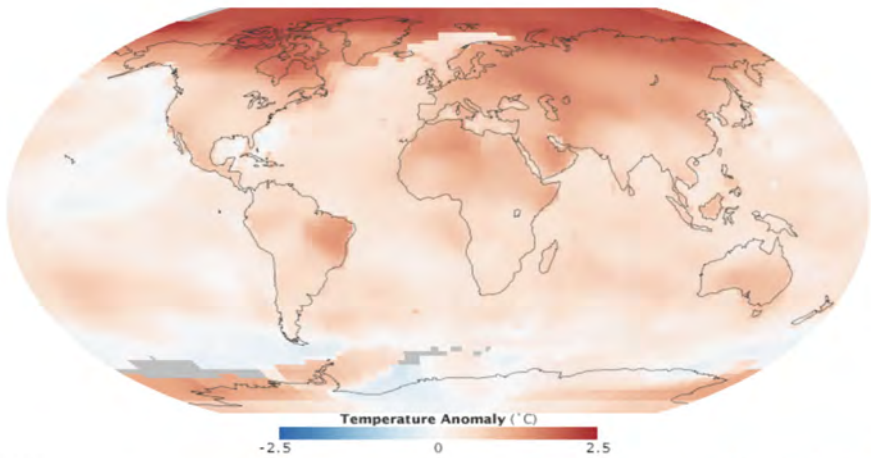

The above graphic shows the annual increase of temperature around the globe in 9 years (2005-2014). It can be seen that the change is maximum near the north pole and areas that surround it. Some parts of Asia, Africa and North America are seen to be the most affected due to high population and increasing demands.

Present State

The increasing amount of greenhouse gases present in the atmosphere is the main source of change in climate. These greenhouse gases include carbon dioxide, methane, nitrous oxide and others. CO₂ accounts for about 76 percent of total greenhouse gas emissions. Methane, primarily from agriculture, contributes 16 percent of greenhouse gas emissions, and nitrous oxide, mostly from industry and agriculture, contributes 6 percent to global emissions. All figures here are expressed in CO₂-equivalents.

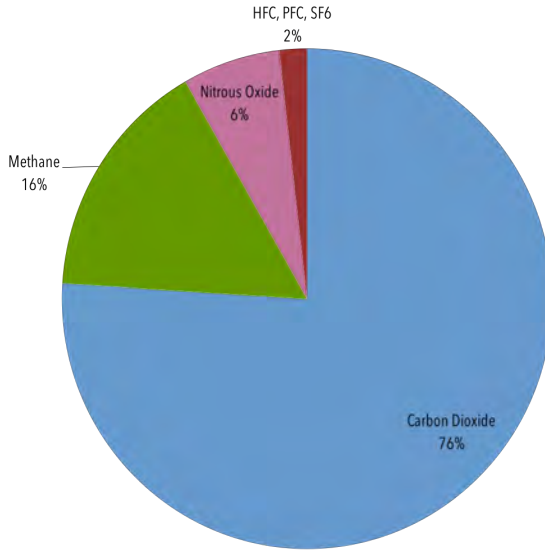

Inventory of U.S. Greenhouse Gas Emissions 1990-2015 (EPA, 2017)

Climate Analysis Indicators Tool (World Resources Institute, 2017)

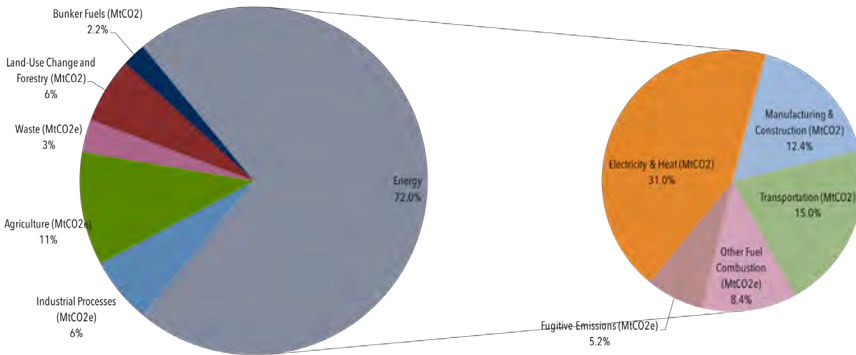

Globally, the primary sources of greenhouse gas emissions are the production of electricity and heat (31%), agriculture (11%), transportation (15%), forestry (6%) and manufacturing (12%). Energy production and consumption of all types accounts for 72% of all emissions.

Preferred State

A Preferred State for environmental and climate health and sustainability in the world is where there is a:

- Reduction to naturally sustainable levels of human-generated atmospheric emissions from combustion of energy, agriculture, industries and other sources.
- Stabilization of global temperature below the level that increases global warming.
- Switch to greener methods of energy production such as solar, wind, geothermal, tidal and others.
- 90% reduction of all carbon-intensive fuels.
- Restoration of forests to pre-industrial levels.
- Increase in youth and general public knowledge of, prioritization of, and involvement with the state of the world's climate and the factors that impact it.

Strategic Plan for Reducing the Impact of Climate Change and Achieving the Preferred State

Our strategy aims to first prevent further disruption of the existing global atmospheric environment by switching to greener methods of energy production as this sector comprises of 31% of total greenhouse gas emissions into the atmosphere.⁴

Phase One: Use of Underwater Turbines

Underwater (and tidal) turbines are a proven technology. Technological feasibility and proof of concept has occurred, in some cases, decades ago. They are essentially windmills installed onto an ocean floor or river bed. Underwater currents produced by tides (or rivers or ocean currents) spin blades arranged like an airplane propeller. These turbines are attached to a gear box, which is connected to an electrical generator. This produces electricity that is carried by cable to shore where it is plugged into an electrical grid and distributed. Turbines in water are more efficient than those in air as wind-flow is not be as strong and uniform. In addition, water is about 800 times denser than air⁵, therefore, water flow can produce more energy compared to a same sized turbine blade in air.

Use of Carbon Capture Membranes

An emerging, and successfully tested at industrial scale, technology that has great potential in combating climate change are carbon capture filters.⁶ These are an atmospheric filtration system that utilizes a semi-permeable membrane that allows beneficial atmospheric gasses to pass through while trapping carbon and other pollutants. These can be used to great affect for atmospheric purification purposes as well as eliminating pollutants released from factory emissions. The Bill and Melinda Gates Foundation has partially funded a plant of such filters with fans to circulate air through them and extract carbon and other pollutants that can then be harvested and disposed of or reused.

The carbon capture membranes provide a few advantages in their way of removing carbon. The cost is lower due to the use of a membrane on a semi-permeable substrate instead of a solvent or a sorbent to help catch carbon molecules. They are more efficient than other methods, being able to remove Hg vapor and H₂S in addition to standard carbon. Such technology can also be deployed easily into remote areas, such as the Gates Foundation-funded plant demonstrated.⁷ Multiple membranes can be included into a single module or unit which allows easier transportation and installation.

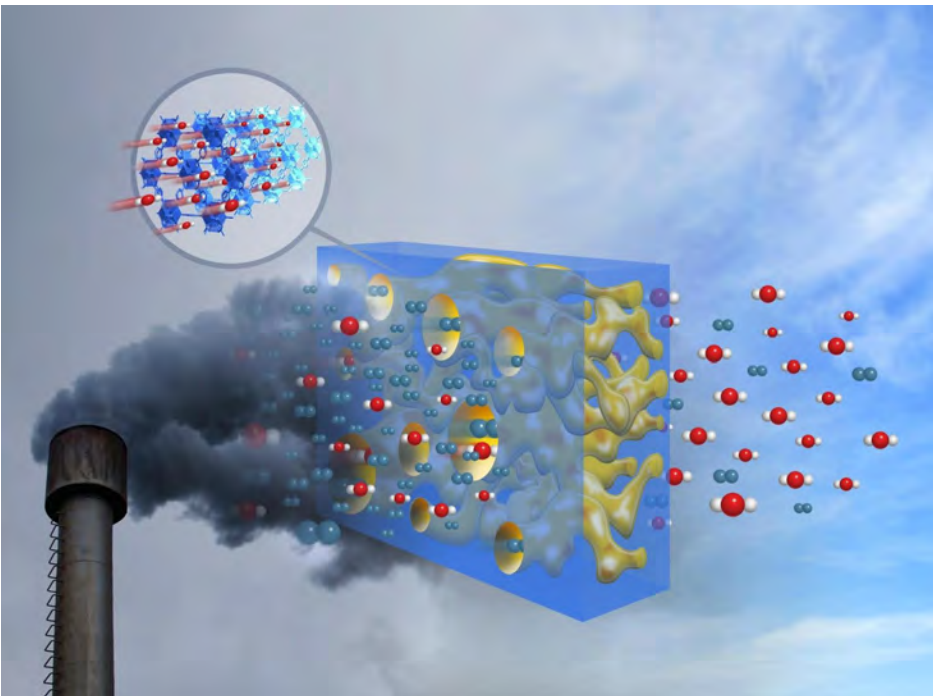

Graphical representation of carbon capture membrane that depicts how only the clean particles are released into the air whereas all the carbon and other harmful chemicals are captured within the membranes.

Phase Two: Large-Scale Air Filtering Towers and Machines

The second part of the strategy focuses on cutting existing atmospheric pollutants. This can be accomplished through the installation of giant air filtering machines and purifiers on a city-wide scale, such as the example installation below.



The above image shows an air purifying tower installed in a city of China. This purifying tower has the capacity to clean the air up to 10kms of radius around it.

Air Purifying towers are designed to consume minimum energy while maximizing output. The towers have greenhouse chambers at their base that absorb the sun's heat to increase the temperature of air captured inside. The hot and less dense air starts to rise up and is forced through different layers of membranes that help to purify it.

Use of large and small scale air filters can purify the air around us. These absorb dust, smoke and particulate matter from the air and give out fresh air. Large scale air filters have been installed in a few cities of China to tackle the problem of rising smog.⁸ These city scale air filters are high towers— up to 100 meters tall that have the capacity to purify the quality of air over an area of 10 square kilometers in the city. Since installation, each tower has produced about 10 million cubic meters of purified air per day. Records show that the average reduction in PM 2.5 (small pollution particles which penetrate deep into the respiratory system and cause the most damage to the body), fell 15 per cent.⁹

In Delhi, India, a small scale air purifying tower (40 feet tall) was installed with a capacity of cleaning air within 3km of radius around it. A single tower of s this scale costs about \$10,000.

Similar to this, there are cities like Rotterdam, which have come up with city-scale air purifiers that absorb pollutants and smog from the air and convert it to jewelry.¹⁰

This technology can be further developed and used in other cities and urban areas where the quality of air is needs improvement.



An example of a large scale air purifying plant installed at the terrace level in the industry. It absorbs carbon from the gas produced after combustion. The captured carbon is collected and is reused to make inks and paints.

Another part of Phase Two of our strategic plan focuses on replenishing environmental systems to pre-industrial levels. This is achieved by the creation of tree plantations at a scale that has a global impact. Trees are natural purifiers of air that can absorb about 48 pounds of carbon dioxide per year and can sequester a ton of carbon dioxide by the time it becomes 50 years old.¹¹

Tree Plantations

Our strategy calls for harnessing the interests, energy and enthusiasm of youth in schools and colleges to promote the plantation of trees. Every student will plant one tree, once a year as a part of their curriculum. The cost for one tree is as low as 10 cents. This and other associated costs of this program will be provided by the school's community.

The number of students in the world is about 1.29 billion for schools only.¹² Given this number, and the planting of just one tree each year by every student, it is possible to replenish the greenery in the environment over the course of a few years. Recently, Ethiopia set the world record for planting 350 million trees in 12 hours.¹³ The country has a goal to regain the lost forest area from their land which dropped from 30% to 4%.¹⁴

Funding for mass-tree planting can be promoted at city, state and country levels in different parts of the world. Tree planting competitions between schools, cities, states and countries can bolster the awareness, interest and fun of this initiative.

Implementation

Scale

The strategic initiatives presented above will be able to be scaled up differently in different countries according to the current situation that they are in. All of the solutions will be implemented on a global scale to make a real difference in the amount of carbon produced and removed from the atmosphere.

Costs

Giant Air Purifying Towers for large cities. The current models in use in China cost \$2 million per plant.¹⁵

Given their impact, it is estimated we will need 1,000 (at a cost of \$2 million) each year for 10 years to make the kind of impact our

Preferred State calls for. This is a small fraction of the damage the current air pollution causes to human health, economic productivity, and environmental sustainability. *Total cost per year: \$2 billion; total cost over 10 years: \$20 billion. Total area cleaned: 100,000 sq. kms. of the highest human population densities and highest human harm from air pollution in world (cities).*

Small Scale Air Purifiers for public squares and small areas. Each of these air purifiers costs \$10,000.¹⁶ It is estimated we will need 10,000 or these (at a cost of \$100 million) each year for ten years. *Total cost per year: \$100 million; total cost over 10 years: \$1 billion.*

Trees for Mass Plantings and reforestations of areas near schools and cities. At \$0.10 per tree and 1.29 billion students in the world, it will cost \$129 million for one tree per student per year to remove over 28 million tons of carbon per year. After five years, this will be approximately 140 million tons per year.¹⁷

Carbon Capture Membranes for industrial exhaust into the atmosphere. The current costs of these membranes is between \$20 to \$60 per ton of carbon removed. To remove 10 million tons of air polluting carbon from industrial processes will cost approximately \$200 to \$600 million. Amortized over ten years this will be \$20 to \$60 million per year.

Carbon Capture Plant: \$100 per ton of carbon for use in cities to reduce heavy polluted areas. With a price on carbon of \$100 or more per ton, these plants are a bargain.

First Steps/Next Year

New regulations and incentives are needed to boost this strategy into high gear. A global carbon tax of \$100 per ton will curtail fossil fuel use and spur investments to make much of the above a reality. Penalties, and their aggressive enforcement, for atmospheric pollution will be another big help. Tax incentives for investment into green energy and increased funding for school based tree-plantings will get that initiative moving quickly.

Removing all subsidies to fossil fuels will have an enormous impact on moving society away from carbon-intensive fuels.

Providing large-scale funding for green energy research to universities and tax incentives to companies for development of green energy technology will be a huge accelerant.

ENDNOTES

PART I: FOOD & WATER FOR ALL

Strategic Area I: Increasing Food Production/ Decreasing Loss

- 14 Assuming 3.2 billion people live in urban environments and each produce one pound of organic waste/day.
- 15 The Fertilizer Institute <http://www.tfi.org/Statistics/worldfertuse.asp>
- 16 <http://www.jepsonprairieorganics.com/compostprocess.htm>
- 17 http://www.japanfs.org/db/database.cgi?cmd=dp&num=1175&dp=data_e.html
- 18 http://www.japanfs.org/db/database.cgi?cmd=dp&num=1076&dp=data_e.html

Strategic Area II: Water Management

- 24 “Waterment” is a contraction of government water management and as such refers to the strategy of government-led initiatives to provide the basic human right to water to all citizens.
- 25 FAO, Water and Food Security (Rome, Food, and Agriculture Organization of the UN, 2002) www.fao.org
- 26 Developed in Kisii, Kenya, by a Dutch NGO.
- 27 UN FAO, AQUASTAT <http://www.fao.org/waicent/faoinfo/agricult/agl/aglw/aquastatweb/main/html/background.htm>
- 28 FAO, Water, and Food Security (Rome, Food and Agriculture Organization of the UN, 2002) www.fao.org

Strategic Area III: Governance

- 37 *Price of Peace Chart: Programs and Their Costs*, <http://www.bigpicturesmallworld.com/war-peace/programcosts.shtml>.

References

- <https://www.intechopen.com/books/recent-advances-in-carbon-capture-and-storage/membrane-separation-technology-in-carbon-capture>
- <https://newscenter.lbl.gov/2016/03/17/carbon-capture-membrane/>
- <https://www.azom.com/article.aspx?ArticleID=12014>
- <http://news.mit.edu/2019/greener-efficient-natural-gas-filtration-0409>
- <https://hub.globalccsinstitute.com/publications/global-status-ccs-2014/74-carbon-capture-cost>
- <https://www.cnbc.com/2019/06/21/carbon-engineering-co2-capture-backed-by-bill-gates-oil-companies.html>
- <https://www.power-technology.com/features/tidal-energy-advantages-and-disadvantages/>
- <https://www.scmp.com/news/china/society/article/2128355/china-builds-worlds-biggest-air-purifier-and-it-seems-be-working>

PART III

SUMMARY / SYNERGY

UN Photo/Fred Noy

SUMMARY/SYNERGY

The whole is more than the sum of its parts.

This book documents the explorations of many young people as they sought to understand our world and to figure out and design ways of making it work better for everyone. What is missing from the individual chapters or strategies are the interactions and resulting synergies of these parts as they combine into a whole that is exciting in its possibilities.

The preceding chapters describe a progression of technology, programs, policies and actions that, if implemented, transform the world as we know it to a world as we want it. Taken individually, each strategy can stand alone in making a significant contribution to improving some aspect of the human condition. Each strategy has links, interactions and impacts on the other strategies. Taken collectively, the strategies are more than the sum of their parts. They would, if implemented together, have a profound impact on our collective wealth, health, and potential. They would not only result in meeting the Sustainable Development Goals, but also go beyond them and transform the world in even more profound ways.

These strategies for transforming the world are suffused with a sense of values and vision that is bold, inclusive and caring—and which is for the entire world, not just a part of it. In some cases, the strategies are revolutionary and transformative, in others, “merely” dealing with critical problems. Taken together, all the strategies add up to a synergetic whole that is revolutionary, transformative and regenerative.

The whole, the parts and the interactions of the parts, creates a world where the most egregious forms of brutal poverty are eliminated, hunger and malnutrition eradicated, health, longevity and the quality of life are improved and the environment is allowed to regenerate. Where, in short, basic human needs are met, basic human rights fulfilled, and our environmental life-support systems are strengthened.

The global and local strategies described in this book help illustrate the creativity, values, vision, and commitment of the youth and concerned citizens of the world. They also represent what an

interdisciplinary, multigenerational group of non-experts can do when provided an opportunity and methodology for tackling the critical and complex problems facing the world.

Your feedback is most welcome—as is your ongoing participation in this evolving work. One way to do this is to send us your comments and suggestions by emailing us at info@designsciencelab.com. Those wishing to take part in upcoming Labs are urged to contact BigPictureSmallWorld at www.bigpicturesmallworld.com, or check in at www.designsciencelab.com.



Participants of the 2016 Global Solutions Lab presenting to the United Nations at the conclusion of the Lab.

APPENDIX 1: THE UN MILLENNIUM DEVELOPMENT GOALS

By 2015:

Goal #1: Eradicate extreme poverty and hunger

- Reduce by half the proportion of people living on less than a dollar a day.
- Reduce by half the proportion of people who suffer from hunger.

Goal #2: Achieve universal primary education

- Ensure that all boys and girls complete a full course of primary schooling.

Goal #3: Promote gender equality and empower women

- Eliminate gender disparity in primary and secondary education preferably by 2005, and at all levels by 2015.

Goal #4: Reduce child mortality

- Reduce by two thirds the mortality rate among children under five.

Goal #5: Improve maternal health

- Reduce by three quarters the maternal mortality ratio.

Goal #6: Combat HIV/AIDS, malaria and other diseases

- Halt and begin to reverse the spread of HIV/AIDS.
- Halt and begin to reverse the incidence of malaria and other major diseases.

Goal #7: Ensure environmental sustainability

- Integrate the principles of sustainable development into country policies and programmes; reverse loss of environmental resources.
- Reduce by half the proportion of people without sustainable access to safe drinking water.
- Achieve significant improvement in lives of at least 100 million slum dwellers, by 2020.

Goal #8: Develop a global partnership for development

- Develop further an open trading and financial system that is rule-

based, predictable and non-discriminatory. Includes a commitment to good governance, development and poverty reduction—nationally and internationally.

- Address the least developed countries' special needs. This includes tariff- and quota-free access for their exports; enhanced debt relief for heavily indebted poor countries; cancellation of official bilateral debt; and more generous official development assistance for countries committed to poverty reduction.
- Address the special needs of landlocked and small island developing States.
- Deal comprehensively with developing countries' debt problems through national and international measures to make debt sustainable in the long term.
- In cooperation with the developing countries, develop decent and productive work for youth.
- In cooperation with pharmaceutical companies, provide access to affordable essential drugs in developing countries.
- In cooperation with the private sector, make available the benefits of new technologies—especially information and communications technologies.

SUSTAINABLE DEVELOPMENT GOALS



APPENDIX 2: THE UN SUSTAINABLE DEVELOPMENT GOALS

By 2030:

- Goal 1** End poverty in all its forms everywhere
- Goal 2** End hunger, achieve food security and improved nutrition and promote sustainable agriculture
- Goal 3** Ensure healthy lives and promote well-being for all at all ages
- Goal 4** Ensure inclusive and equitable quality education and promote lifelong learning opportunities for all
- Goal 5** Achieve gender equality and empower all women and girls
- Goal 6** Ensure availability and sustainable management of water and sanitation for all
- Goal 7** Ensure access to affordable, reliable, sustainable and modern energy for all
- Goal 8** Promote sustained, inclusive and sustainable economic growth, full and productive employment and decent work for all
- Goal 9** Build resilient infrastructure, promote inclusive and sustainable industrialization and foster innovation
- Goal 10** Reduce inequality within and among countries
- Goal 11** Make cities and human settlements inclusive, safe, resilient and sustainable
- Goal 12** Ensure sustainable consumption and production patterns
- Goal 13** Take urgent action to combat climate change and its impacts
- Goal 14** Conserve and sustainably use the oceans, seas and marine resources for sustainable development
- Goal 15** Protect, restore and promote sustainable use of terrestrial ecosystems, sustainably manage forests, combat desertification, and halt and reverse land degradation and halt biodiversity loss
- Goal 16** Promote peaceful and inclusive societies for sustainable development, provide access to justice for all and build effective, accountable and inclusive institutions at all levels
- Goal 17** Strengthen the means of implementation and revitalize the Global Partnership for Sustainable Development

For more information:

http://www.un.org/ga/search/view_doc.asp?symbol=A/RES/70/1&Lang=E







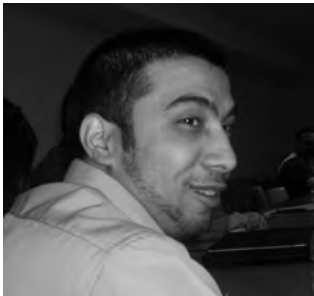
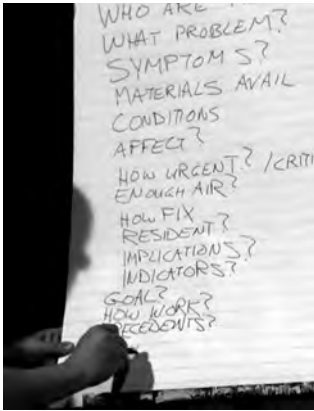

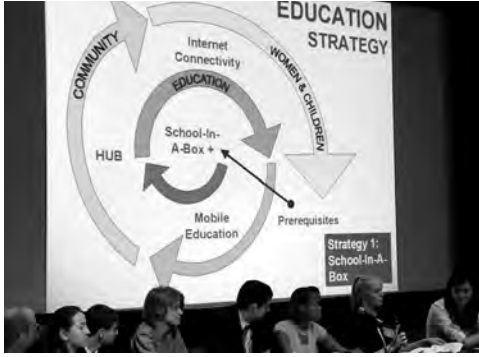





2005—The first Design Science Lab



2006 Lab



2007 Lab



2008 Lab



2009 Lab



2010 Lab



2011 Lab



2011 High School Lab



2012 Lab



2014 Lab



2014 Lab



2016 Lab



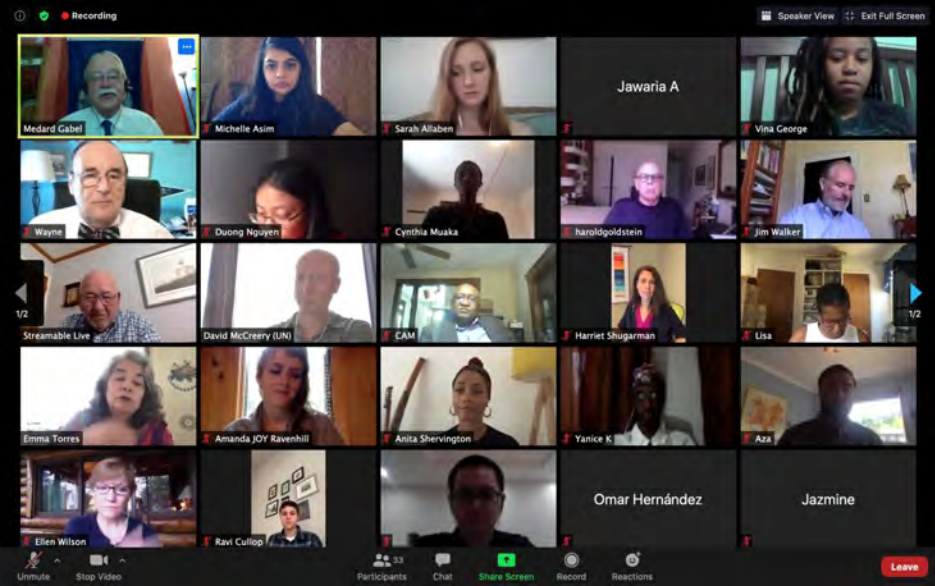

2020, with the COVID-19 pandemic, brought the first virtual lab. It had the added benefit of being more accessible to participants around the globe, without the impediment of physically crossing borders.



ABOUT MEDARD GABEL

Medard Gabel is the executive director of EarthGame. He is the author or editor of six previous books on the global energy situation (*Energy, Earth and Everyone*, Anchor Press/Doubleday); the global food situation (*Ho-Ping: Food for Everyone*, Anchor Press/Doubleday); the U.S. food situation (*Empty Breadbasket*, Rodale Press), multi-national corporations (*Global Inc.: An Atlas of the Multinational Corporation*, The New Press), strategic planning (*Design Science Primer*), climate change, and (*Climate Change—Take Action Now*, UNICEF). He is currently working on *Ten Billion Billionaires* that deals with global predicaments and prospects.

He worked with Buckminster Fuller for over 12 years and has been a consultant to UNEP, UNITAR, the U.S. State Department, Department of Agriculture, USAID, and the Governor's Energy Council of Pennsylvania, as well as Motorola, IBM, General Motors, Novartis, Chase Manhattan Bank and numerous other multinational corporations. The Global Solutions Lab is the integration of all he has learned from all his teachers, especially those listed in this book.

ABOUT GEM & WAYNE JACOBY

Global Education Motivators (GEM) is dedicated to meeting the complex needs of bringing the world into the classroom. It has worked with students, teachers and administrators through on-site and distance learning workshops and classroom program support to promote a better understanding of the world and its people. Being convinced that international communication exchange is a key to future world peace, GEM delivers cross-cultural perspectives as an integral part of its unique global learning programs. An integral part of GEM's mission is to support the work and mission of the United Nations and the important role of civil society in today's world. It is convinced that global awareness is closely tied to global responsibility. GEM is located at Chestnut Hill College in Philadelphia, Pennsylvania, and was co-founded by Wayne Jacoby.

“How do we make the world work for 100% of humanity in the shortest possible time, through spontaneous cooperation, without ecological offense or the disadvantage of anyone?”

—Buckminster Fuller

This report, on the work of the 2005–2019 Global Solutions Labs held at the United Nations, UN International School, and Chestnut Hill College, reveals what happens when solid methodology meets creative minds. Over the past 15 years, hundreds of people, most aged 18 to 26 (but a few as young as 55), have come together to look at the issues of hunger, poverty, education, health care, energy, water, women’s rights, employment, the environment and other topics to find ways to make the world work for 100% of humanity in the shortest possible time. We offer these creative solutions to you in this book.

—Medard Gabel